

Electronic housing - ME 22,5 OT-3MSTBO GN - 2735962

Please be informed that the data shown in this PDF Document is generated from our Online Catalog. Please find the complete data in the user's documentation. Our General Terms of Use for Downloads are valid (<http://download.phoenixcontact.com>)



Upper part of housing, for COMBICON connection, three-level

Product Features

- Tool-free mounting
- ME...TBUS connector with 5 parallel contacts can be snapped onto DIN rails to save space
- Low design width with a high number of positions
- Gold contacts for data transmission and power supply (125 V, 8 A)
- Large assembly area
- When a device is unplugged from the system as a whole, the signal chain is not interrupted# Supply via standard MINI COMBICON plug
- Recessed labeling areas
- Same PCB geometry for all design widths
- Fast mounting on DIN rails according to EN 60715
- Inflammability class V0 according to UL 94
- Cost savings thanks to easy device production
- Material and part identification embossed on the housing (recyclability)
- Electronic components can be partially removed
- Functional earth ground contact (EMC) integrated in the housing base
- Optional BUS connection integrated in the housing, for either parallel or serial contacting
- Metal foot catch

Key commercial data

package_quantity	10
GTIN	4017918899387

Technical data

General

Housing type	Upper part
Housing material	Polyamide
Color	green

Ambient conditions

Ambient temperature (operation)	-40 °C ... 105 °C
--	-------------------

Dimensions

Constructional height	51.5 mm
------------------------------	---------

Electronic housing - ME 22,5 OT-3MSTBO GN - 2735962

Technical data

Dimensions

Width	22.5 mm
--------------	---------

Technical data

Inflammability class according to UL 94	V0
Number of positions	24

classifications

eCl@ss

eCl@ss 4.0	27180401
eCl@ss 4.1	27180401
eCl@ss 5.0	27180506
eCl@ss 5.1	27180506
eCl@ss 6.0	27180802
eCl@ss 7.0	27182702
eCl@ss 8.0	27182702

ETIM

ETIM 2.0	EC001031
ETIM 3.0	EC001031
ETIM 4.0	EC001031
ETIM 5.0	EC000886

UNSPSC

UNSPSC 6.01	31261501
UNSPSC 7.0901	31261501
UNSPSC 11	31261501
UNSPSC 12.01	31261501
UNSPSC 13.2	31261501

approvals

UL Recognized /

Approval details

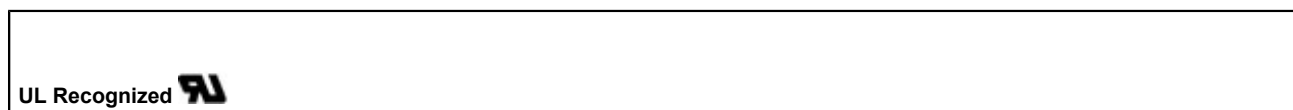

Drawings

Electronic housing - ME 22,5 OT-3MSTBO GN - 2735962

Dimensioned drawing

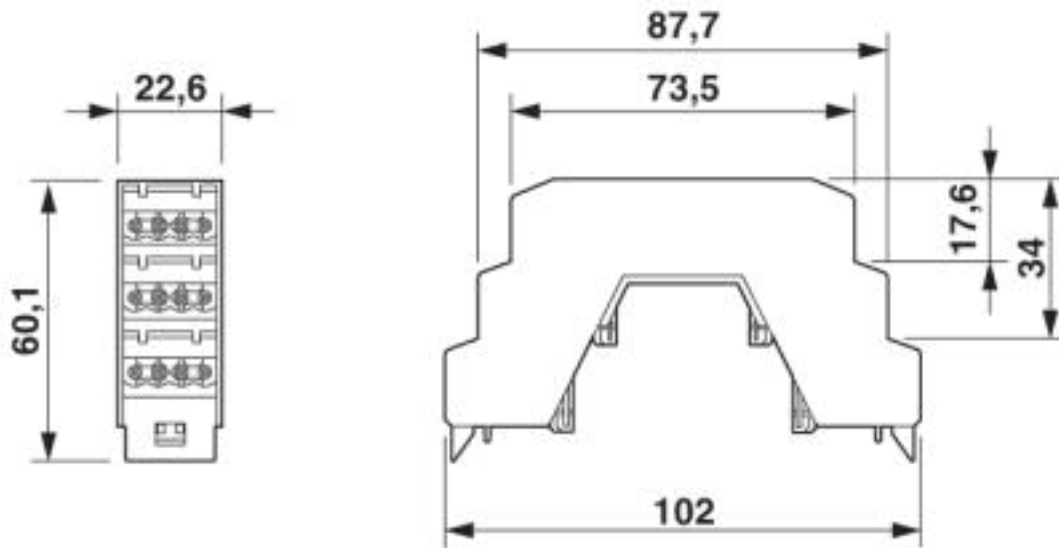

© Phoenix Contact 2013 - all rights reserved
<http://www.phoenixcontact.com>