

Electronic housing - UEGM 25-FS/FS - 2792086

Please be informed that the data shown in this PDF Document is generated from our Online Catalog. Please find the complete data in the user's documentation. Our General Terms of Use for Downloads are valid (<http://download.phoenixcontact.com>)



Electronic housing, for PCB insertion, fully equipped with 3 screw or 6 tab connections per side

The illustration shows version UEGM 22,5-FS/FS

Product Features

- Cost-effective series production, since the base element and the assembled PCB are soldered by machine
- Can be snapped onto standard NS 35/7,5 and NS 35/15 DIN rails
- Efficient assembly thanks to overlapping housing parts
- Complex electronic circuits can be integrated, with up to 24 connections on two levels

Key commercial data

package_quantity	10
GTIN	4017918072551

Technical data

General

Housing type	Complete housing
Housing material	Polyamide (PA 6.6)
Color	green

Ambient conditions

Ambient temperature (operation)	-40 °C ... 105 °C
--	-------------------

Dimensions

Length	101 mm
Constructional height	85.5 mm
Width	25 mm

Technical data

Inflammability class according to UL 94	V0
Power dissipation at 20°C in the horizontal mounting position	4 W 10 W
Number of positions	12

Connection data

Conductor cross section solid min.	0.2 mm ²
Conductor cross section solid max.	4 mm ²

Electronic housing - UEGM 25-FS/FS - 2792086

Technical data

Connection data

Conductor cross section stranded min.	0.2 mm ²
Conductor cross section stranded max.	2.5 mm ²
Conductor cross section AWG/kcmil min.	24
Conductor cross section AWG/kcmil max	12

classifications

eCl@ss

eCl@ss 4.0	27180401
eCl@ss 4.1	27180401
eCl@ss 5.0	27180506
eCl@ss 5.1	27180506
eCl@ss 6.0	27180802
eCl@ss 7.0	27182702
eCl@ss 8.0	27182702

ETIM

ETIM 2.0	EC001031
ETIM 3.0	EC001031
ETIM 4.0	EC001031
ETIM 5.0	EC001031

UNSPSC

UNSPSC 6.01	31261501
UNSPSC 7.0901	31261501
UNSPSC 11	31261501
UNSPSC 12.01	31261501
UNSPSC 13.2	31261501

approvals

UL Recognized / GOST / GOST /

Approval details



Electronic housing - UEGM 25-FS/FS - 2792086

approvals



accessories

PCB

P 1-UEGM - 2792109



Drawings

Explosion drawing

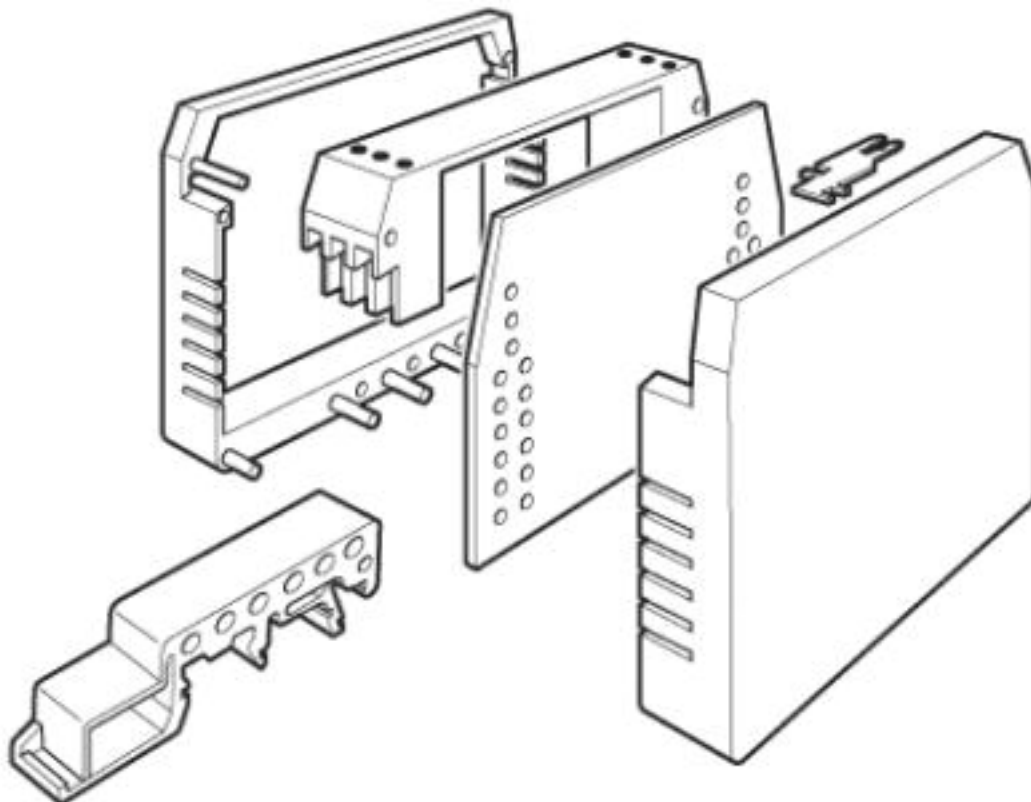

Electronic housing - UEGM 25-FS/FS - 2792086

Dimensioned drawing

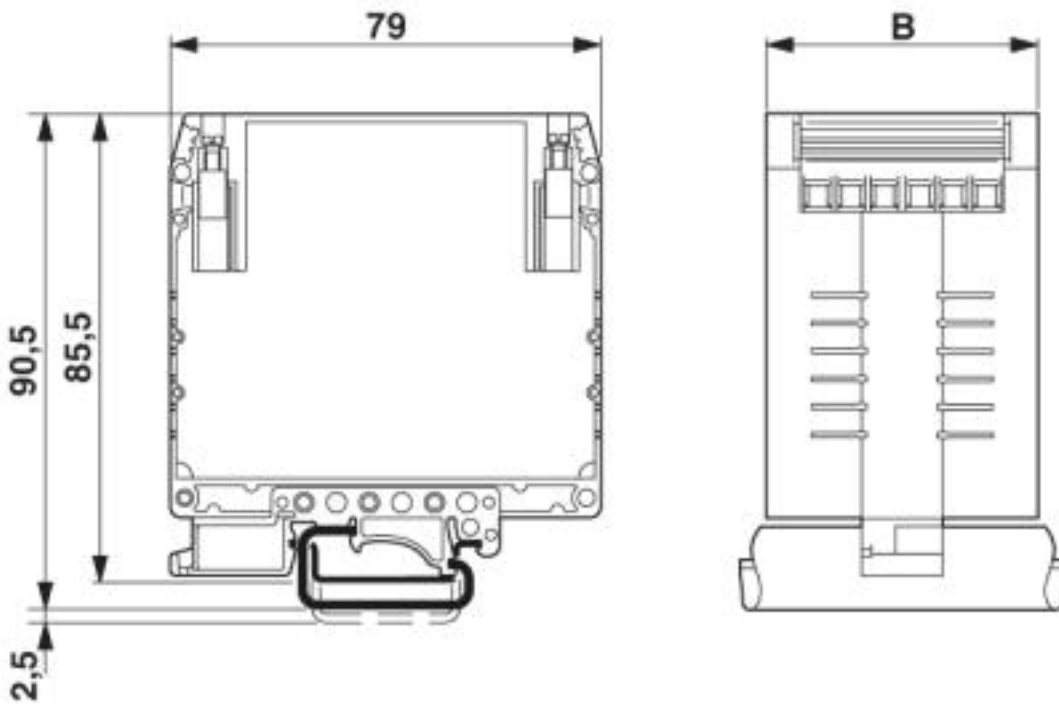

Electronic housing - UEGM 25-FS/FS - 2792086

Dimensioned drawing

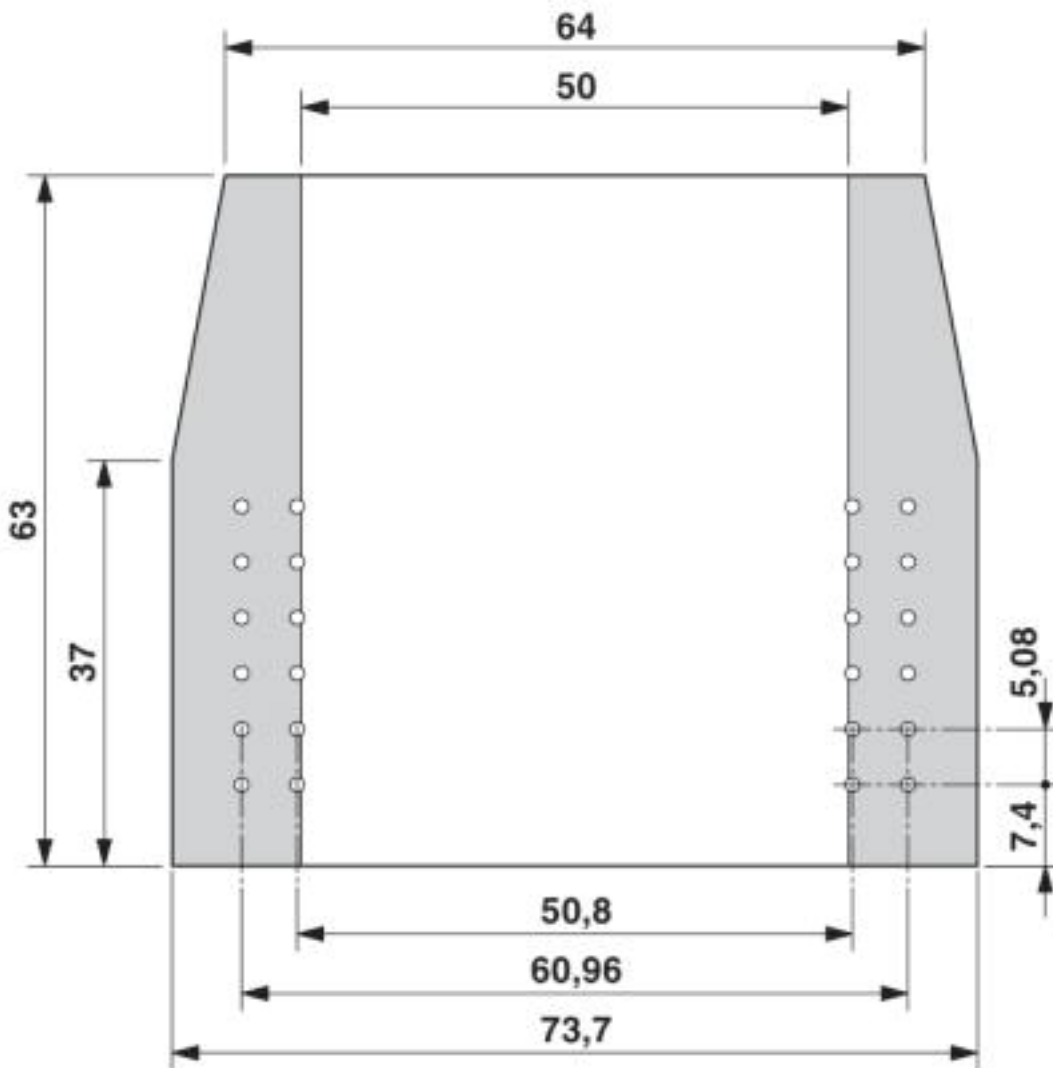

Electronic housing - UEGM 25-FS/FS - 2792086

Schematic diagram

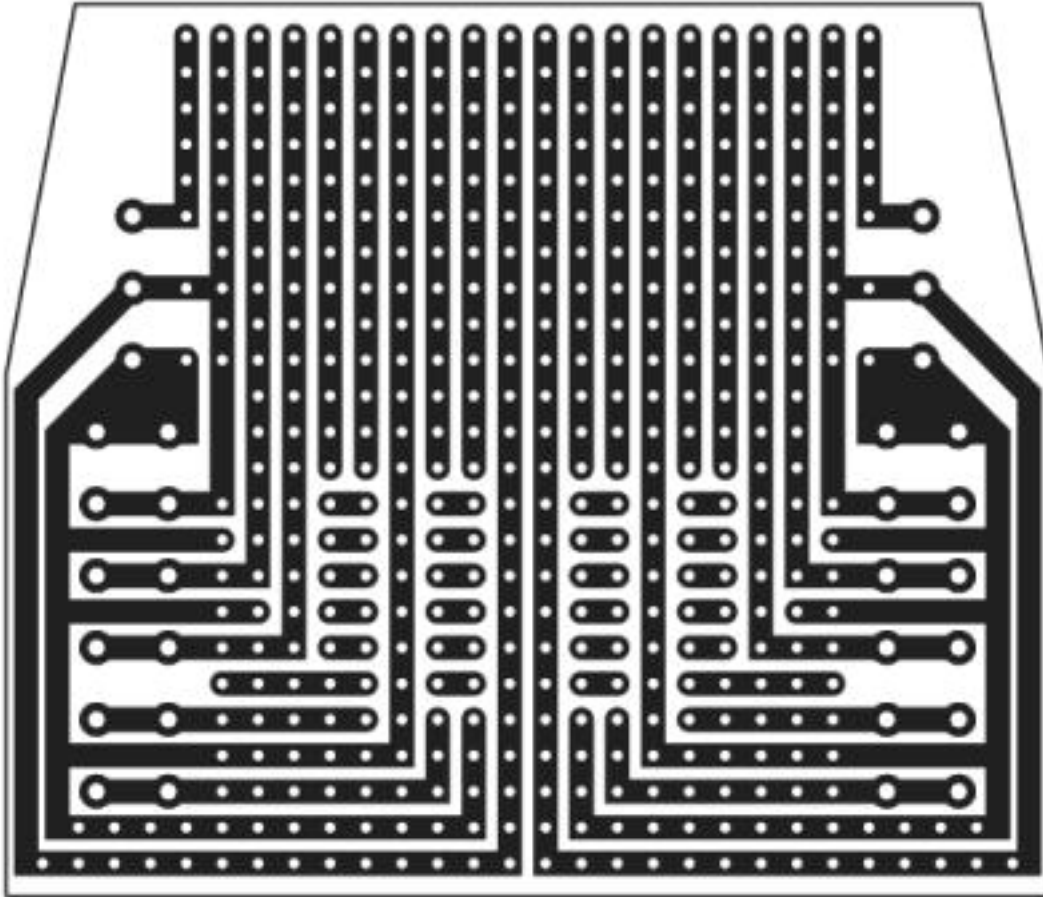

© Phoenix Contact 2013 - all rights reserved
<http://www.phoenixcontact.com>