

DATA SHEET

SURFACE-MOUNT CERAMIC MULTILAYER CAPACITORS

Class 2, Y5V

16/25/50 V



Surface-mount ceramic multilayer capacitors

Class 2, Y5V
16/25/50 V

FEATURES

- Five standard sizes
- High capacitance per unit volume
- Supplied in tape on reel
- NiSn terminations.

APPLICATIONS

- Consumer electronics, for example:
 - Tuners
 - Television receivers
 - Video recorders
 - All types of cameras
 - Mobile telephones.

DESCRIPTION

The capacitor consists of a rectangular block of ceramic dielectric in which a number of interleaved metal electrodes are contained. This structure gives rise to a high capacitance per unit volume.

The inner electrodes are connected to the two terminations and finally covered with a layer of plated tin (NiSn). A cross section of the structure is shown in Fig.1.

QUICK REFERENCE DATA

DESCRIPTION	VALUE
Rated voltage U_R (DC)	16 V, 25 V, 50 V
Capacitance range (E6 series)	10 nF to 10 μ F; note 1
Tolerance on capacitance	$\pm 20\%$ (M); -20% to $+80\%$ (Z)
Test voltage (DC) for 1 minute:	$2.5 \times U_R$
Sectional specifications	IEC 60384-10, second edition 1989-04
Detailed specification	based on IEC 60384-10-1
End terminations	NiSn
Climatic category (IEC 60068)	30/85/21

Note

1. Measured at 25 °C, 1 V and 1 kHz, using a four-gauge method.

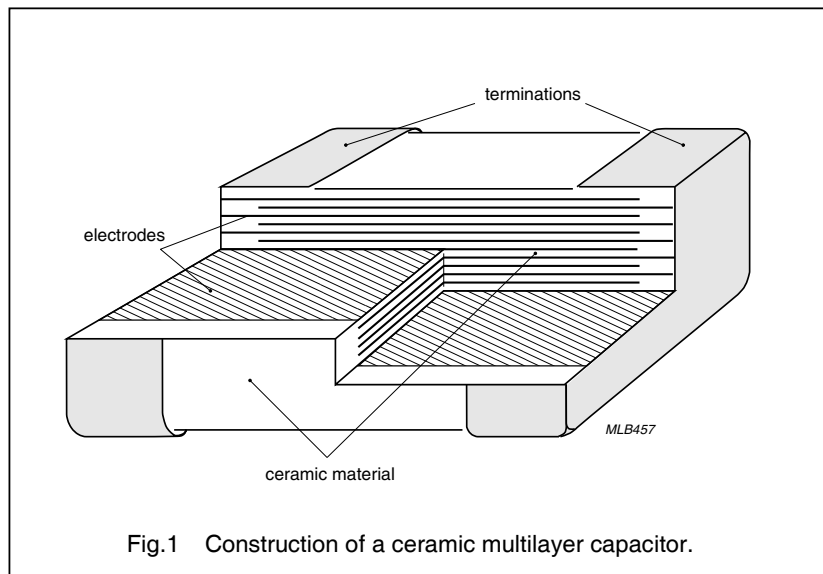

Surface-mount ceramic multilayer capacitors

Class 2, Y5V 16/25/50 V

MECHANICAL DATA

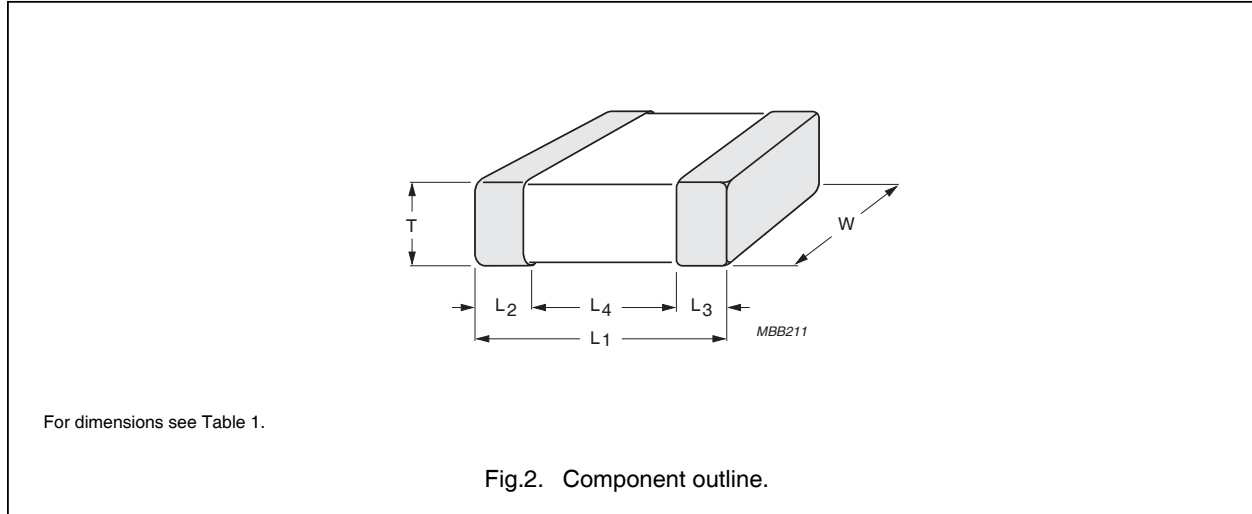

Physical dimensions

Table 1 Capacitor dimensions; see Fig.2

CASE SIZE	L ₁	W	T		L ₂ and L ₃		L ₄ MIN.
			MIN.	MAX.	MIN.	MAX.	
Dimensions in millimetres							
0402	1.0 ±0.05	0.5 ±0.05	0.45	0.55	0.15	0.30	0.40
0603	1.6 ±0.10	0.8 ±0.07	0.73	0.87	0.25	0.65	0.40
0805	2.0 ±0.10	1.25 ±0.10	0.50	1.35	0.25	0.75	0.55
1206	3.2 ±0.15	1.6 ±0.15	0.50	1.75	0.25	0.75	1.40
1210	3.2 ±0.20	2.5 ±0.20	1.40	1.60	0.25	0.75	1.40
Dimensions in inches							
0402	0.040 ±0.002	0.020 ±0.002	0.018	0.022	0.008	0.012	0.016
0603	0.063 ±0.004	0.032 ±0.003	0.029	0.035	0.010	0.026	0.016
0805	0.079 ±0.004	0.049 ±0.004	0.020	0.053	0.010	0.030	0.022
1206	0.126 ±0.006	0.063 ±0.006	0.020	0.069	0.010	0.030	0.056
1210	0.126 ±0.008	0.098 ±0.008	0.047	0.069	0.010	0.030	0.056

**Surface-mount ceramic
multilayer capacitors**
**Class 2, Y5V
16/25/50 V**

SELECTION CHART FOR 16 V AND 25 V

C (nF)	LAST TWO DIGITS OF 12NC	16 V					25 V			
		0402	0603	0805	1206	1210	0603	0805	1206	1210
1	23									
1.5	25									
2.2	27									
3.3	29									
4.7	32									
6.8	34									
10	36	0.5 ±0.05					0.8 ±0.07			
15	38									
22	41									
33	43									
47	45									
68	47									
100	49							0.6 ±0.1	0.6 ±0.1	
150	52		0.8 ±0.07				0.85 ±0.1			
220	54						1.25 ±0.1			
330	56									
470	58			0.85 ±0.1			0.85 ±0.1	0.85 ±0.1		
680	61									
1,000	63				0.85 ±0.1				1.15 ±0.1	
2,200	67				1.15 ±0.1				0.85 ±0.1	
4,700	72				0.85 ±0.1				0.85 ±0.1	
10,000	76				1.15 ±0.1	1.5 ±0.1			1.15 ±0.1	1.5 ±0.1

Note

1. Values in shaded cells indicate thickness class in mm.

Surface-mount ceramic multilayer capacitors

Class 2, Y5V 16/25/50 V

SELECTION CHART FOR 50 V

C (nF)	LAST TWO DIGITS OF 12NC	50 V		
		0603	0805	1206
10	05	0.8 ±0.07	0.6 ±0.1	
15	06			
22	07			
33	08			
47	09			
68	11			
100	12			0.6 ±0.1
150	13		0.85 ±0.1	
220	14			
330	15		1.25 ±0.1	
470	16			0.85 ±0.1
680	17			
1 000	18			1.15 ±0.1

Note

1. Values in shaded cells indicate thickness class in mm.

Thickness classification and packing quantities

THICKNESS CLASSIFICATION (mm)	8 mm TAPE WIDTH QUANTITY PER REEL				QUANTITY PER BULK CASE		
	Ø180 mm; 7"		Ø330 mm; 13"		0402	0603	0805
	PAPER	BLISTER	PAPER	BLISTER			
0.5 ±0.05	10 000	–	50 000	–	50 000	–	–
0.6 ±0.10	4 000	–	20 000	–	–	–	10 000
0.8 ±0.07	4 000	–	15 000	–	–	15 000	–
0.85 ±0.10	4 000	–	15 000	–	–	15 000	8 000
1.15 ±0.10	–	3 000	–	10 000	–	–	–
1.25 ±0.10	–	3 000	–	1 000	–	–	5 000
1.5 ±0.10	–	3 000	–	–	–	–	–

Surface-mount ceramic multilayer capacitors

Class 2, Y5V 16/25/50 V

ORDERING INFORMATION

Components may be ordered by using either a Phycomp's unique 12NC or simple 15-digit clear text code.

Ordering code 12NC (preferred)

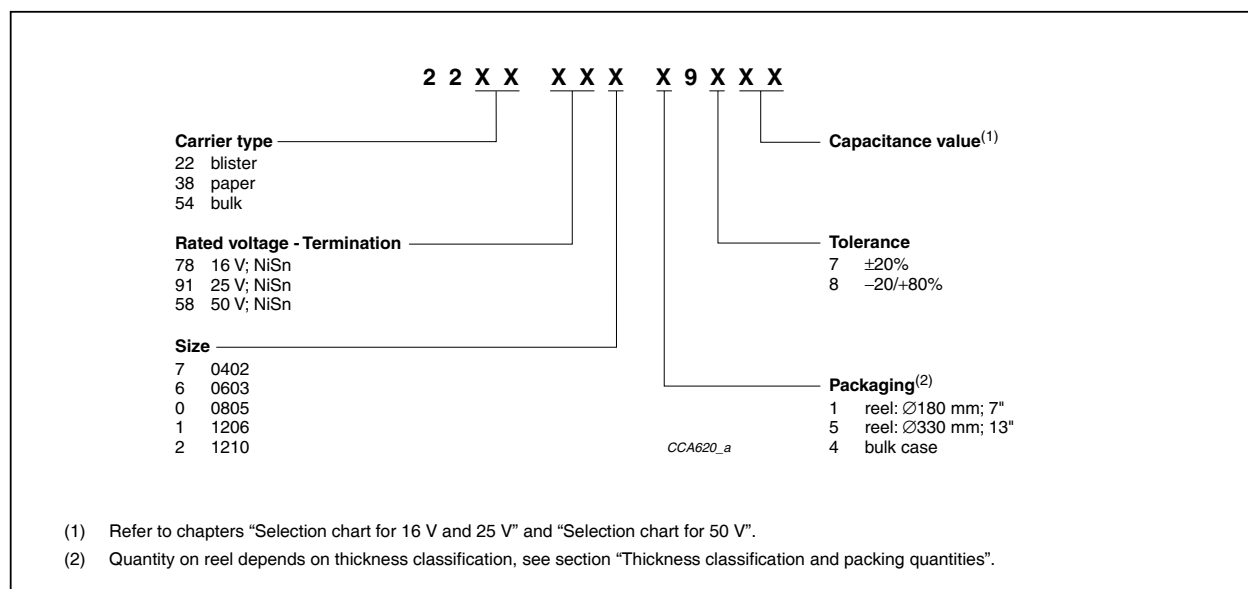

Phycomp Clear text code

EXAMPLE: 12062F105M8BB0D

Size Code	Temp. Char.	Capacitance	Tol.	Vol.	Termination	Packing	Marking	Series
0402 0603 0805 1206 1210	2F = Y5V	105 = 1000000 pF; the third digit signifies the multiplying factor: 2 = × 100 3 = × 1000 4 = × 10 000 5 = × 100 000 6 = × 1 000 000	M = ±20% Z = -20% / +80%	7 = 16 V 8 = 25 V 9 = 50 V	B = NiSn	2 = 180 mm; 7" paper 3 = 330 mm; 13" paper B = 180 mm; 7" blister F = 330 mm; 13" blister P = bulk case	0 = no marking	D = BME

Surface-mount ceramic multilayer capacitors

Class 2, Y5V 16/25/50 V

ELECTRICAL CHARACTERISTICS

Class 2 capacitors; Y5V dielectric; NiSn terminations

Unless otherwise stated all electrical values apply at an ambient temperature of 25 ± 1 °C, an atmospheric pressure of 86 to 105 kPa, and a relative humidity of 63 to 67%.

DESCRIPTION	VALUE
Capacitance range (E6 series); note 1	10 nF to 10 μ F
Tolerance on capacitance after 1000 hours	$\pm 20\%$ (M); -20% to $+80\%$ (Z)
Tan δ ; note 1: all 25 V and 50 V except 0805 \geq 330 nF; 0603 /100 nF; 1206 /1 μ F; 1210 /10 μ F sizes 0805 / 330 nF; 0603 / 100 nF; 1206 /1 F 25 V 0805 \geq 470 nF 1210 /10 μ F all 16 V except 0402; 0603 \geq 330 nF; 0805 \geq 1.5 μ F; 1206 \geq 3.3 μ F; 1210 /10 μ F sizes 0402; 0603 \geq 330 nF; 0805 \geq 1.5 μ F; 1206 \geq 3.3 μ F; 1210 /10 μ F	$\leq 5\%$ $\leq 7\%$ $\leq 9\%$ $\leq 12.5\%$ $\leq 9\%$ $\leq 12.5\%$
Insulation resistance after 1 minute at U_R (DC):	$R_{ins} > 10 \text{ G}\Omega$ or $R_{ins} \times C \geq 500$ seconds whichever is less
Maximum capacitance change with respect to capacitance at 25 °C (for typical values see Fig.5)	$+22\%$ to -82%
Ageing	typical 7% per time decade
Resistance to soldering heat	260 °C; 10 seconds

Note

1. Measured at 25 °C, 1 V, 1 kHz, using a four-gauge method.

Surface-mount ceramic multilayer capacitors

Class 2, Y5V
16/25/50 V

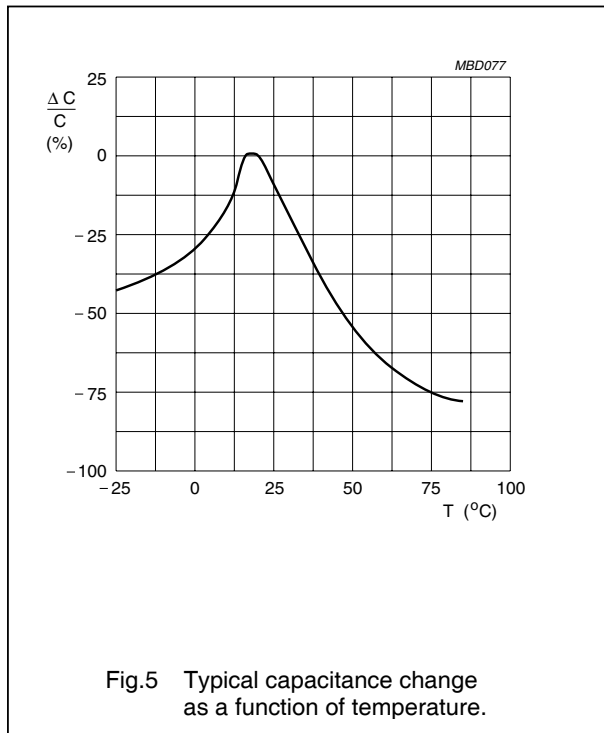
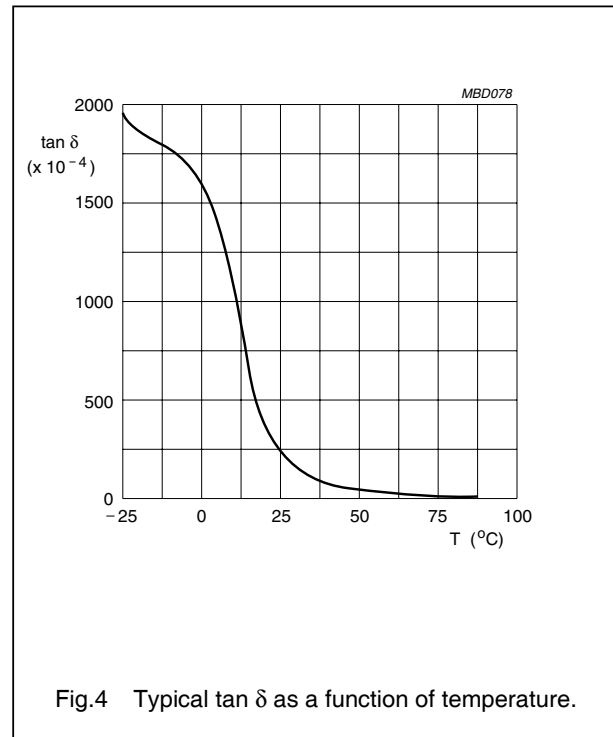
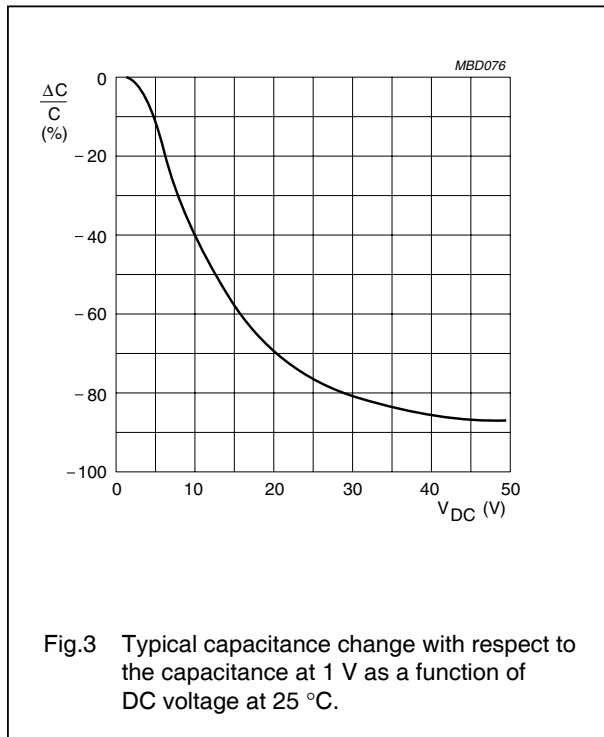

Surface-mount ceramic multilayer capacitors

Class 2, Y5V 16/25/50 V

TESTS AND REQUIREMENTS

Table 2 Test procedures and requirements

IEC 60384-10/ CECC 32 100 CLAUSE	IEC 60068-2 TEST METHOD	TEST	PROCEDURE	REQUIREMENTS
4.4		mounting	the capacitors may be mounted on printed-circuit boards or ceramic substrates by applying wave soldering, reflow soldering (including vapour phase soldering) or conductive adhesive	no visible damage
4.5		visual inspection and dimension check	any applicable method using $\times 10$ magnification	in accordance with specification
4.6.1		capacitance	$f = 1 \text{ kHz}$; Y5V measuring voltage $1 V_{\text{rms}}$ at $25 \text{ }^\circ\text{C}$	within specified tolerance
4.6.2		$\tan \delta$	$f = 1 \text{ kHz}$; Y5V measuring voltage $1 V_{\text{rms}}$ at $25 \text{ }^\circ\text{C}$	in accordance with specification
4.6.3		insulation resistance	at U_R (DC) for 1 minute	$R_i C_R \geq 500 \text{ s}$
4.6.4		voltage proof	$2.5 \times U_R$ for 1 minute	no breakdown or flashover
4.7.1		temperature coefficient	between minimum and maximum temperature	in accordance with specification
4.8		adhesion	a force of 5 N applied for 10 s to the line joining the terminations and in a plane parallel to the substrate	no visible damage
4.9		bond strength of plating on end face	mounted in accordance with IEC 60384-1, paragraph 4.35	no visible damage
			conditions: bending 1 mm at a rate of 1 mm/s, radius jig 340 mm	$\Delta C/C: \leq 30\%$
4.10	Tb	resistance to soldering heat	preconditioning: 120 to 150 $^\circ\text{C}$ during 1 minute; 260 $\pm 5 \text{ }^\circ\text{C}$ for 10 $\pm 0.5 \text{ s}$ in a static solder bath	the terminations shall be well tinned after recovery $\Delta C/C: \pm 20\%$ $\tan \delta$: original specification R_{ins} : original specification
		resistance to leaching	260 $\pm 5 \text{ }^\circ\text{C}$ for 30 $\pm 1 \text{ s}$ in a static solder bath	using visual enlargement of $\times 10$, dissolution of the terminations shall not exceed 10%

**Surface-mount ceramic
multilayer capacitors**
**Class 2, Y5V
16/25/50 V**

IEC 60384-10/ CECC 32 100 CLAUSE	IEC 60068-2 TEST METHOD	TEST	PROCEDURE	REQUIREMENTS
4.11	Ta	solderability	zero hour test, and test after storage (20 to 24 months) in original packing in normal atmosphere; unmounted chips completely immersed for 2 ± 0.5 s in a solder bath at 235 ± 5 °C	the terminations shall be well tinned
4.12	Na	rapid change of temperature	preconditioning: between minimum and maximum temperature, 5 cycles	no visible damage after 48 hours recovery: $\Delta^\circ\text{C}/\text{C}: \leq \pm 20\%$
4.14	Ca	damp heat, steady state	initialization: 48 \pm 4 hours after U_R at 40 °C for 1 hour (for initial value measurement); 500 \pm 12 hours at 40 °C; 90 to 95% RH; U_R applied	no visible damage after 48 hours recovery: $\Delta^\circ\text{C}/\text{C}: +30\%/-40\%$ $\tan \delta: \leq 15\%$ $R_{\text{ins}}: 500 \text{ M}\Omega$ or $R_1 C_R \geq 100 \text{ s}$, whichever is less
		damp heat; with U_R load	initialization: 48 hours after U_R at 40 °C; for 1 hour (for initial value measurement); 500 \pm 12 hours at 40 °C; 90 to 95% RH; U_R applied	preconditioning: U_R at 40 °C for 1 hour, after 48 hours recovery: $\Delta^\circ\text{C}/\text{C}: +30\%/-40\%$ $\tan \delta: \leq 15\%$ $R_{\text{ins}}: 500 \text{ M}\Omega$ or $R_1 C_R \geq 25 \text{ s}$, whichever is less
4.15		endurance	initialization: $2 \times U_R$ at 85 °C for 1 hour, (initial value measurement after 48 \pm 4 hours); $2 \times U_R$ at 85 °C for 1000 hours recovery 48 \pm 4 hours at room temperature	after 48 hours recovery: $\Delta^\circ\text{C}/\text{C}: +30\%/-40\%$ $\tan \delta: \leq 15\%$ $R_{\text{ins}}: 1000 \text{ M}\Omega$ or $R_1 C_R \geq 50 \text{ s}$, whichever is less

**Surface-mount ceramic
multilayer capacitors****Class 2, Y5V
16/25/50 V****REVISION HISTORY**

Revision	Date	Change Notification	Description
Rev 10	2005 Sep 21	–	Y5V 0805 16 V thickness revised and range extended from 2.2 μ F to 4.7 μ F
Rev.9	2005 June 24	–	- Revised thickness of: <ul style="list-style-type: none">• Y5V 1206 16 V from 4.7 μF to 10 μF• Y5V1206 25 V from 2.2 μF to 10 μF
Rev.8	2005 Jan 13	–	- Revised thickness of Y5V 0805 16 V 1 μ F and Y5V 0805 25 V 470 nF to 1 μ F
Rev.7	2003 Jul 08	–	- Updated company logo