

Electronic housing - UM122-PROFIL 100CM - 2914576

Please be informed that the data shown in this PDF Document is generated from our Online Catalog. Please find the complete data in the user's documentation. Our General Terms of Use for Downloads are valid (<http://download.phoenixcontact.com>)

Profile panel mounting base, with a design width of 122 mm and a fixed length of 100 cm



Product Features

- Flexible size and shape
- Inexpensive as a result of reducing the number of separate housing parts
- Wide range of options for external conductor connection
- High degree of mechanical stability by screwing the lateral elements to the profile
- Can be snapped onto standard NS 35/7,5 and NS 35/15 DIN rails

Key commercial data

package_quantity	1
GTIN	4017918959166

Technical data

General

Housing type	Panel mounting base
Housing material	PVC
Color	green

Ambient conditions

Ambient temperature (operation)	-15 °C ... 50 °C
--	------------------

Dimensions

Length	1 m
Width	1000 mm

Technical data

Inflammability class according to UL 94	V0
--	----

classifications

eCl@ss

eCl@ss 4.0	27180401
eCl@ss 4.1	27180401
eCl@ss 5.0	27180506

Electronic housing - UM122-PROFIL 100CM - 2914576

classifications

eCl@ss

eCl@ss 5.1	27180506
eCl@ss 6.0	27180802
eCl@ss 7.0	27182701
eCl@ss 8.0	27182701

ETIM

ETIM 2.0	EC001031
ETIM 3.0	EC001031
ETIM 4.0	EC001031
ETIM 5.0	EC000721

UNSPSC

UNSPSC 6.01	31261501
UNSPSC 7.0901	31261501
UNSPSC 11	31261501
UNSPSC 12.01	31261501
UNSPSC 13.2	31261501

Drawings

Dimensioned drawing

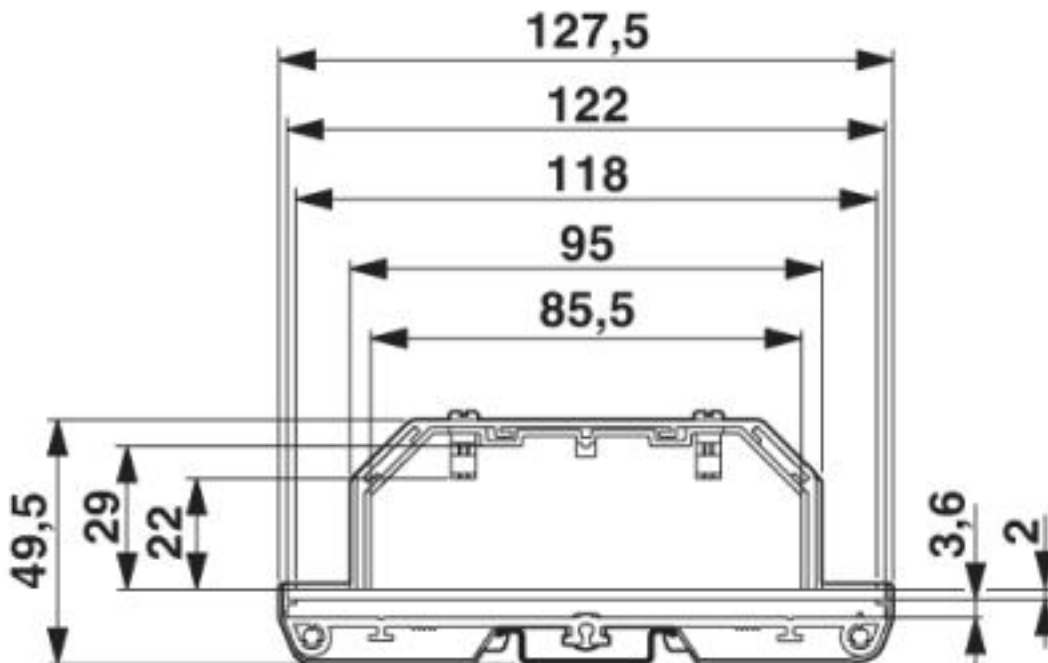

Electronic housing - UM122-PROFIL 100CM - 2914576

Dimensioned drawing

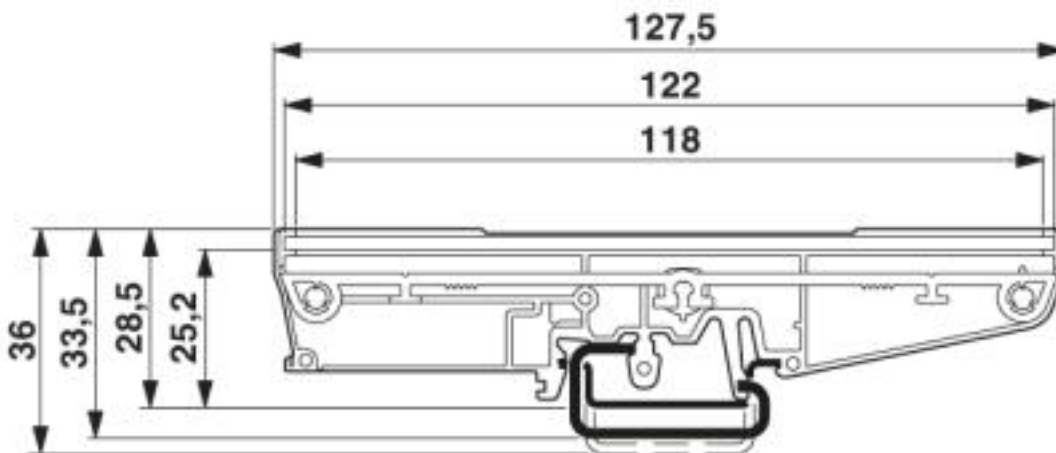

© Phoenix Contact 2013 - all rights reserved
<http://www.phoenixcontact.com>