

Electronic housing - EM-MP 45N - 2943712

Please be informed that the data shown in this PDF Document is generated from our Online Catalog. Please find the complete data in the user's documentation. Our General Terms of Use for Downloads are valid (<http://download.phoenixcontact.com>)



Mounting plate, for screwing on siz 0 switchgear

Key commercial data

package_quantity	10
GTIN	4017918081263

Technical data

General

Housing type	DIN rail adapter
Housing material	Polyamide fiber reinforced
Color	green

Ambient conditions

Ambient temperature (operation)	-40 °C ... 105 °C
--	-------------------

Dimensions

Length	68 mm
Width	45 mm

Technical data

Inflammability class according to UL 94	V2
--	----

classifications

eCl@ss

eCl@ss 4.0	27180401
eCl@ss 4.1	27180401
eCl@ss 5.0	27180506
eCl@ss 5.1	27180506
eCl@ss 6.0	27180802
eCl@ss 7.0	27379206
eCl@ss 8.0	27379206

ETIM

ETIM 2.0	EC001031
-----------------	----------

Electronic housing - EM-MP 45N - 2943712

classifications

ETIM

ETIM 3.0	EC001031
ETIM 4.0	EC001031
ETIM 5.0	EC001031

UNSPSC

UNSPSC 6.01	31261501
UNSPSC 7.0901	31261501
UNSPSC 11	31261501
UNSPSC 12.01	31261501
UNSPSC 13.2	31261501

Drawings

Dimensioned drawing

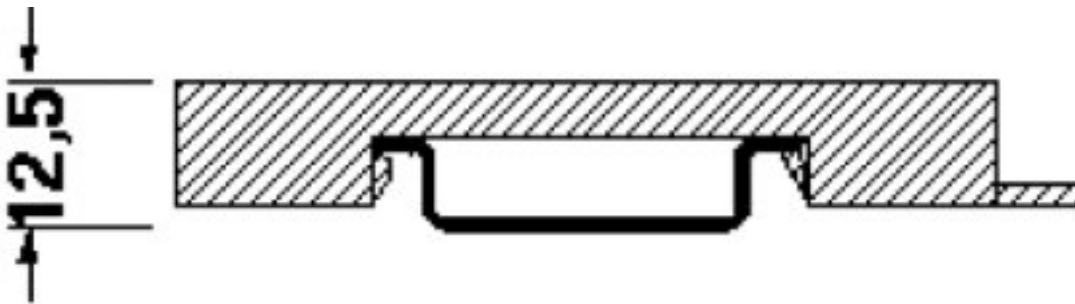

Electronic housing - EM-MP 45N - 2943712

Dimensioned drawing

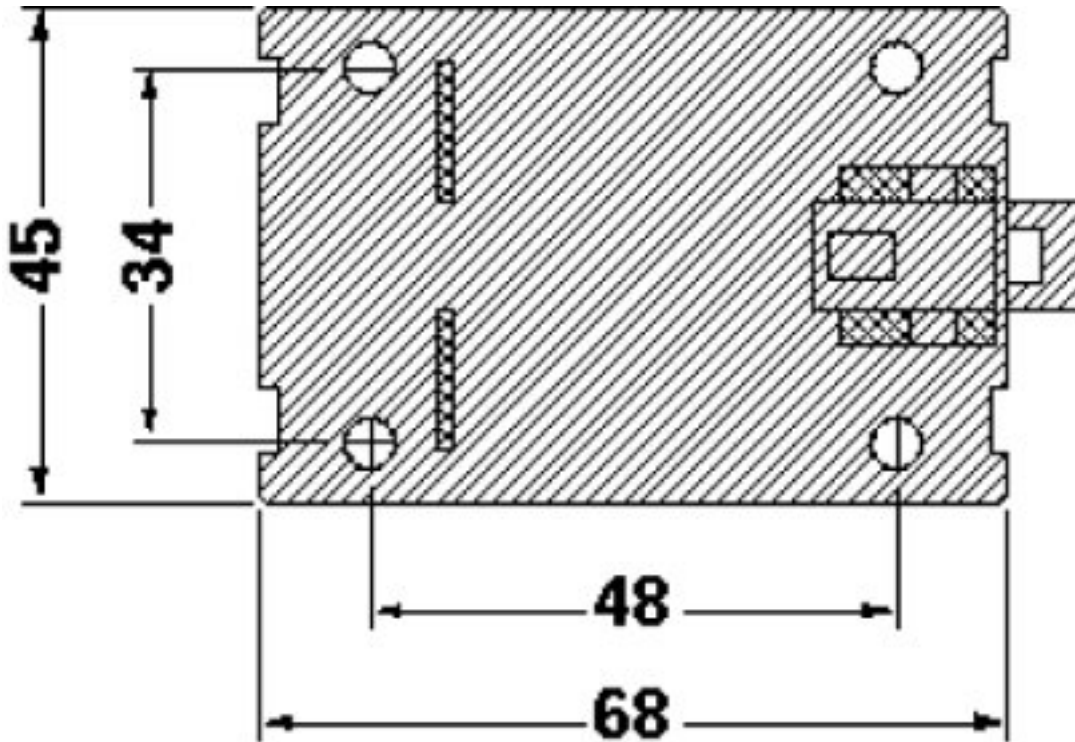

© Phoenix Contact 2013 - all rights reserved
<http://www.phoenixcontact.com>