

Mounting base housing - ME 17,5 UTG/FE GN - 2906937

Please be informed that the data shown in this PDF Document is generated from our Online Catalog. Please find the complete data in the user's documentation. Our General Terms of Use for Downloads are valid (<http://download.phoenixcontact.com>)



Lower part of housing, housing closed, fully assembled, with integrated functional earth ground contact, and metal foot catch

Product Features

- Tool-free mounting
- Large assembly area
- Low design width with a high number of positions
- Recessed labeling areas
- Same PCB geometry for all design widths
- Inflammability class V0 according to UL 94
- Fast mounting on DIN rails according to EN 60715
- Material and part identification embossed on the housing (recyclability)
- Cost savings thanks to easy device production
- Functional earth ground contact (EMC) integrated in the housing base
- Metal foot catch
- Electronic components can be partially removed
- Optional BUS connection integrated in the housing, for either parallel or serial contacting

Key commercial data

package_quantity	10
GTIN	4017918126551

Technical data

General

Housing type	Component housing
Housing material	Polyamide
Color	green

Ambient conditions

Ambient temperature (operation)	-40 °C ... 105 °C
--	-------------------

Dimensions

Length	99 mm
Constructional height	114.5 mm
Width	17.5 mm

Technical data

Mounting base housing - ME 17,5 UTG/FE GN - 2906937

Technical data

Technical data

Inflammability class according to UL 94	V0
Power dissipation at 20°C in the horizontal mounting position	4.9 W 8.9 W
Number of positions	12

classifications

eCl@ss

eCl@ss 4.0	27180401
eCl@ss 4.1	27180401
eCl@ss 5.0	27180506
eCl@ss 5.1	27180506
eCl@ss 6.0	27180802
eCl@ss 7.0	27182702
eCl@ss 8.0	27182702

ETIM

ETIM 2.0	EC001031
ETIM 3.0	EC001031
ETIM 4.0	EC001031
ETIM 5.0	EC001031

UNSPSC

UNSPSC 6.01	31261501
UNSPSC 7.0901	31261501
UNSPSC 11	31261501
UNSPSC 12.01	31261501
UNSPSC 13.2	31261501

approvals

UL Recognized /

Approval details



accessories

Coding element

Mounting base housing - ME 17,5 UTG/FE GN - 2906937

accessories

CR-MSTB - 1734401



CP-MSTB - 1734634



Mounting material

ME-SAS - 2853899



ME LPZS - 2906911



ME MF 17,5 - 2908281



Mounting base housing - ME 17,5 UTG/FE GN - 2906937

accessories

ME LPZS - 2906911



ME MF 17,5 - 2908281



Filler plug

ME B-17,5 MSTBO GN - 2906869



ME B-17,5 MKDSO GN - 2906885



PCB

ME LP - 2906908

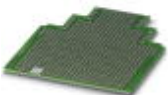

Component housing center part

Mounting base housing - ME 17,5 UTG/FE GN - 2906937

accessories

ME 35 UTM - 2908265



ME 35 UTMG - 2908275



ME 35 UTMG - 2908275



Ground contact

ME FE-CONTACT - 2908294



ME FE-CONTACT - 2908294



Drawings

Mounting base housing - ME 17,5 UTG/FE GN - 2906937

Dimensioned drawing

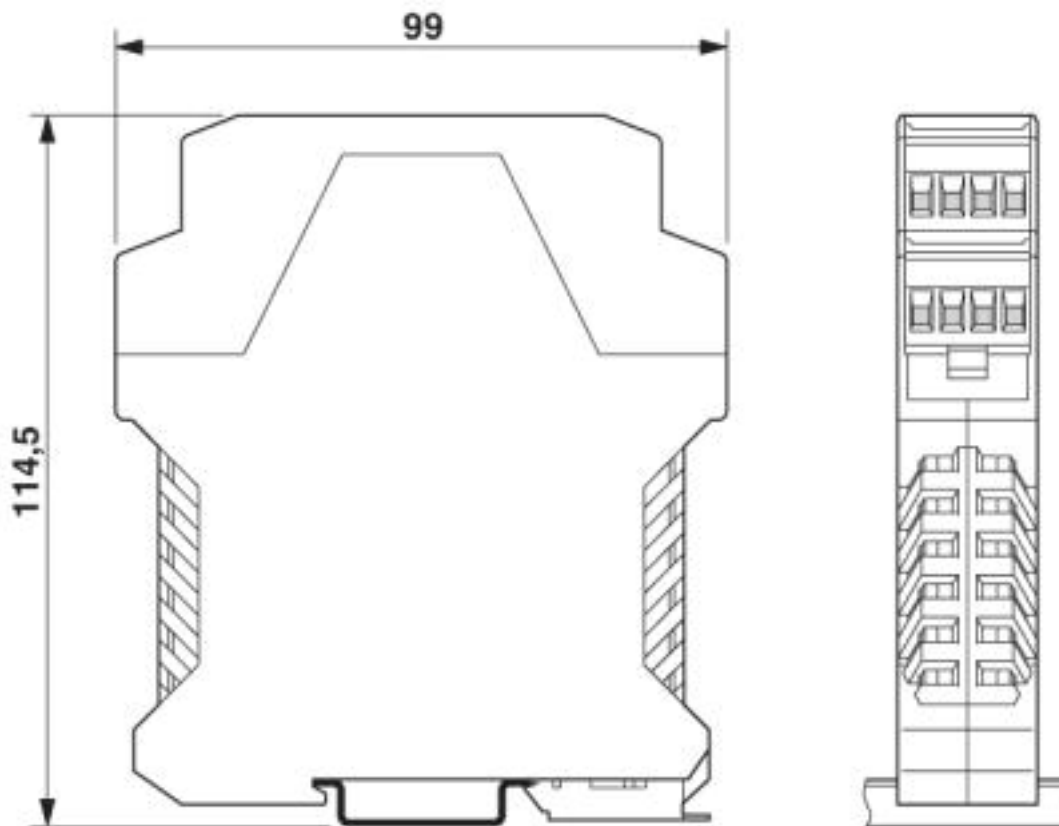

Dimensions of the electronic housing ME... with double-level upper part

Mounting base housing - ME 17,5 UTG/FE GN - 2906937

Dimensioned drawing

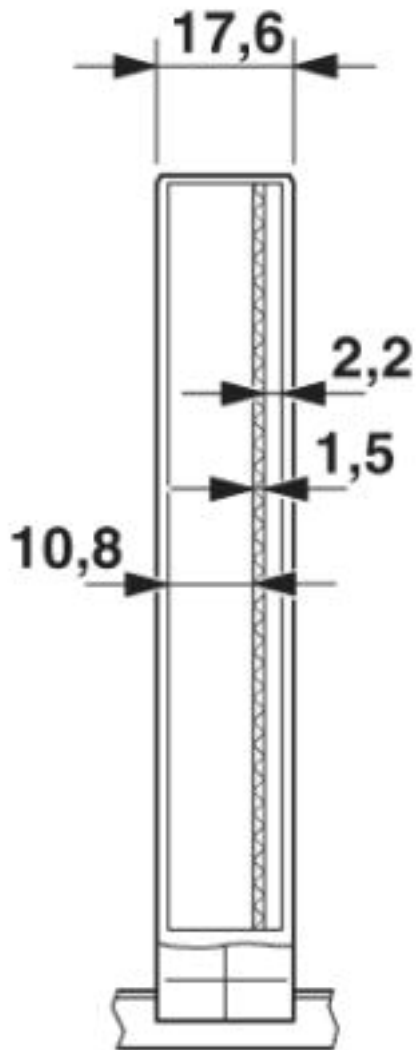

Inner housing dimensions, electronic housing ME 22.5 ...

Mounting base housing - ME 17,5 UTG/FE GN - 2906937

Dimensioned drawing

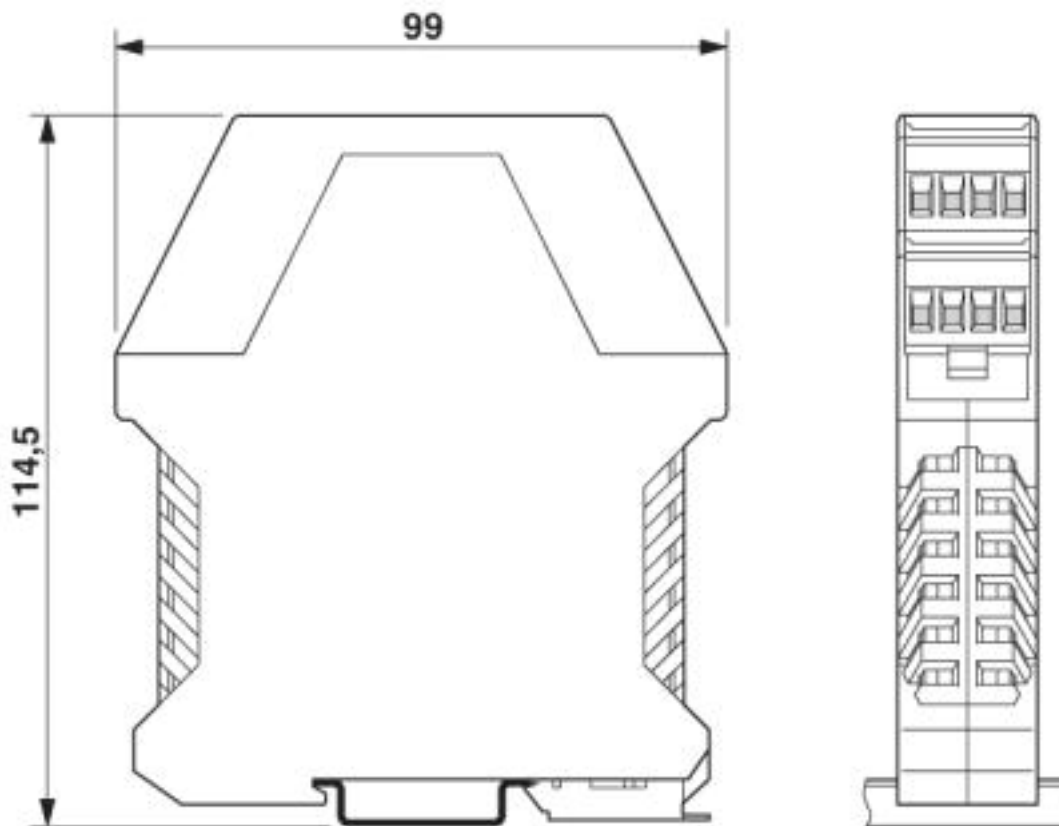

Dimensions of the electronic housing ME... with double-level upper part

Mounting base housing - ME 17,5 UTG/FE GN - 2906937

Dimensioned drawing

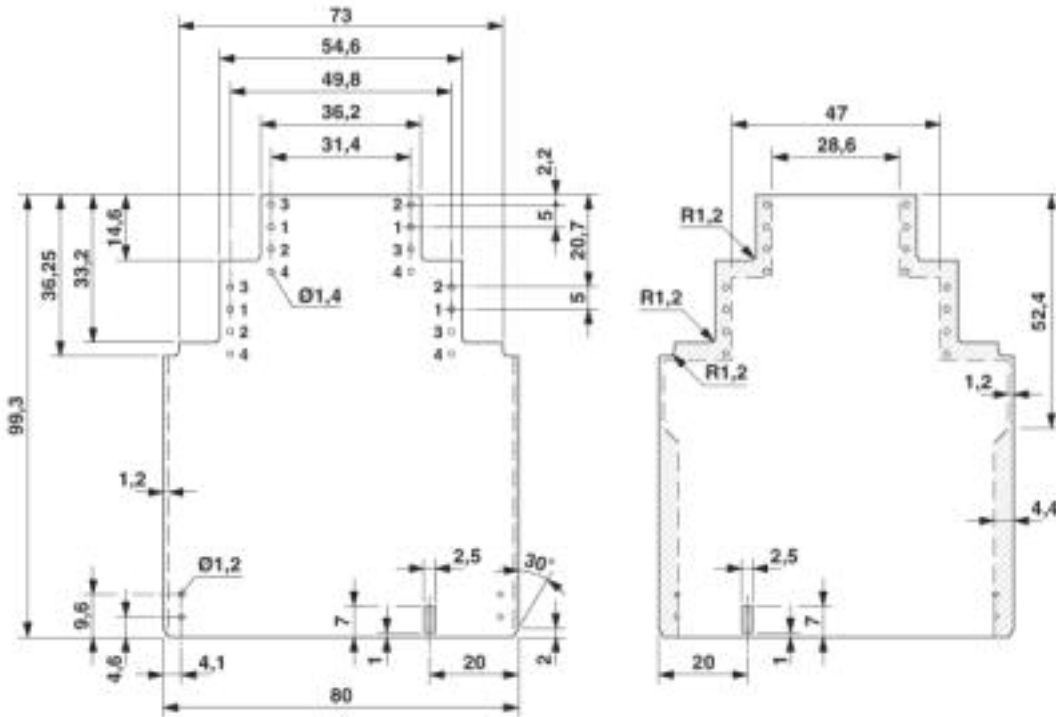

Dimensional drawing of the ME... printed circuit board if the double level upper part is used