

Electronic housing - ME 22,5 UT/FE GN - 2907114

Please be informed that the data shown in this PDF Document is generated from our Online Catalog. Please find the complete data in the user's documentation. Our General Terms of Use for Downloads are valid (<http://download.phoenixcontact.com>)



Lower part of housing, fully assembled, with integrated functional earth ground contact, and metal foot catch.

Product Features

- Tool-free mounting
- Low design width with a high number of positions
- Large assembly area
- Same PCB geometry for all design widths
- Recessed labeling areas
- Fast mounting on DIN rails according to EN 60715
- Inflammability class V0 according to UL 94
- Material and part identification embossed on the housing (recyclability)
- Cost savings thanks to easy device production
- Electronic components can be partially removed
- Metal foot catch
- Functional earth ground contact (EMC) integrated in the housing base
- Optional BUS connection integrated in the housing, for either parallel or serial contacting

Key commercial data

package_quantity	10
GTIN	4017918126605

Technical data

General

Housing type	Component housing
Housing material	Polyamide
Color	green

Ambient conditions

Ambient temperature (operation)	-40 °C ... 105 °C
--	-------------------

Dimensions

Length	99 mm
Constructional height	114.5 mm
Width	22.5 mm

Technical data

Electronic housing - ME 22,5 UT/FE GN - 2907114

Technical data

Technical data

Inflammability class according to UL 94	V0
Power dissipation at 20°C in the horizontal mounting position	6.1 W 12.1 W
Number of positions	16
Number of positions	24

classifications

eCl@ss

eCl@ss 4.0	27180401
eCl@ss 4.1	27180401
eCl@ss 5.0	27180506
eCl@ss 5.1	27180506
eCl@ss 6.0	27180802
eCl@ss 7.0	27182702
eCl@ss 8.0	27182702

ETIM

ETIM 2.0	EC001031
ETIM 3.0	EC001031
ETIM 4.0	EC001031
ETIM 5.0	EC001031

UNSPSC

UNSPSC 6.01	31261501
UNSPSC 7.0901	31261501
UNSPSC 11	31261501
UNSPSC 12.01	31261501
UNSPSC 13.2	31261501

approvals

UL Recognized /

Approval details



accessories

Coding element

Electronic housing - ME 22,5 UT/FE GN - 2907114

accessories

CR-MSTB - 1734401



CP-MSTB - 1734634



Component housing center part

ME 45 UTM GN - 2853404



ME 45 UTM G GN - 2853417



ME 45 UTM GN - 2853404



Mounting material

Electronic housing - ME 22,5 UT/FE GN - 2907114

accessories

ME-SAS - 2853899



ME LPZS - 2906911



ME MF 17,5 - 2908281



ME MF 17,5 - 2908281



PCB

ME LP - 2906908

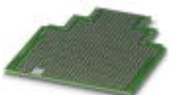

Filler plug

Electronic housing - ME 22,5 UT/FE GN - 2907114

accessories

ME B-22,5 MKDSO GN - 2907143



ME B-22,5 MSTBO GN - 2907156



ME B-12,5 3MSTBO GN - 2709176



Ground contact

ME FE-CONTACT - 2908294



ME FE-CONTACT - 2908294



Drawings

Electronic housing - ME 22,5 UT/FE GN - 2907114

Dimensioned drawing

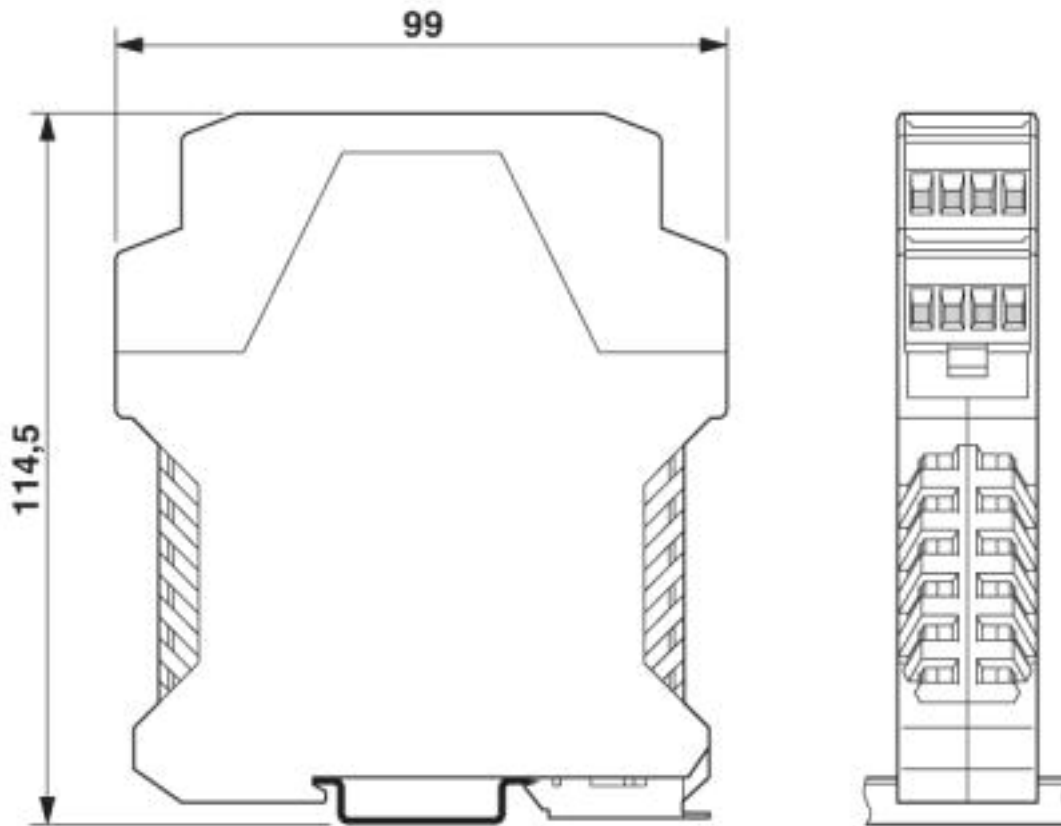

Dimensions of the electronic housing ME... with double-level upper part

Electronic housing - ME 22,5 UT/FE GN - 2907114

Dimensioned drawing

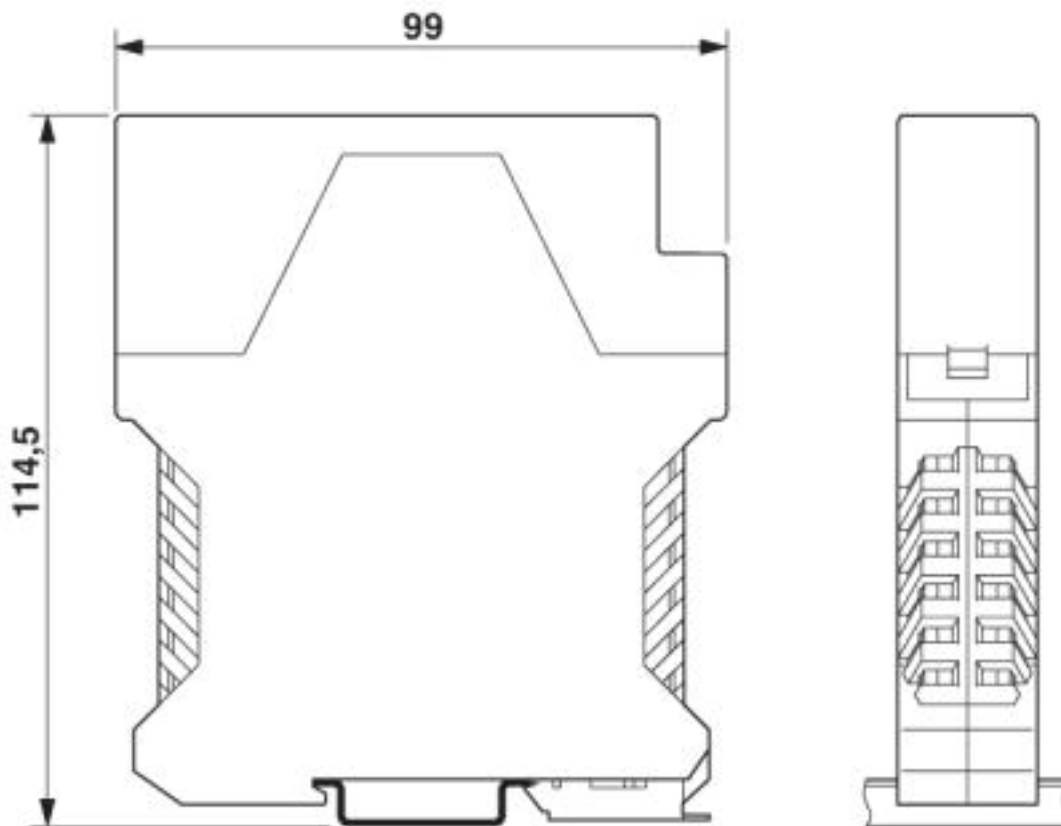

Dimensions of the electronic housing ME... with single-level upper part

Electronic housing - ME 22,5 UT/FE GN - 2907114

Dimensioned drawing

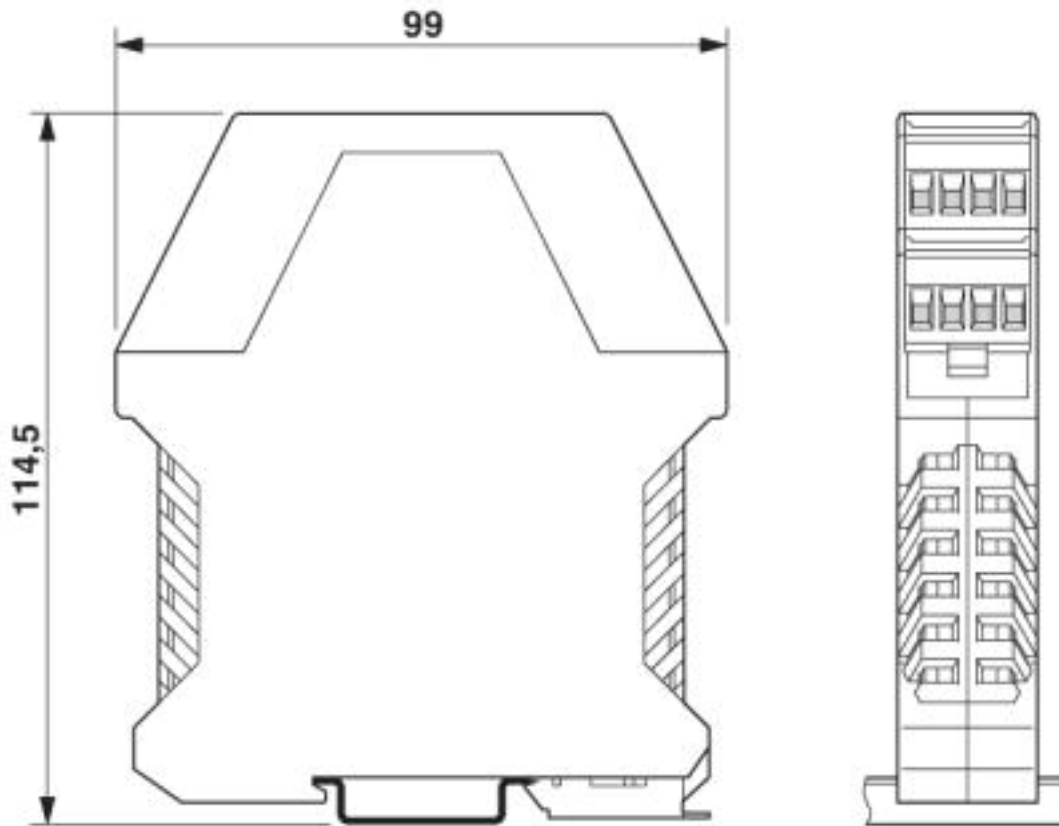

Dimensions of the electronic housing ME... with double-level upper part

Electronic housing - ME 22,5 UT/FE GN - 2907114

Dimensioned drawing

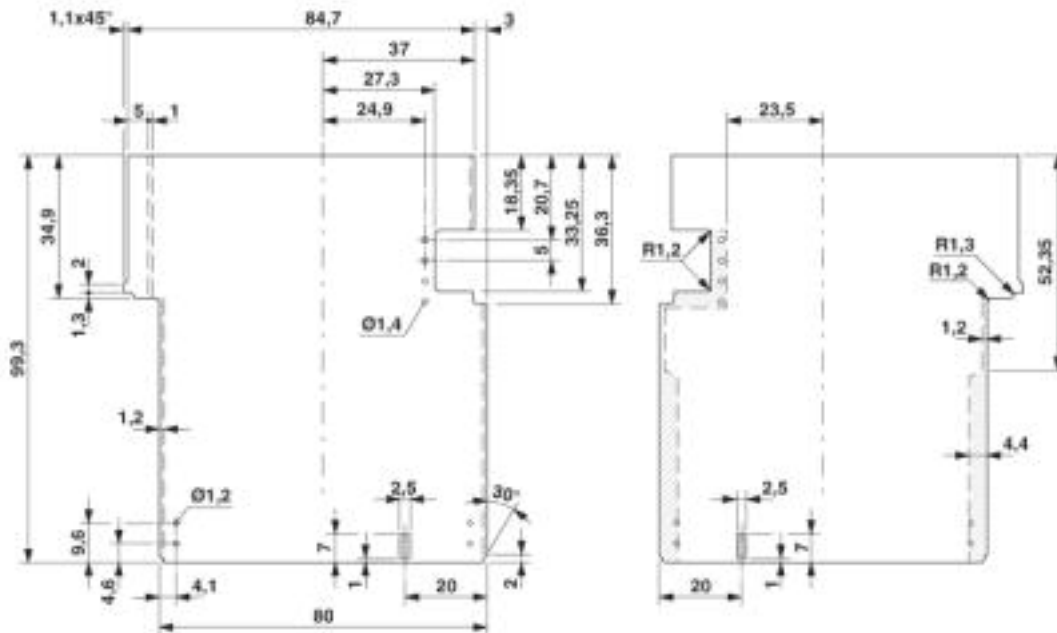

Dimensional drawing of the ME... printed circuit board if the single level upper part is used

Dimensioned drawing

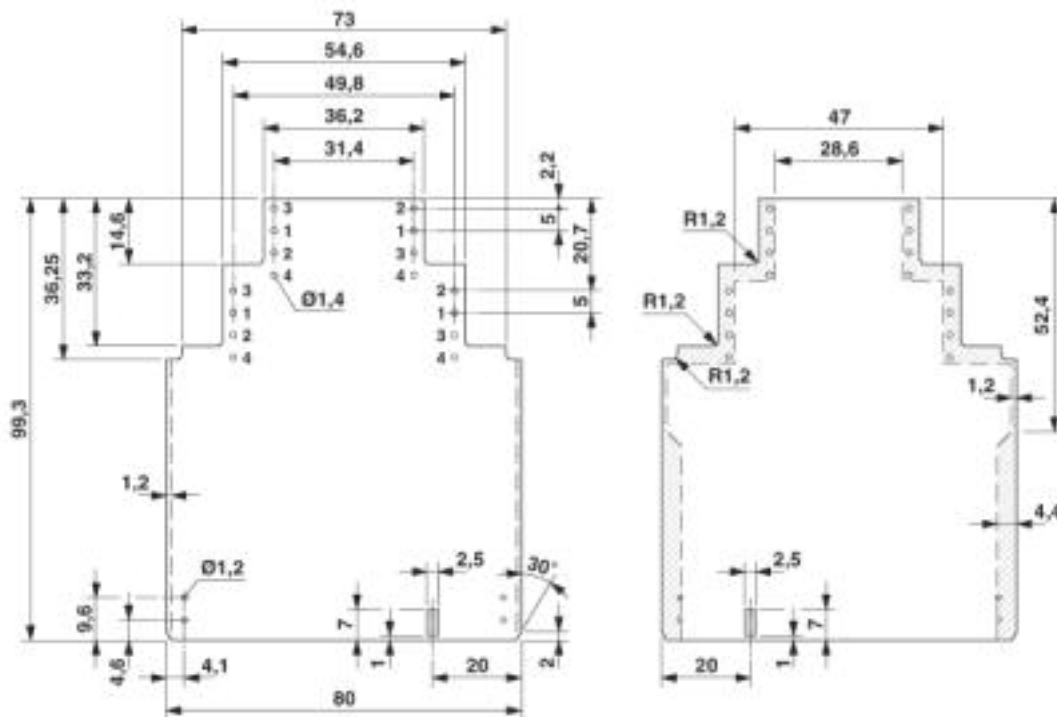

Dimensional drawing of the ME... printed circuit board if the double level upper part is used

Electronic housing - ME 22,5 UT/FE GN - 2907114

Dimensioned drawing

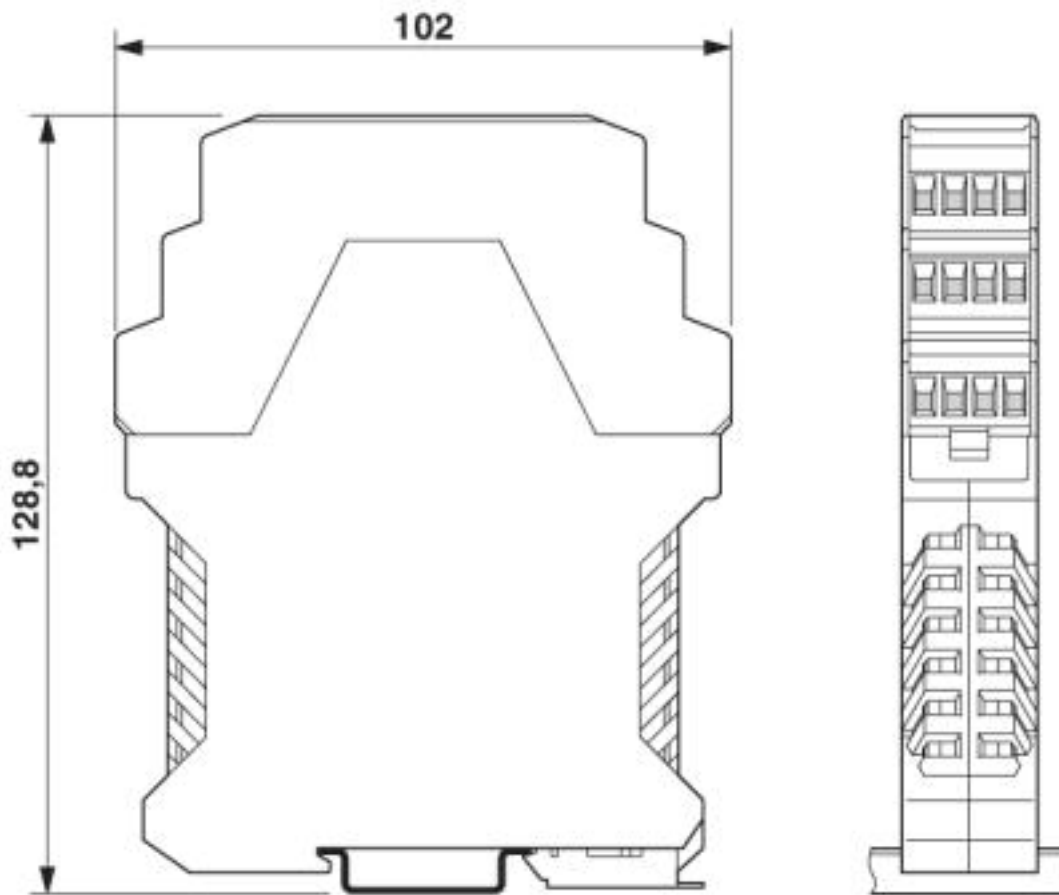

Dimensional drawing of the ME... printed circuit board if the triple-level upper part is used

Electronic housing - ME 22,5 UT/FE GN - 2907114

Dimensioned drawing

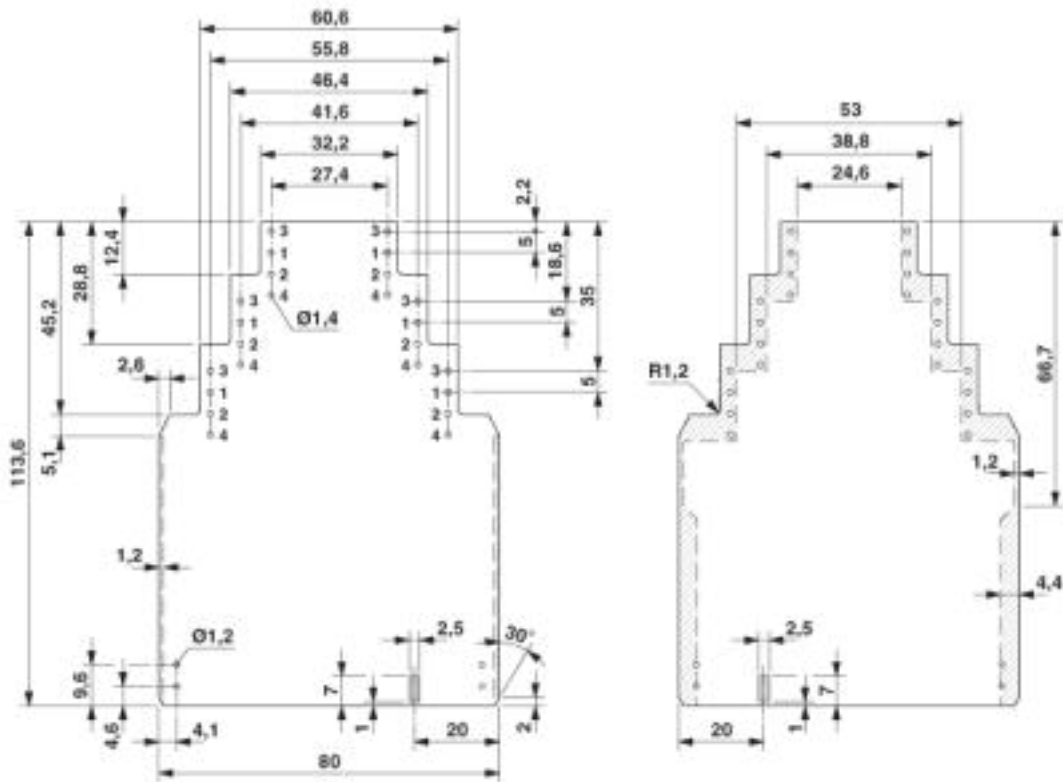

Dimensional drawing of the ME... printed circuit board if the triple-level upper part is used

Electronic housing - ME 22,5 UT/FE GN - 2907114

Dimensioned drawing

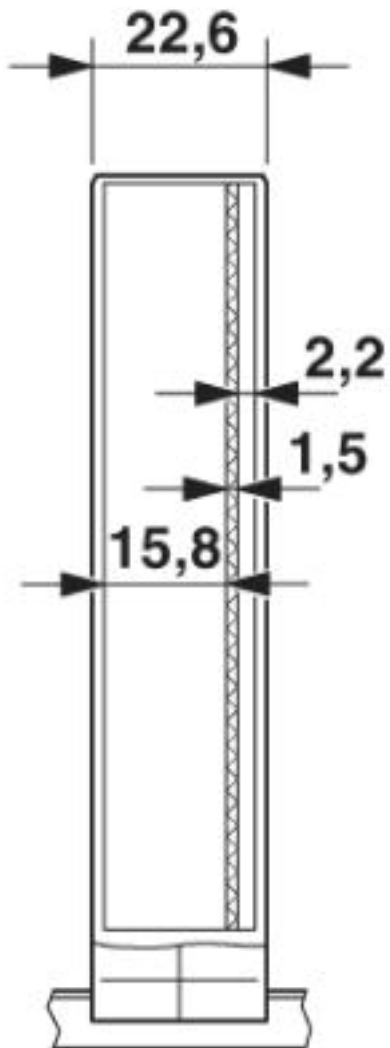

Inner housing dimensions, electronic housing ME 22.5 ...

© Phoenix Contact 2013 - all rights reserved
<http://www.phoenixcontact.com>