



GOLD CAPACITORS

TECHNICAL GUIDE



Table of Contents

1.	Introduction	3	
2.	Principles and Operation of Gold Capacitors	4	
	2.1	What are Electric Double Layer Capacitors?	4
	2.2	Construction and Principles of Operation	5
	2.3	Equivalent Circuit	6
	2.4	Electrical Characteristics	8
	2.5	Features	10
3.	Product Types & Selection Method for Gold Capacitors	12	
	3.1	Gold Capacitor Series	12
	3.2	Construction, Features and Applications	13
	3.3	Applications and Recommended Series	16
	3.4	How to Select a Gold Capacitor	17
4.	Operating Techniques of Gold Capacitors	17	
	4.1	Life Design	17
	4.2	Notes on the use of Electric Double Layer Capacitors	19
	4.3	Checklist when Ordering Product	23
5.	Gold capacitors Characteristics	24	
6.	Storage Capabilities	37	
7.	Product Specifications	39	

Electric Double Layer Capacitors were first developed by the Central Research Laboratory of Panasonic in 1972, then marketed and sold on a worldwide basis in 1978. Because these capacitors function like a battery, they are ideally suited for applications requiring a secondary power source such as a back-up energy source for microprocessors and solar batteries.



Compared to other capacitors and batteries, Gold Capacitors are very new. We have summarized the characteristics and reliability of Gold capacitors in this manual. Panasonic has developed the Gold Capacitor to meet most of your design needs. We hope you will find this manual informative and useful.

2-1 What are Electric Double Layer capacitors?

In general, capacitors have a dielectric sandwiched between two opposing electrodes. An aluminum electrolytic capacitor, as an example, uses an aluminum oxide film, while a tantalum capacitor uses tantalum oxide film as a dielectric.

However, an electric double layer capacitor (EDLC) does not have a dielectric but uses a physical mechanism that generates a double electric field which acts like a dielectric, hence the name Electric Double Layer Capacitor. Charging-discharging occurs in the ion absorption layer which is formed on the surfaces of the positive and negative electrodes of activated carbon.

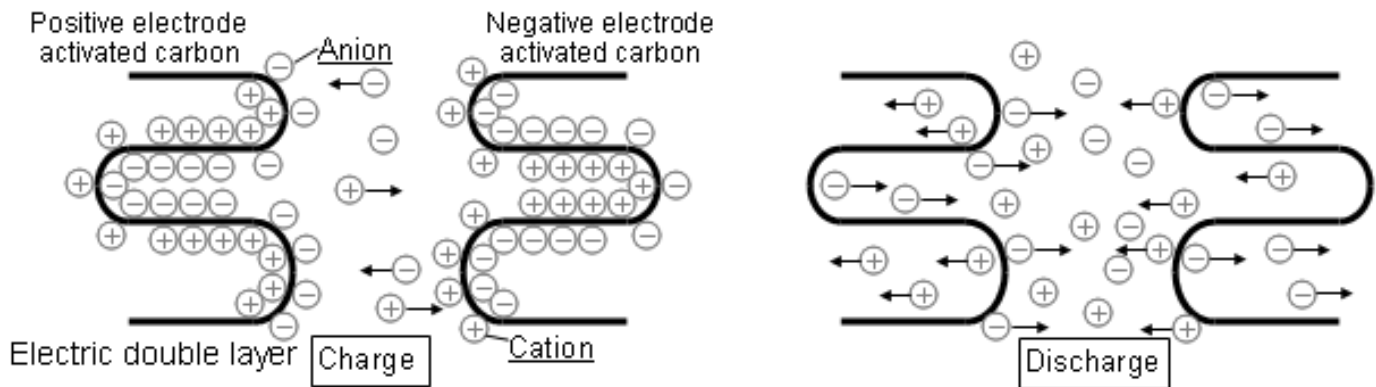

(Fig.1)

There are 2 types of electrolytes used by EDLC manufacturers. One is water-soluble and the other is non-water soluble. The non-water soluble electrolyte can increase the withstand voltage per cell compared to that of a water-soluble electrolyte. Panasonic's Gold Capacitors are made with non-water soluble electrolytes, and feature a small size and light weight.

The capacitance range of a Gold Capacitor is mid-range between an aluminum electrolytic capacitor and a secondary battery. A Gold Capacitor is mostly used as a back up for a battery or a secondary battery.

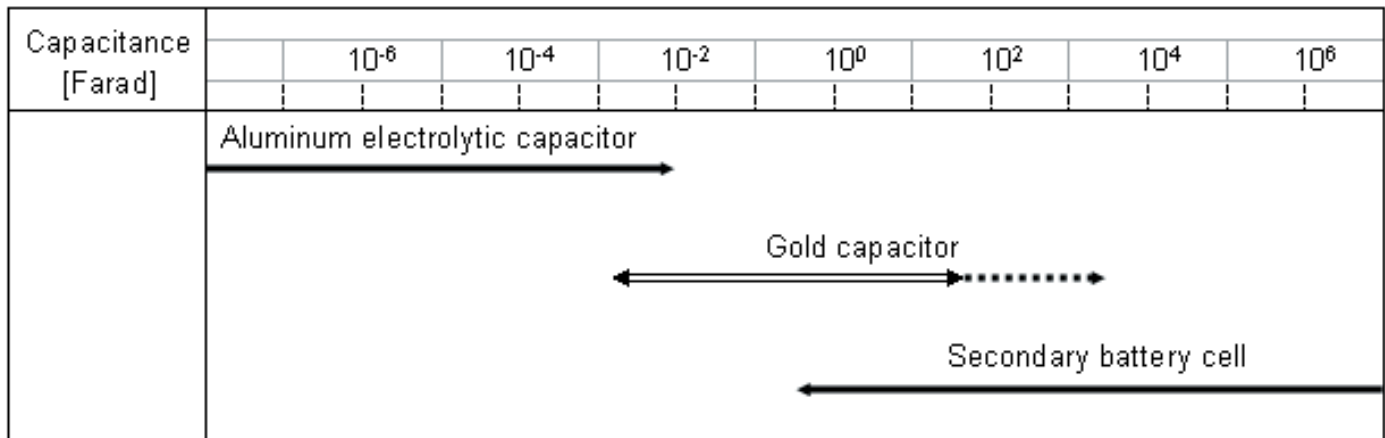

Smaller Gold Capacitors with greater capacitance can be used in memory back up for microcomputer's RAM during power failure. Equipment that can also use a Gold Capacitor during power failures include video recorders, DVD players, fax machines, telephones, digital still cameras, mobile phones, audio stereo systems, etc. Capacitors for hybrid power sources combined with solar cells are also becoming popular because of the nuisance of exchanging primary cells. Having a device that uses a Gold Capacitor is very convenient for users in areas where batteries cannot easily be obtained.

We have also products available that have greater capacitance to comply with the following requirements:

- For loading a large amount of current in a short time, (e.g. solenoid absorption of hot-water gas heaters and protection of HDD head requesting several mA to several 100mA of current.
- Load for lighting equipment.

2-2 Construction and Principles of Operation

A cross-sectional drawing of a coin shaped single cell Gold Capacitor is shown in Fig.2.

The electrode within the cell is made from activated carbon. The electrode is then impregnated with an electrolyte. A separator with high insulating properties against ion penetration is then positioned between both electrodes to prevent short circuiting. Then packing is added between the top cover and bottom case to seal.

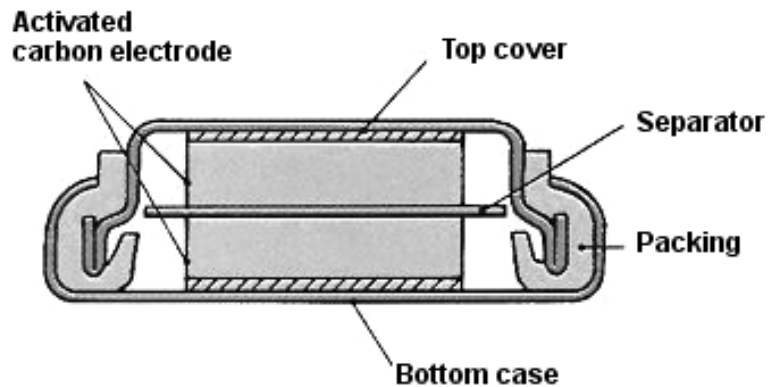

(Fig.2)

Negative and positive electric charges are then formed between the solid activated carbon fibers and the liquid electrolyte. The boundary area between these charges is the electric double layer. This can be seen in Fig.3. The area increases as higher voltages are applied. The higher voltage increases the charge as shown in Fig.4.

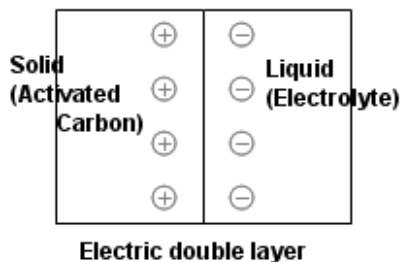

(Fig.3)

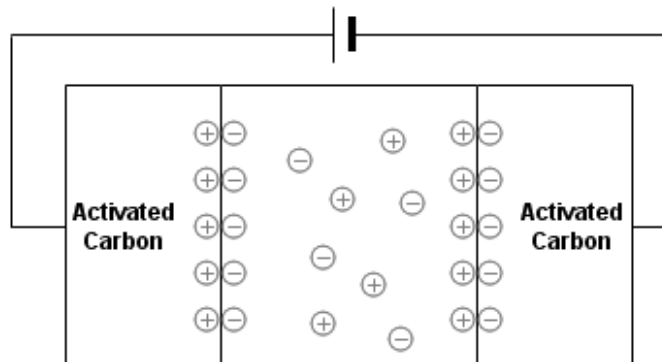

(Fig.4)

The electric double layer acts as an insulator and does not allow current to flow when an external DC voltage is applied. As the voltage level is increased, a point is reached where the current will begin to flow. The magnitude of this voltage is called the “decomposition voltage”. Further increasing this voltage will cause the electrolyte to decompose causing additional current to flow.

The withstand voltage of a Gold Capacitor is determined by the decomposition voltage and varies by number of capacitors used in series.

Gold capacitors use an activated carbon electrode and an organic electrolyte. The electric double layer is very thin, like a molecule, and the electrode uses a large surface activated carbon, allowing a high capacitance (in farads) to be attained. The withstand voltage per single cell is also high and the product can be miniaturized because it uses organic electrolytes.

2-3 Equivalent Circuit

The equivalent circuit used for conventional capacitors can also be applied to Gold Capacitors.

In an electric double layer capacitor, the electric double layer is formed on the surface of the activated carbon that is in contact with the liquid electrolyte. As shown in Fig.5.

Because the activated carbon particles are used as electrodes, each carbon layer (Fig.5) functions as an electric double layer capacitor having the capacitance value of C_n .

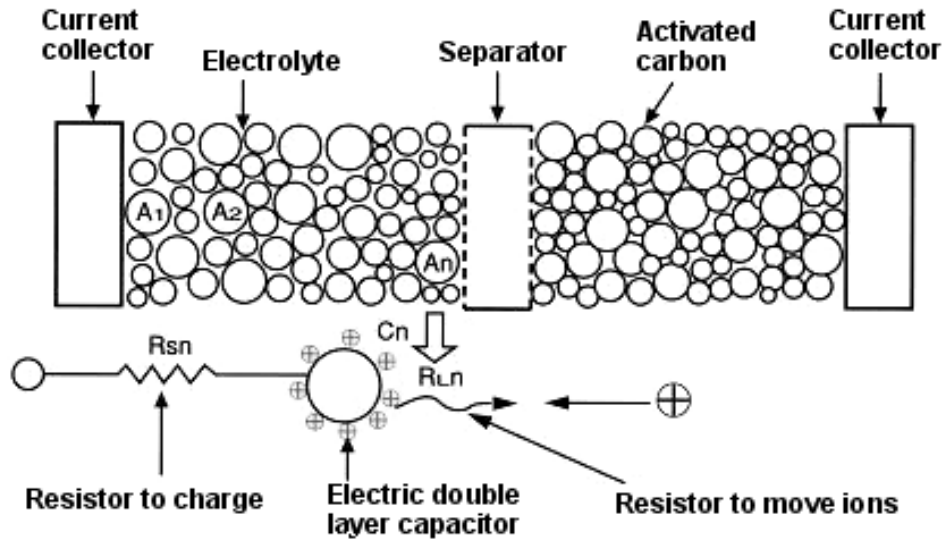

(Fig.5)

In order for the capacitance C_n to charge, two resistances are needed as described in Fig.6.

The resistance R_1 moves ions while resistance R_s is the charging resistance. The double layers formed on the activated carbon surfaces can be shown as parallel circuits.

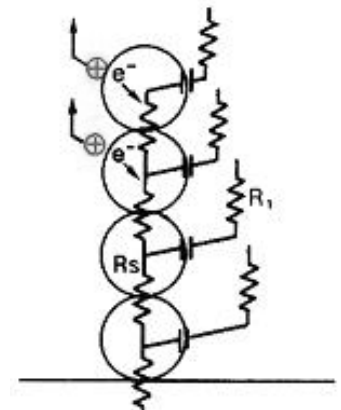

Particle type
activated carbon

(Fig.6)

The resistance values can increase or decrease depending on the distance between the current collectors, speed or ions, contact resistance between the activated carbons, etc. The equivalent circuit of an electric double layer capacitor is shown by the parallel R-C combinations (Fig.7).

R_1 , R_2 and R_n are the internal resistance of the activated carbons. C_1 , C_2 and C_n are the electrostatic capacitance of the activated carbons having resistances R_1 , R_2 and R_n .

If voltage(V) is applied to the equivalent circuit shown in Fig.8, the charging current(i) will vary according to Equation 1 shown below. It should be noted that the charging current(i) decreases as charging time increases and is shown in Fig.9. The charging current given by equation (1) will graphically be shown as a straight line. However, the actual charging current curve is exponential.

$$(1) \quad i = \frac{V}{R} \exp\left(-\frac{t}{CR}\right)$$

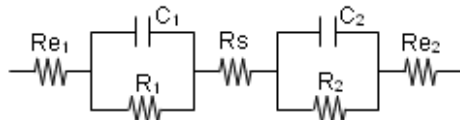

C_1, C_2 : Electric double layer capacity
 Re_1, Re_2 : Electrode resistance
 R_1, R_2 : Insulation resistance
 Rs : Separator resistance

(Fig.8)

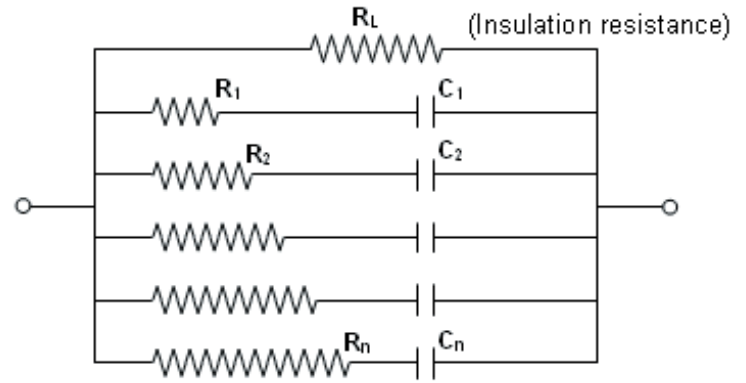

(Fig.7)

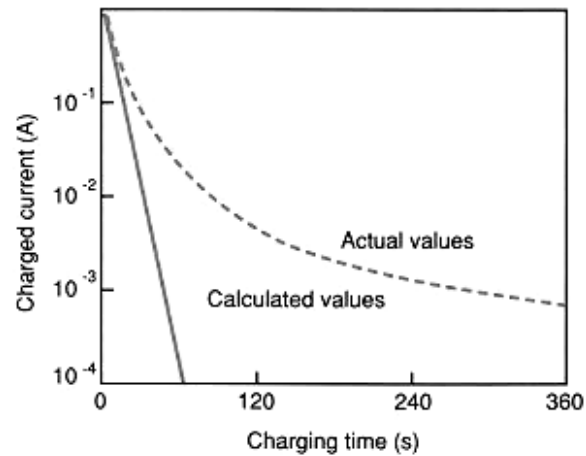

(Fig.9)

If one considers the equivalent circuit of the electric double layer capacitor (Fig.8) as having many small capacitors (C_n) with various internal resistance (R_n), then the current that flows through an individual capacitor can be represented by Equation 2.

$$(2) \quad i_n = \frac{V}{R_n} \exp\left(-\frac{t}{C_n R_n}\right)$$

Therefore, the current (i) within the capacitor can be regarded as the sum ($\sum i_n$) of the currents flowing through each of the small capacitors. It also can be seen that if the $C \times R$ value is small, the charging time will be short. Conversely, if the $C \times R$ value is large, the charging time will be long. The sum of the small capacitor charging currents is shown in Fig.10.

It should be noted that if the charging time is limited to only several minutes, or the charging source is current limited, the Gold Capacitor may not be sufficiently charged to provide the required back-up energy for the time needed. If the capacitor is not sufficiently charged and is called upon to discharge its energy into a load, the discharge current will flow from a high voltage level to a low voltage level thereby causing a low terminal voltage. These conditions are shown in Fig.11, 12.

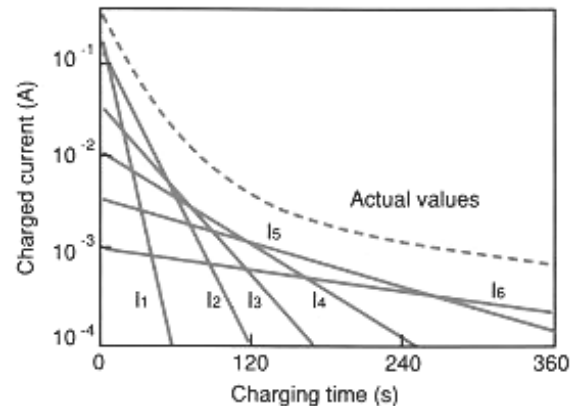

(Fig.10)

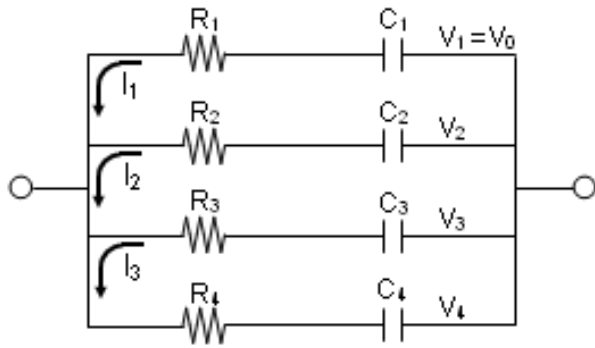

Just after charging $V_0 = V_1 > V_2 > V_3 > V_4$
 After discharging $V_0 > V_1 = V_2 = V_3 = V_4$

(Fig.11)

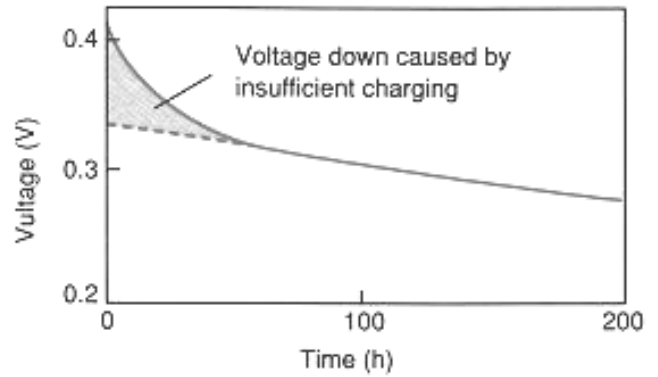

(Fig.12)

2-4 Electrical characteristics of Electric Double Layer capacitor

2-4-1 Electrostatic capacitance

The electrostatic capacitance of an electric double layer capacitor basically varies similarly as that of a battery under the same use or test conditions and it is commonly referenced as the Effective Capacitance. This is commonly referenced to as the Effective Capacitance.

As previously stated, the electric double layer capacitor is comprised of a small capacitor having various values of resistance. Therefore, in order to measure the electrostatic capacitance, measurement parameters such as charge voltage and charge time must be defined.

If the starting voltage is set slightly below the fully charged voltage value (V_0), then the voltage down condition (Fig.13) will occur at the start of the measurement. This is due to small capacitors with large internal resistance not being fully charged which results in a large voltage drop at the start of the measurement. Under this condition, the measured capacitance value will be small. However, by increasing the charging time, these small-high resistance capacitors with high resistances will become charged and the voltage lost during the voltage down condition will be small, resulting in a high measured value of capacitance (Fig.13).

Electrostatic capacitance is also current dependent. If a large amount of current is quickly discharged, or the capacitor has been on discharge for a long period of time, the resultant electrostatic capacitance will be small. Conversely, if the discharge current is small, or the discharge time short, the measured electrostatic capacitance will be large. Therefore, in order to have measurement consistency we have adopted the standard discharge current of 1mA/F.

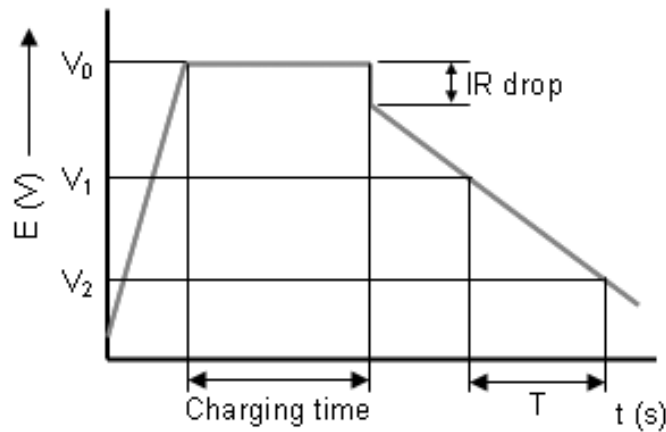

(3)

$$C = \frac{I \times T}{(V_1 - V_2)} \quad (\text{Farad})$$

C: Electrostatic capacitance(F)

I: Test current(A)

T: Test time(s)

V1 - V2: Testing voltage range(V)

(Fig.13) Electrostatic capacitance test

2-4-2 Internal Resistance

The equivalent circuit of an electric double layer capacitor consists of many small capacitors having various internal resistance values. Normally, the values of these resistors would be expressed in DC values. However, so that a true picture may be established, we will use impedance (@ 1kHz) as the parameter and being that the DC resistance and Z value are not equal, we must consider their relationship under current conditions.

2-4-3 Current

If current is measured 30 to 60 minutes after applying the rated voltage, a resulting large current (several 10μA) will be present. This is due to the fact that the measured current is the sum of the charging currents that are flowing through the many small capacitors shown in the equivalent circuit. As it is extremely difficult to determine the leakage current of electric double layer capacitors, the current value specified as the leakage current is somewhat meaningless. It takes a minimum of 10 hours to fully charge the capacitor so that a meaningful leakage current value can be obtained.

2-4-4 Charging Characteristics

The charging characteristics of an electric double layer capacitor can be represented by equation (4):

$$(4) \quad V = V_0 \left\{ 1 - \exp\left(-\frac{t}{CR}\right) \right\}$$

Because of the many internal resistances within the electric double layer capacitor, no external current limiting resistor is needed.

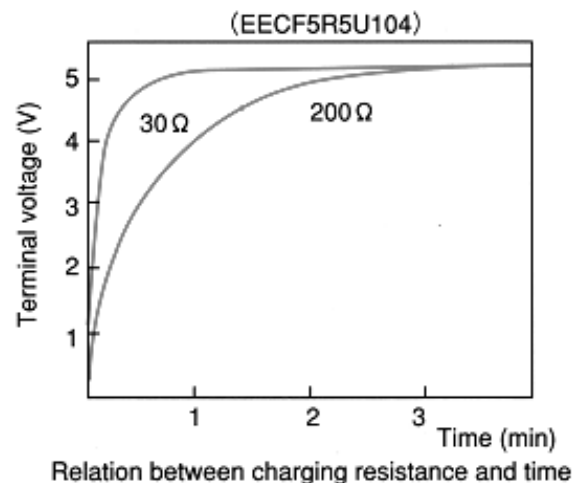

(Fig.14)

2-4-5 Discharging Characteristics

Self discharge characteristics

The self discharge characteristics of an electric double layer capacitor are shown in equation (5).

$$(5) \quad V = V_0 \exp\left(\frac{-t}{C R_L}\right)$$

where R_L is insulation resistance

With a fully charged capacitor, the amount of voltage that is lost at the terminals is equal to the amount caused by the self-discharge leakage current. However, if the capacitor has not reached the fully charged state, the rate at which the terminal voltage changes over time is shown in Fig.15.

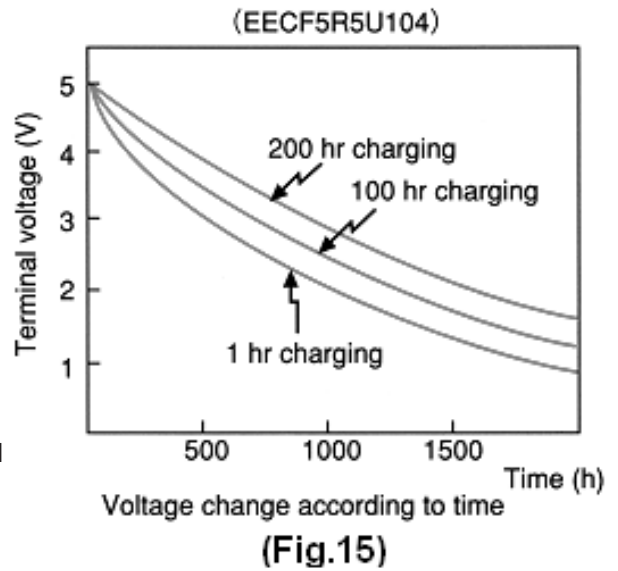

Characteristics of Constant Current and Constant Resistance Discharging

The time required for the constant current and constant resistance discharging are respectively presented by the equations (6) and (7) below:

Discharging time (t) of constant current discharge

$$(6) \quad t = \frac{C(V_0 - V_1)}{I}$$

Discharging time (t) of constant resistance discharge

$$(7) \quad t = -C R \ln\left(\frac{V_1}{V_0}\right)$$

- t : Charging time
- C : Capacitance
- V_0 : Initial voltage
- V_1 : Terminal voltage after t(s)
- I : Constant current load
- R : Constant resistance load

The above equations may not always be accurate, as the terminal down voltage must be considered after the start of discharge if load resistance or load current is present.

Backup Characteristics for IC

If the capacitor is used as a back-up for an integrated circuit, the V-I characteristics of the integrated circuit must also be considered. It can, therefore, be said that if the voltage is low, the current is also low and the actual back-up time will be longer than that calculated. To be certain that the capacitor selected is of sufficient value to maintain the necessary energy and time, it should be checked and measured under actual operating conditions.

2-5 Features

The capacitance of an electric double layer capacitor can be expressed by equation (8):

$$(8) \quad C \propto \frac{S}{d}$$

d = thickness of electric double layer
s = area of an activated carbon

The area of activated carbon is approximately 2500 cm²/gram and the thickness of a double layer is less than a molecule. From this, it can be readily seen that the capacitance of an electric or double layer capacitor is several times greater than of an aluminum electrolytic capacitor.

The internal resistance of an electric double layer capacitor is quite high compared to an aluminum electrolytic capacitor and, therefore, it should not be used as a filter in an AC circuit. These devices are specifically designed for energy back-up applications and secondary power sources.

Wide Range of Models for a Variety of Applications

Panasonic offers a wide range of Gold capacitors. The coin type Gold Capacitors are primarily used as real time clock back-up, while the radial types can handle large currents.

As a Secondary Source with Long Life

Gold Capacitors are as durable as Aluminum Electrolytic Capacitors. In fact, when it is used under proper conditions, (refer to “the Life” in details), they are as durable as the equipment itself. Therefore, there is no need to replace the battery. It is also worth noting that there are many international regulations for batteries. This makes Gold Capacitors a better choice.

Wide Operating Temperature Range

Batteries tend to lose much of their energy when exposed to heat and are susceptible to leakage when exposed to low temperatures (e.g. below 0°C). Gold capacitors are suitable where the operating temperature conditions are taken into consideration, such as in car stereos, etc.

No Need of Charge Control

Ni-Cd batteries generate heat in over-charged and discharged conditions, which shortens its life, creating a need for a charge control circuit. Gold Capacitors have no limit on charging and discharging and do not need a charge control circuit.

Speed Charge, Repeated Charge/Discharge Cycles

Speed charge is possible for Gold Capacitors. Repeated rapid charge and discharge cycles are acceptable because there is no internal chemical reaction like a battery. Gold Capacitors are ideally suited for circuits that have short repetitive charging and discharging time, and can not take long charging times.

Good for the Environment as a Secondary Source

There are no toxic materials such as cadmium or mercury in Gold Capacitors. Europe has recently restricted the use of products containing toxic materials due to pollution. Solar watches use our Gold capacitors and are very popular with clean energy initiatives in Europe. Thus, Gold Capacitors are well suited for use in Europe and America where these restrictions apply.

Product Type & Selection Method of Gold Capacitors

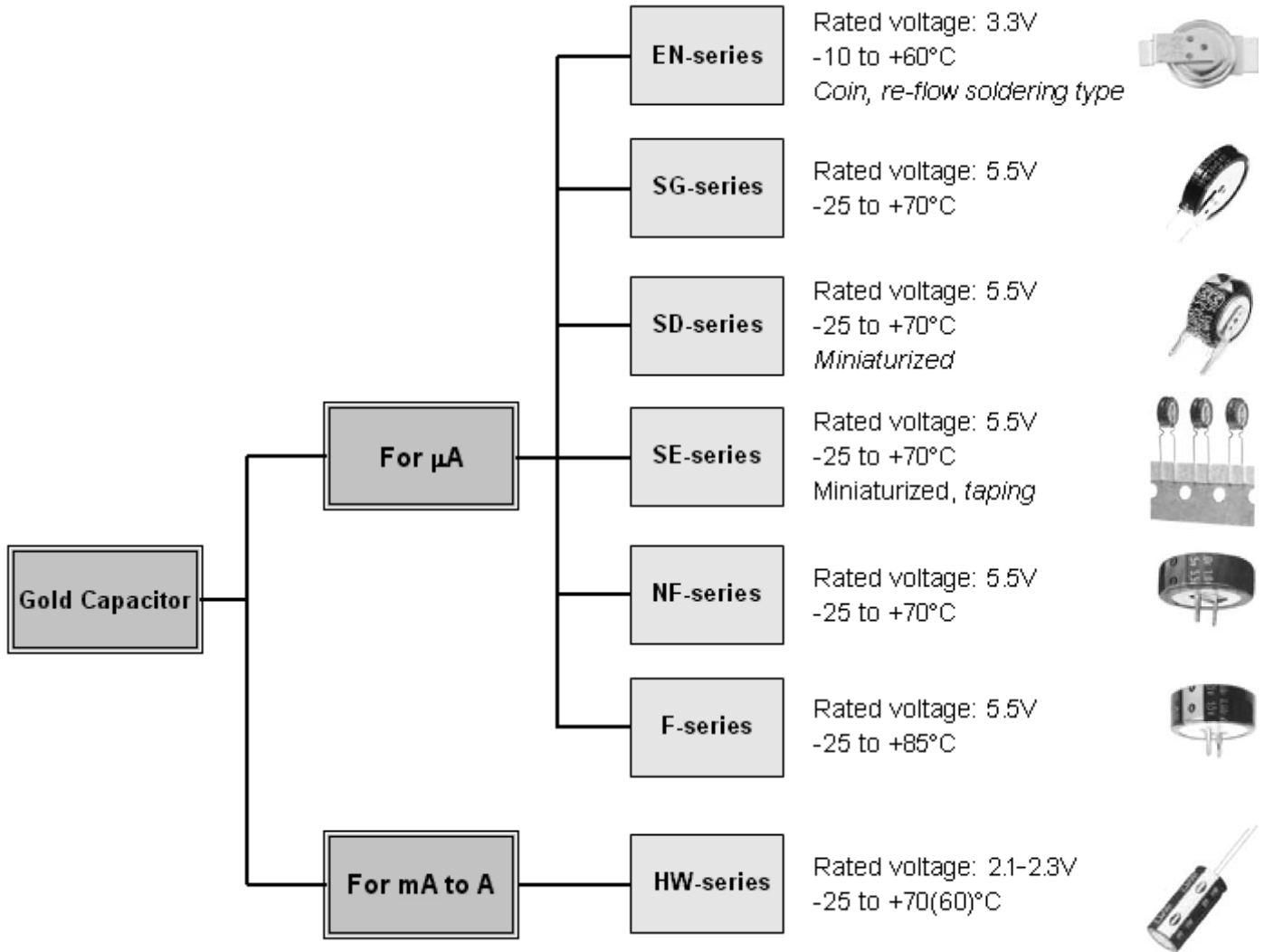

Capacitance Range

Series	Capacitance Code																	
	223	333	473	104	224	334	474	684	105	155	205	335	475	106	226	306	506	706
EN 3.3V					O*													
SG 5.5V							O		O	O								
SD 5.5V	O		O	O	O	O												
SE 5.5V	O		O	O	O													
NF 5.5V	O		O	O	O		O		O	O								
F 5.5V		O	O	O			O	O	O									
HW 2.3V									O			O	O	O	O	O	O	●*

Capacitance code: 223=0.022F, 104=0.1F, 106=10F *EN224=0.2F

●* = 2.1V

3-2 Construction, features and applications of each type

3-2-1 Coin type

Basic Construction

The structural drawing of a Coin type Gold capacitor is shown in Fig.16.

The activated carbon used as the electrode is solidified in powder activated carbon. This activated carbon is connected with the cover and the case through a conductive point. This separator functions as an insulator but does not restrict the movement of ions through it. Packing is added to seal the cover and case.

Features

The physical appearance looks a Coin type battery (Fig. 17). Unlike batteries, type “E” Gold Capacitor does not need a charge/discharge control circuit, and are good for the environment.

Applications

1. Memory back-up during battery replacement of mobile phones, digital still cameras and PDAs.
2. Secondary power source for solar watches.

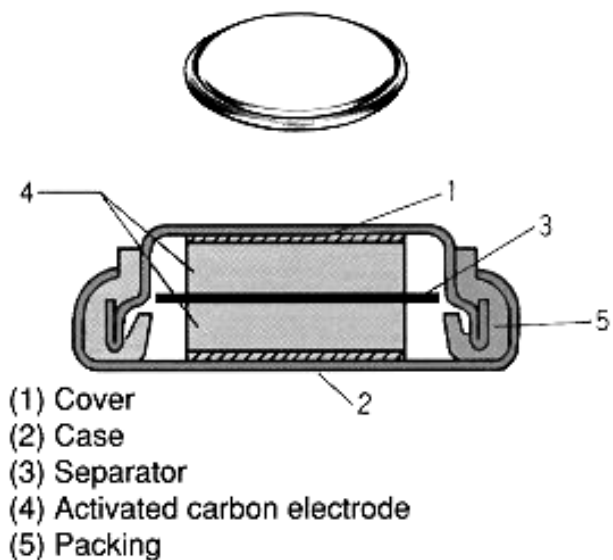

(Fig.16)



EN-series φ6
(Fig.17)

3-2-2 F & NF series

Basic Construction

Both the **F** and **NF** series capacitors are constructed with 2 or 3 coin style cells series, connected with a spring plate. (Fig.18)

Features

The maximum operating temperature of the **F** series Gold Capacitor is 85°C, which is suitable for products used in relatively high temperatures (e.g. car audio etc.). The Gold Capacitor also has longer life compared to others, particularly in the 70°C range. Low profile design (70°C guarantee) is also available for **NF** series. We also have low profile products (70°C guarantee) for **NF** series.

Applications

F series

1. Memory back-up for equipment used at high temperatures (car audio, industrial robot, etc.)

2. Memory back-up for equipment required long life (computer, office apparatus, etc.)

NF series

Memory back-up for low-profile equipment (video, audio, etc.).

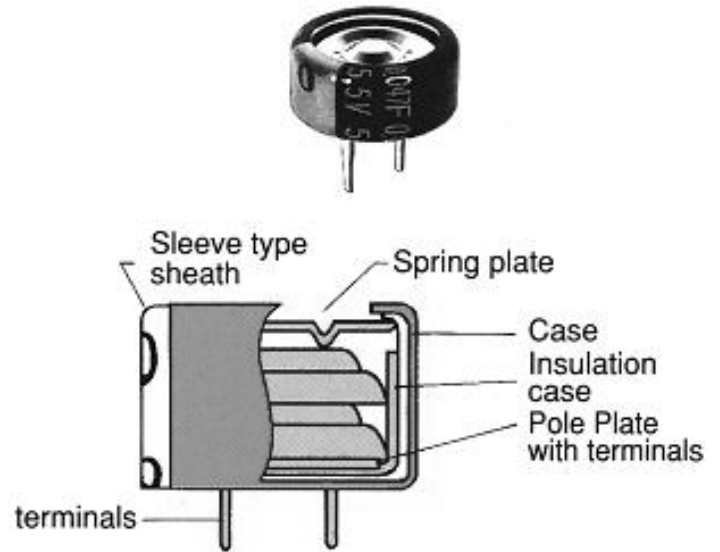

(Fig.18)

3-2-3 SG, SD and SE series

Basic Construction

The SG Gold Capacitor is constructed from two cells (series connected) in a connector cup and welded with terminals in it. It is the smallest construction within the series. (Fig.19)

Features

Type SD series are designed for miniaturization. There are type H for low profile (Fig.20) and type V for reduction of mount area (Fig.21). SE series (Fig.22) has a standard packaging format of tape and box for automatic insertion. These products are small and light, and can be used for general equipment.

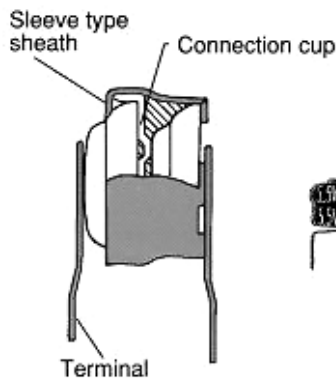

(Fig.19)



(Fig.20)



(Fig.21)

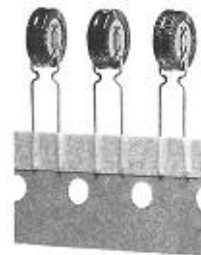

(Fig.22)

Applications

Memory back-up for general equipment (DVD, TV, stereo, etc.).

3-2-4 HW series

Basic Construction

The **HW** Series are constructed from activated carbon particles, mixed with a binder then deposited on aluminum foil strips. Lead wires are then connected. The foil strips are wound together with a separator and inserted into aluminum case. Electrolyte is then added, the case is sealed with a rubber packing and finally sleeved (Fig.23).

Features

The **HW** series was developed for use in applications requiring large amounts of current. Its internal resistance is less than 1/100 of general products. Applications of Gold capacitor range from memory back-up to motor driving. For example, the motor can work over 3 minutes with charging time of a few seconds. It can be charged/discharged over 100 thousand times, making the Gold Capacitor suitable for applications like toys, LEDs, etc.

Applications

1. Solar battery circuits (Road guidance flasher, LED light)
2. Toys (Motor-drive)

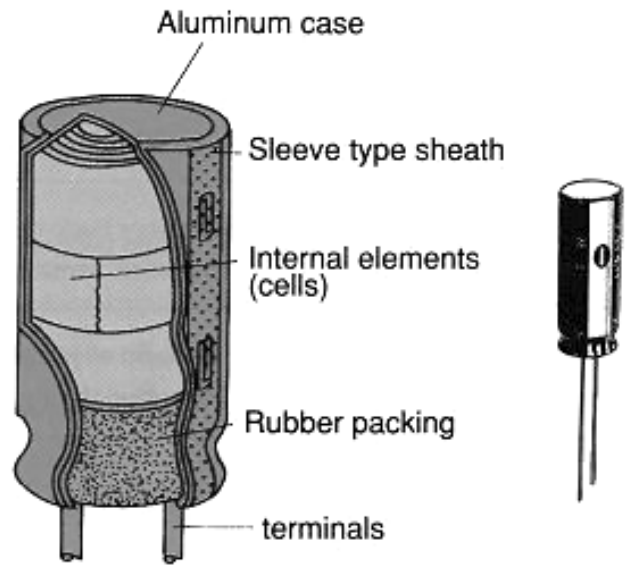











AL series construction

(Fig.23)

3-3 Applications and Recommended Series

Typical Applications and recommended series

Application		Recommended Series	Component
Mobile Phone	Real-Time Clock Back-up	EN	
PDA	Real-Time Clock Back-up		
DSC	Real-Time Clock Back-up	EN, SD	
DVD Recorder	Real-Time Clock and Channel Back-up	SD, SG	
Digital TV	Real-Time Clock and Channel Back-up	SD, SG, NF	
PC, Server	Real-Time Clock and Channel Back-up	F	
Mobile Phone Base Station	Real-Time Clock and Channel Back-up		
Inkjet Printer	For the Time of Intact Back-up	SD, SE, SG, NF	
Electric Power, Gas, Water Meter	Real-Time Clock and Data Back-up	F	
LED Light with Solar Battery	LED Lighting at Night	HW	
Toy (Motor Drive)	Motor Drive		
Toy (Portable Game)	Real-Time Clock Back-up	EN	
FA, Robot, IPC	Real-Time Clock and Data Back-up	F	
Car Audio (Memory)	Real-Time Clock Back-up		
Car Audio (HDD drive)	HDD Drive Back-up	HW	

3-4 How to Select a Gold Capacitor

3-4-1 Estimated initial back-up time

Back-up time for Gold capacitors decrease with use and over time. Especially, when the applied current is large or operating conditions are severe (e.g. high temperature).

Initial back-up time should be considered with enough margins.

Avoid setting the minimum back-up time. (Refer the life design for details)

3-4-2 Select the optimum Gold capacitor according to applied Current

Where the applied current to a Gold capacitor is large, flash voltage drop (IR drop) may occur when changing to back-up mode. Therefore, the product should be selected according to operating applied current. The amount of applied current (discharge current) has different resistance values vs. product type.

Recommend currents are shown below. (Please contact local technical support when the applied current used is beyond the recommended range.)

Series	Maximum operating (discharge) Current				
	0.047F	0.1 to 0.33F	0.47 to 1.5F	3.3 to 4.7F	10F to 50F
SG, SD, SE, NF	200 μ A	300 μ A	1mA	—	—
F	200 μ A	300 μ A	300 μ A	—	—
EL	—	300 μ A	1mA	—	—
EN	—	10 μ A	—	—	—
HW	—	—	100mA	300mA	1A

Operating Techniques of Gold Capacitors

4-1 Life design

4-1-1 Useful life

Gold capacitors have a useful life-time similar to that of aluminum electrolytic capacitors. The life of a Gold Capacitor is largely dependent on the operating temperature, humidity, applied voltage, current and backup time requirements. Therefore, the life of a Gold Capacitor is determined based on the back-up time set by the customer.

4-1-2 Example of expected life

An example of an expected life-time of a Gold Capacitor is shown as follows:

$$\text{Expected life} = \text{Life-time} \times \text{Temperature factor} \times \text{Voltage factor} \times \text{Moisture factor}$$

Note: Life-time is defined as the time it takes to reach back-up time set by the customer after applying the rated maximum temperature and rated voltage to the capacitor.

Example: An F type Gold capacitor, P/N: EECF5R5H105 (Rated at 5.5V, 1.0F), is fully charged at 5.0V D.C. The circuit requirement is such that it must maintain a memory circuit with a current drain of 10 μ A in an ambient temperature of +40°C. The memory RTC cut-off voltage is 2.0V D.C.

The back-up time can be calculated from the following equation.

$$t = CV/i = C \times (V_0 - iR - V_1) / (i + i_L)$$

$$C = 0.8F (1.0F - 20\%), R = 50\Omega, V_0 = 5V, V_1 = 2V, i = 10\mu A$$

Therefore,

$$t = 0.8 \times (5 - 0.0005 \times 2) / (10 + 2 \times 10^{-6}) = 55 \text{ hours}$$

t: Back-up time (s)

C: Capacitance of Gold capacitor (F)

V₀: Applied voltage (V)

V₁: Cut-off voltage (V)

i: Current during back-up (A)

i_L: Leakage current (A)

R: Internal resistance (Ω) at 1 kHz

This calculation shows the initial back-up time to be 55 hours.

Product Life

The guaranteed life is 1000 hours for -30% capacitance change, 4 times the internal resistance change at 85°C with 5.5VDC applied. After 1000 hours, the back-up time will be changed to approximately 38 hours.

Temperature factor

To determine the serviceable life of a Gold Capacitor, one can use the *Arrhenius Equation*, which states that the life will double for every 10°C reduction in ambient temperature.

$$2^{(85-40)/10} = 2^{4.5} = 22.6$$

Voltage factor

The capacitance rate of change for each applied voltage becomes smaller when the applied voltage becomes lower. The time to reach the same change rate at 5V will be 1.1 times longer than 5.5V.

Expected life

The expected life is calculated as follows:

$$\begin{aligned} \text{Expected life} &= \text{Guaranteed life} \times \text{Temperature factor} \times \text{Voltage factor} \\ &= 1000(\text{h}) \times 22.6 \times 1.1 = 24800(\text{h}) = 2.8\text{years} \end{aligned}$$

The back-up time is about 38 hours.

Humidity factor

The life-time of Gold Capacitors is largely dependent on humidity. If a Gold Capacitor is to be used in high humidity conditions, please contact your local technical representative for assistance.

These calculation results are for reference only. They are not guaranteed values.
Please carefully review your design parameters prior to implementation.

4-2 Notes on using Electric Double Layer Capacitors

4-2-1 Notice

1. Life-time

Gold capacitors have a longer life than secondary batteries, although limited. During use, capacitance decreases and internal resistance increases. Taking into consideration sufficient back-up time when designing the circuit, the life-time of a Gold Capacitor is greatly affected by ambient temperature, applied voltage and operating currents. By reducing these factors as much as possible, capacitor life-time can be lengthened. Using products beyond life-time may change characteristics rapidly, and may cause a short-circuit, trigger the pressure relief vent, or cause the electrolyte to leak.

2. Residual electric charge

Since Gold capacitors can hold a substantial charge, there may be residual electric charge built up that could damage other low-withstanding voltage parts such as semiconductors.

3. Ambient temperature and humidity

- Capacitor life is affected by operating temperature. In general, lowering ambient temperature by 10°C will double the life of a capacitor. Use the capacitor at the lowest possible temperature within the maximum operating temperature.
- Operation above the specified maximum temperature not only shortens capacitor life, but also causes serious damage such as electrolyte leakage. Verify the operating temperature of the capacitor by taking into consideration not only the ambient and internal temperature, but also thermal radiation from heat generating elements inside the unit (power transistor, IC's, resistors, etc.) and self-heating due to ripple currents. Be careful not to place heat-generating elements across from the capacitor on the opposite side of the PCB.
- Capacitor life is affected by ambient humidity. Product life is considerably shortened when using Gold capacitors in the high humidity conditions.

4. Voltage drop during back-up operation

Take careful note of the voltage drop caused by the instantaneous operating current and the internal resistance of the Gold Capacitor when switching from power - failure - detection to back-up mode. Because internal resistance varies by product, use the following table to decide the correct operating (discharge) current.

Series	Maximum operating (discharge) Current				
	0.047F	0.1 to 0.33F	0.47 to 1.5F	3.3 to 4.7F	10F to 50F
SG, SD, SE, NF	200μA	300μA	1mA	—	—
F	200μA	300μA	300μA	—	—
EL	—	300μA	1mA	—	—
EN	—	10μA	—	—	—
HW	—	—	100mA	300mA	1A

5. External sleeve

External sleeve is not intended to ensure electrical insulation, therefore, capacitors should not be used in an environment that requires electrical insulation.

6. Heat stress during soldering

Excessive heat stress may result in the deterioration of the electrical characteristics of the capacitor, loss of vacuum, and electrolyte leakage due to the rise in internal pressure.

- If the tip of the soldering iron touches the capacitor's external sleeve, the sleeve will melt or rupture.
- Use the general reference charts to set soldering temperature versus time.

Flow Soldering

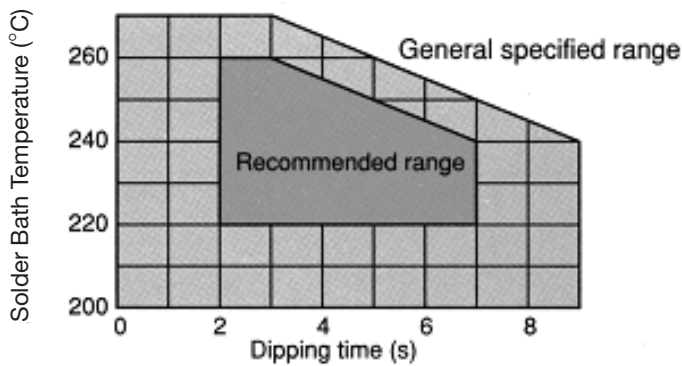

Pre-heating temperature : 110°C or under (on the surface of circuit board)
 100°C or under (on the surface of capacitor)
 Pre-heating time : 60 seconds or under
 Board thickness : 0.8 mm or more

Re-Flow Soldering (Only EN-series 250°C high temp. type)

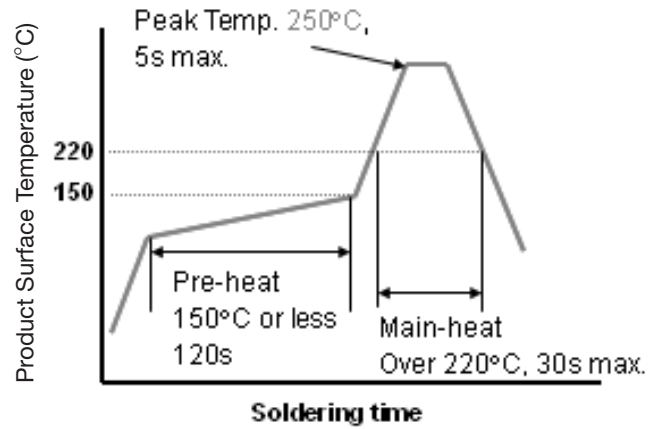

Reflow profile at 250°C.

7. Brown extraction

Brown extraction may occur around the sealing part depending on use conditions. This extraction is electrically non-conductive. Therefore, it does not influence in the electric characteristics.

4-2-2 Caution

1. This specification guarantees the quality and performance of the product as individual components. Before use, check and evaluate their compatibility when installed in your products.
2. Do not use the products beyond the specifications described in this document.
3. Electrolyte leakage: Electrolyte is used in the product. Misuse can result in rapid deterioration of characteristics and its functionality. Electrolyte leakages damage printed circuit and affects performance, characteristics, and functions of the circuit.
4. Over Voltage: If Gold Capacitor is used at a voltage exceeding its maximum operating voltage, not only is its life shortened but it may cause capacitor to leak or rupture.
5. Polarity: Be sure to verify the polarity of the capacitor before use. If a reverse voltage is applied for a long period of time, capacitor life is shortened and serious damage such as electrolyte leakage may occur.
6. Ripple current: Gold Capacitors have a higher internal resistance than electrolytic capacitors and are more susceptible to internal heat generation. As the temperature of the element rises, additional current flows inside the Gold Capacitor, raising the internal resistance even further. This makes it difficult to maintain the capacitor temperature at 3°C (measured at the surface of the capacitor).

7. Connecting Capacitors in Series: Taking into consideration the possibility of an imbalance of voltage across the capacitors, one needs to make sure that the voltage applied to each capacitor will not exceed the maximum operating voltage.

If the voltage balance breaks down, an over voltage condition may result. To prevent this from occurring, add a voltage-driving resistor in parallel with each capacitor, allowing the capacitor's leakage current.

8. Environmental conditions: Avoid the use of capacitors at temperatures above the maximum operating temperature. In this case, it may increase pressure to electrolyte vapor and release of gas by electrochemical reactions. This will also result in a rise of its inner-pressure, which may cause electrolyte to leak and seriously damage the capacitor.

9. Mounting considerations:

A) Double-side circuit board: Do not set wiring pattern directly to the mounted capacitor, and pass between terminals. If the electrolyte leaks, short circuit may occur and "tracking or migrations" are anticipated.

B) Through hole board: Do not locate the capacitor close to circuit board. Solder blowing out of the holes may cause a short circuit.

10. Do not apply any strong pressure to the capacitor after installation has been completed.

11. Do not use glue that contains halogen.

12. Circuit board cleaning: Circuit boards can be immersed or ultrasonically cleaned using suitable cleaning solvents for up to 5 minutes and up to 60°C maximum temperature. The board should be thoroughly rinsed and dried.

Recommended Cleaning Solvents

Pine Alpha ST-100s, Sunelec B-12, DK be-clear CW-5790, Aqua Cleaner 210SEP, Cold Cleaner P3-375, Cclear-th-ru 750H, Clean-thru 750L, Clean-thru 710M, Techno Cleaner219, Techno Care FRW-17, Techno Care FRW-1, Techno Care FRV1

- Please consult your local technical representative if you are using a solvent other than the ones listed above.
- The use of ozone depleting cleaning agents are not recommended in the interest protecting the environment.

13. Failsafe design: Install the following protection systems for a failsafe design to ensure safety if these products are to be used in equipment where a defect in these products may cause the loss of human life or other significant damage, such as damage to vehicles (automobile, train, vessel, etc.), traffic lights, medical equipment, aerospace equipment, electric heating appliances, combustion/gas equipment, rotating equipment, and disaster/crime prevention equipment.

- A protection circuit and protection device.
- A redundant circuit or other system to prevent an unsafe status in the event of a single fault.
- Please check or replace the Gold Capacitor periodically.

14. Before using the products, carefully check the effects on their quality and performance, and determine whether or not they can be used. These products are designed and manufactured for general-purpose and standard use in general electronic equipment. These products are not intended for use in the following special conditions.

- In liquid, such as water, oil, chemicals, or organic solvent
- In direct sunlight, outdoors, or in dust
- In vapor, such as dew condensation water of resistive element, or water leakage, salty air, or air with a high concentration corrosive gas, such as Cl₂, H₂S, NH₃, SO₂, or NO₂
- In an environment where strong static electricity or electromagnetic waves exist
- Mounting or placing heat-generating components or inflammables, such as vinyl-coated wires, near these products
- Sealing or coating of these products or a printed circuit board on which these products are mounted, with resin and other material
- Using solvent, water or water-soluble cleaner for flux cleaning agent after soldering.
(In particular, when using water or a water-soluble cleaning agent, be careful not to leave water residue)

15. Please arrange circuit design for preventing impulse or transitional voltage. Do not apply voltage, which exceeds the full rated voltage when the capacitors receive impulse voltage, instantaneous high voltage, high pulse voltage etc.

16. Do not store capacitor under any of the environment conditions listed below.

- At high temperature and high humidity.
- Where the capacitor is in contact with water, salt water or oil.
- Where the capacitor is exposed to direct sunlight or to toxic gases.
- Where there is a lot of dust in the air.

17. Emergency procedures: If capacitors overheat or start to emit an odor, immediately switch off the unit's main power supply to stop operation. Keep your face and hands away from the capacitor, since the temperature may be high enough to cause the capacitor to ignite and burn.

18. Capacitors disposal: When disposing of capacitors, follow the instructions below.

- Crush or make a hole in the capacitor before burning. If the capacitor is burned without making a hole, it can explode. If taking apart the capacitor before disposal, wear protective gear such as gloves and goggles.
- If you choose not to burn used capacitors, consign them to a specialized industrial waste processor for disposal.

19. Heat at curing adhesives for chip components: Applying high temperature to Gold Capacitor for a long time may cause poor reliability, even cause initial failure. Therefore, heat curing adhesives should be low temperature and short in duration. An allowable condition is as follows:

For coin type (EL) and multi-layer type (SG, SD, NF, F, SE) Gold Capacitors, surface temperature should be 100°C within 60 seconds. (In this case, peak temperature should be less than 105°C)

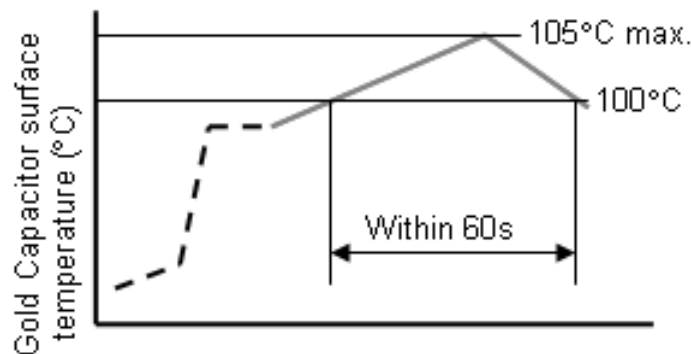

The application guidelines above conform to:

Technical report EIAJ RCR-2370 issued by the Japan Electric Industry Association, Inc. "Guideline of notable for fixed electric double layer capacitors with non-solid electrolyte for use in electric equipment." For further details, please refer to this Technical Report.

4-3 Check List when Ordering Product

When ordering Electric Double Layer Capacitors, please provide the following information:

GOLD CAPACITOR CHECK LIST	
Application	
Charging Conditions	
Charging Voltage	
Charging Time (Max.Min.)	
Charging Current (Balanced Resister, If any)	
Discharging Conditions	
Back Up Current (Max. Min. Typical.)	
Minimum Holding Voltage	
Required Back Up Time	
Back up for xxx (RTC, SRAM Etc.)	
Operating Conditions	
Expected Life	
Ambient Temperature	

Gold Capacitors Characteristics Data

- Charging characteristics
- Self-discharging versus charging time
- Influence of ambient temperature vs. self-discharging
- Discharge characteristics
- Influence of ambient temperature vs. discharging
- Current characteristics
- Relations between discharge current and capacitance change
- Relations between applied voltage and capacitance change
- Relations between ambient temperature and capacitance change
- Reliability and temperature characteristics data

NOTE: The data shown is typical data. It does not guarantee life of product.
Before using the product carefully check the effects on their quality and performance,

Charging Characteristics

Part number: EECS0HD104V (5.5V 0.1F) at +20°C

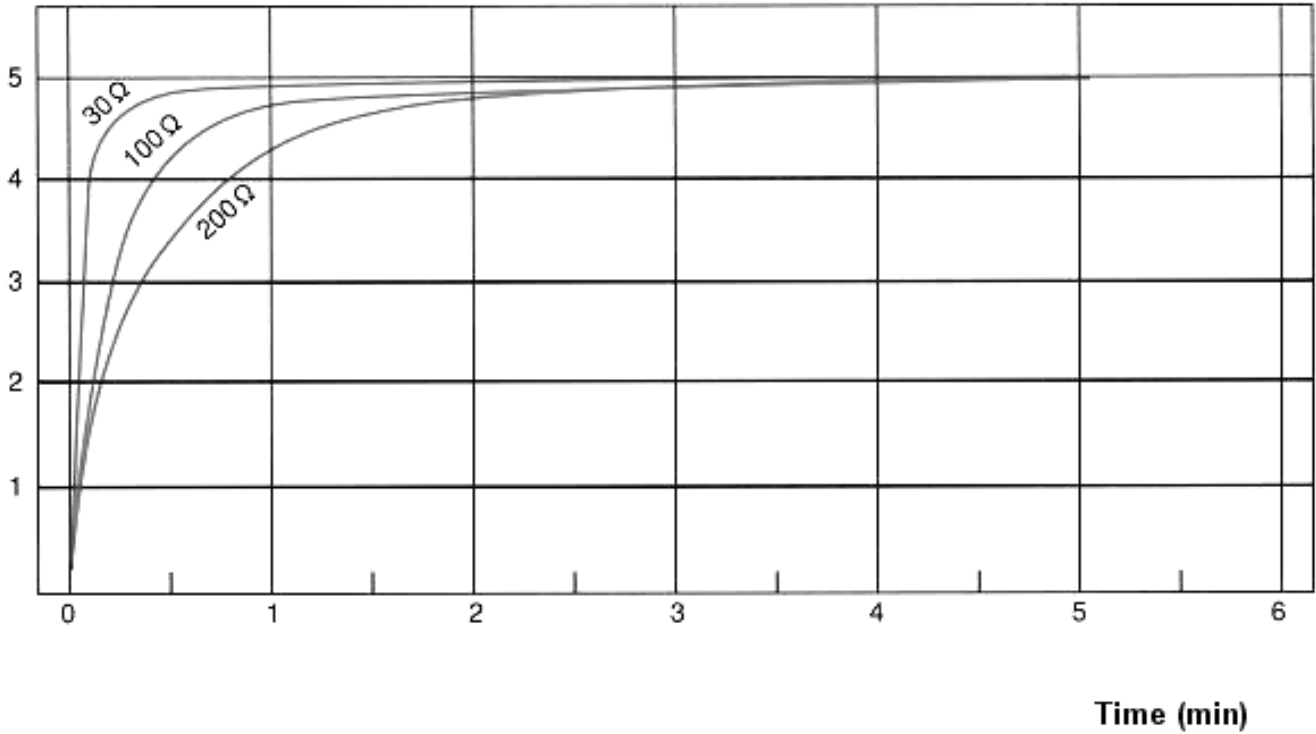

Part number: EECF5R5U105 (5.5V 1.0F) at +20°C

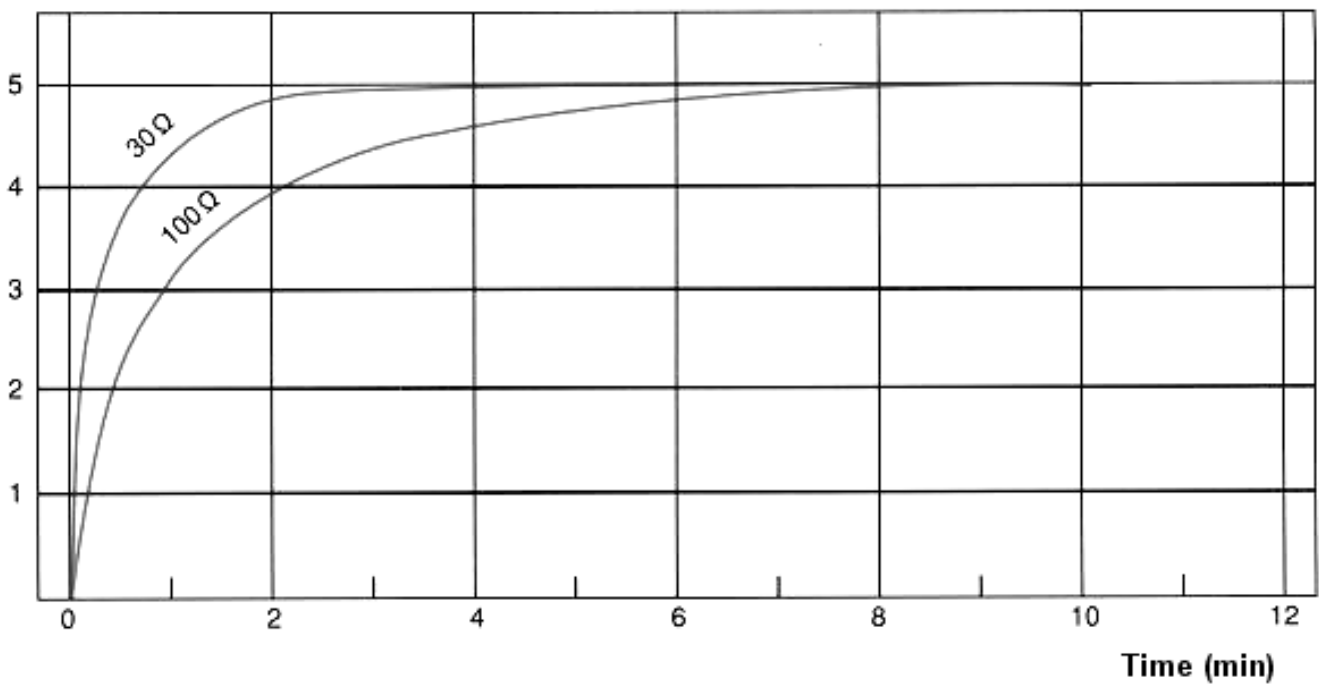

Self-Discharging Characteristics Versus Charging Time

Part number: EECF5R5U105 (5.5V 1.0F) Charge voltage: 5V

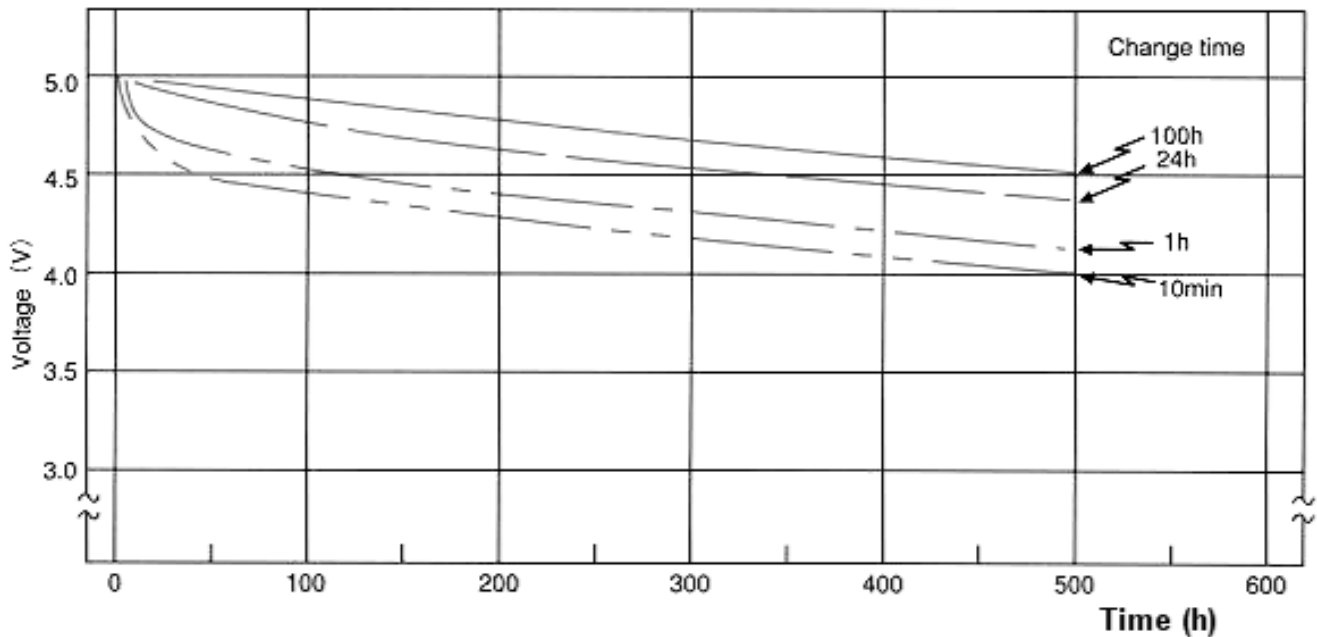

Note: If charging time is brief, complete charge is not attained, and initial voltage due to internal charge is increased.

Influence of Ambient Temperature vs. Self-Discharging

Charging condition: 5V, 24hours

Part number: EECS0HD104V (5.5V 0.1F)

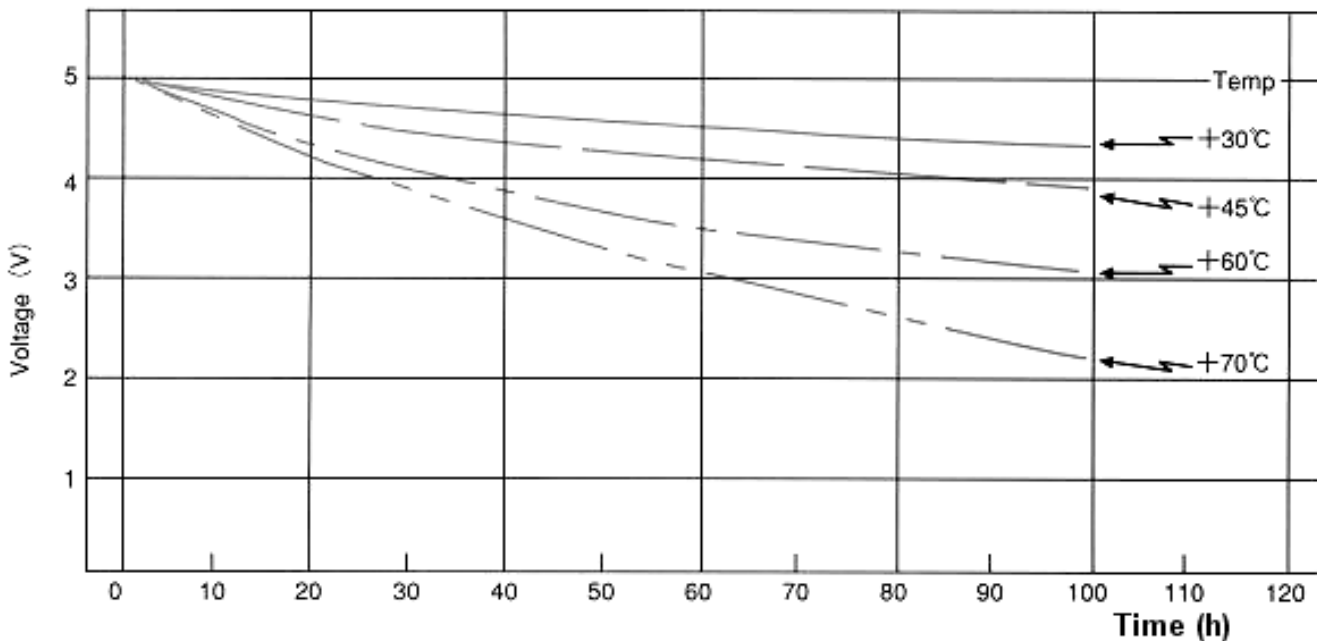

Note: At self-discharge, the terminal voltage drop is affected by ambient temperature. This means the self-discharge current increases as ambient temperature rises. In cases where it is used with a micro applied current of nano-ampere order, ambient temperature allows a difference to occur in back-up time.

Discharge Characteristics

Constant resistance discharge: $1\text{M}\Omega$

Charge voltage: 5V

Charge time: 24hours

Measurement temp: $+20^\circ\text{C}$

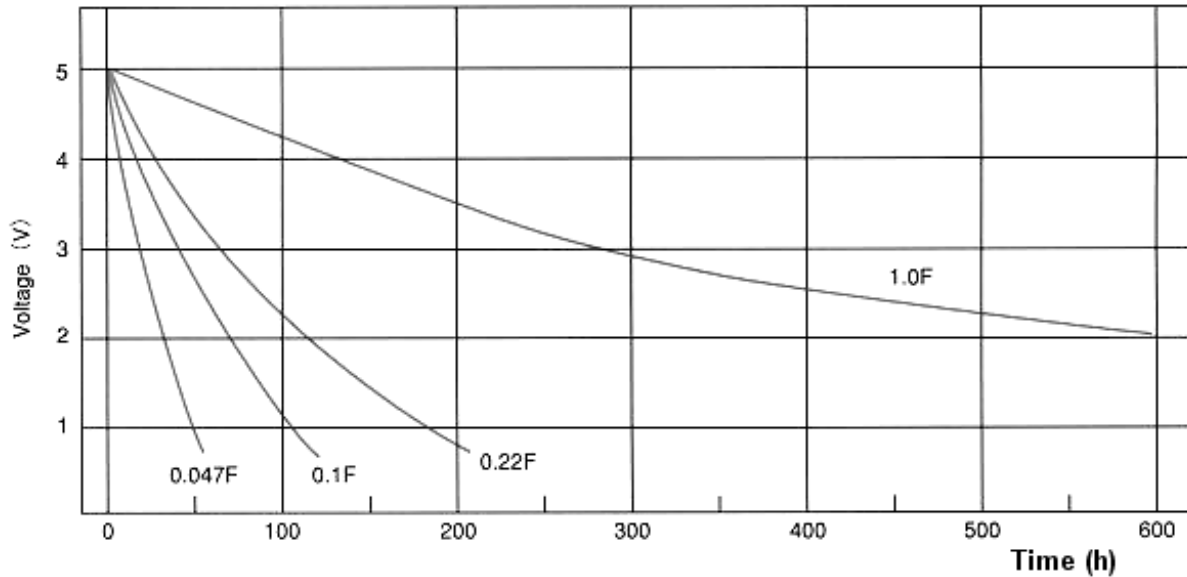

Constant resistance discharge

Charge voltage: 5V

Charge time: 24hours

Part number: EECSoHD473V ($5.5\text{V}0.047\text{F}$)

Measurement temp: $+20^\circ\text{C}$

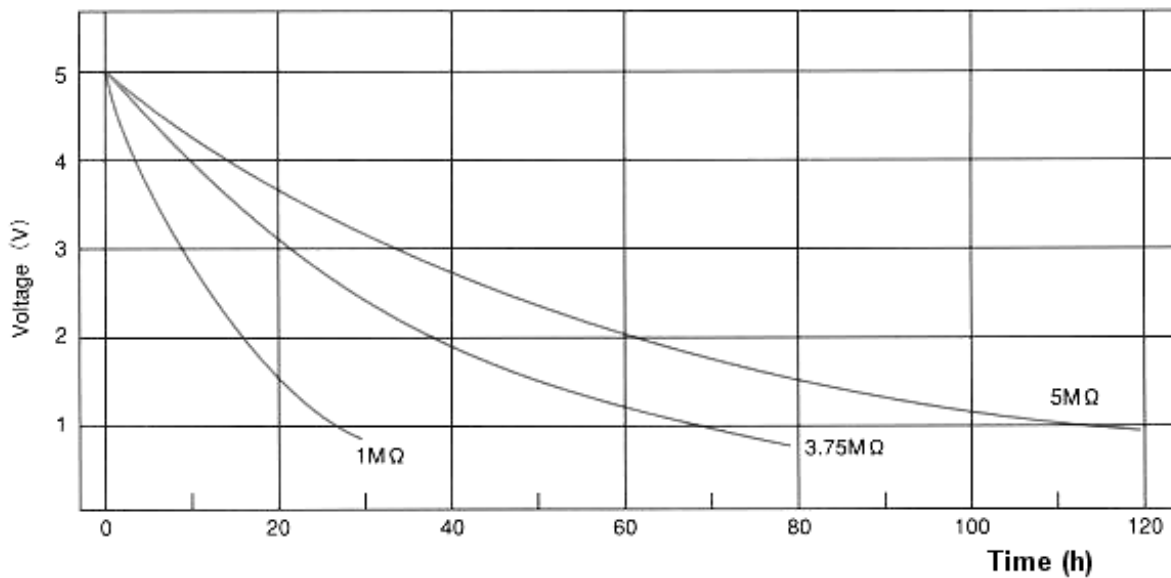

Influence of Ambient Temperature vs. Discharging

Constant resistance discharge: 250kΩ

Charge time: 24hours

Part number: EECF5R5U104 (5.5V0.1F)

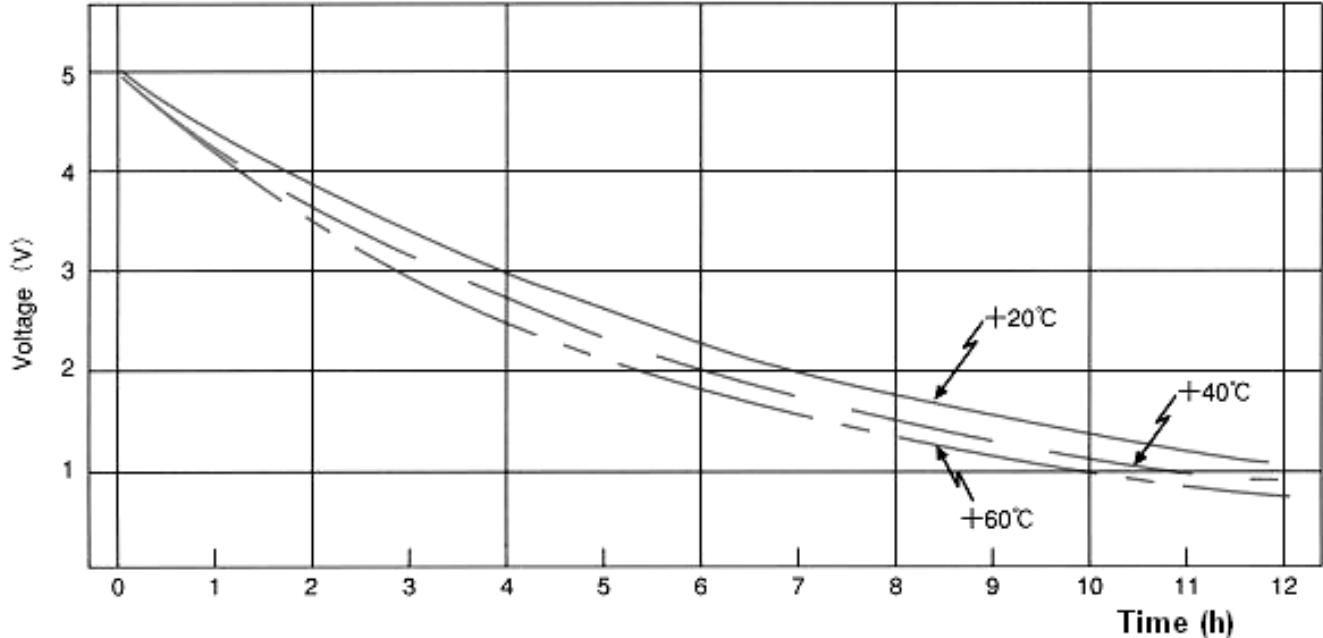

Note: Voltage drops faster as ambient temperature rises. This occurs because the rise in ambient temperature causes a self-discharge current to be added to the applied current.

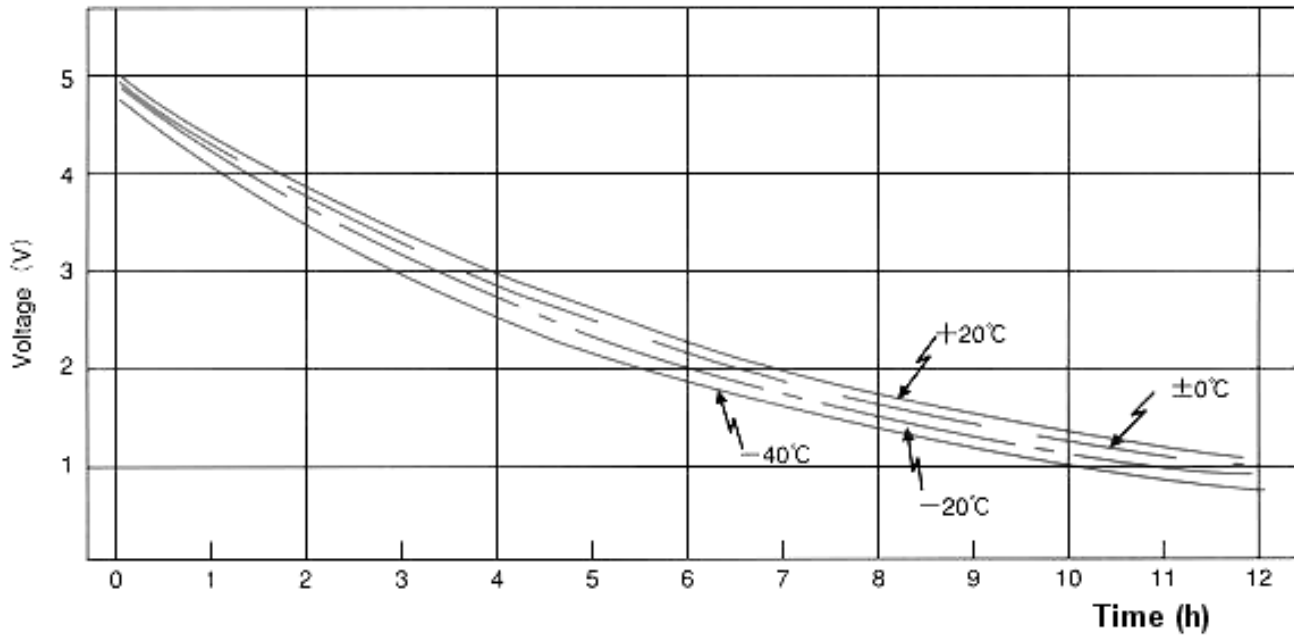

Note: At low temperatures, ion movement for the formation of electric double layers becomes slow and the time required to complete charging is longer. Consequently, in the case where there is no any difference in charging time, the lower the temperature the more the initial voltage drop.

Current Characteristics

Initialization of test samples:

Samples shall be measured after applying 5.5V for 2hours 300Ω resistance (20±10°C, 65±10% not being wetted with dew) and discharging in short circuit condition for 12 to 24hours.

Series NF (n =20)

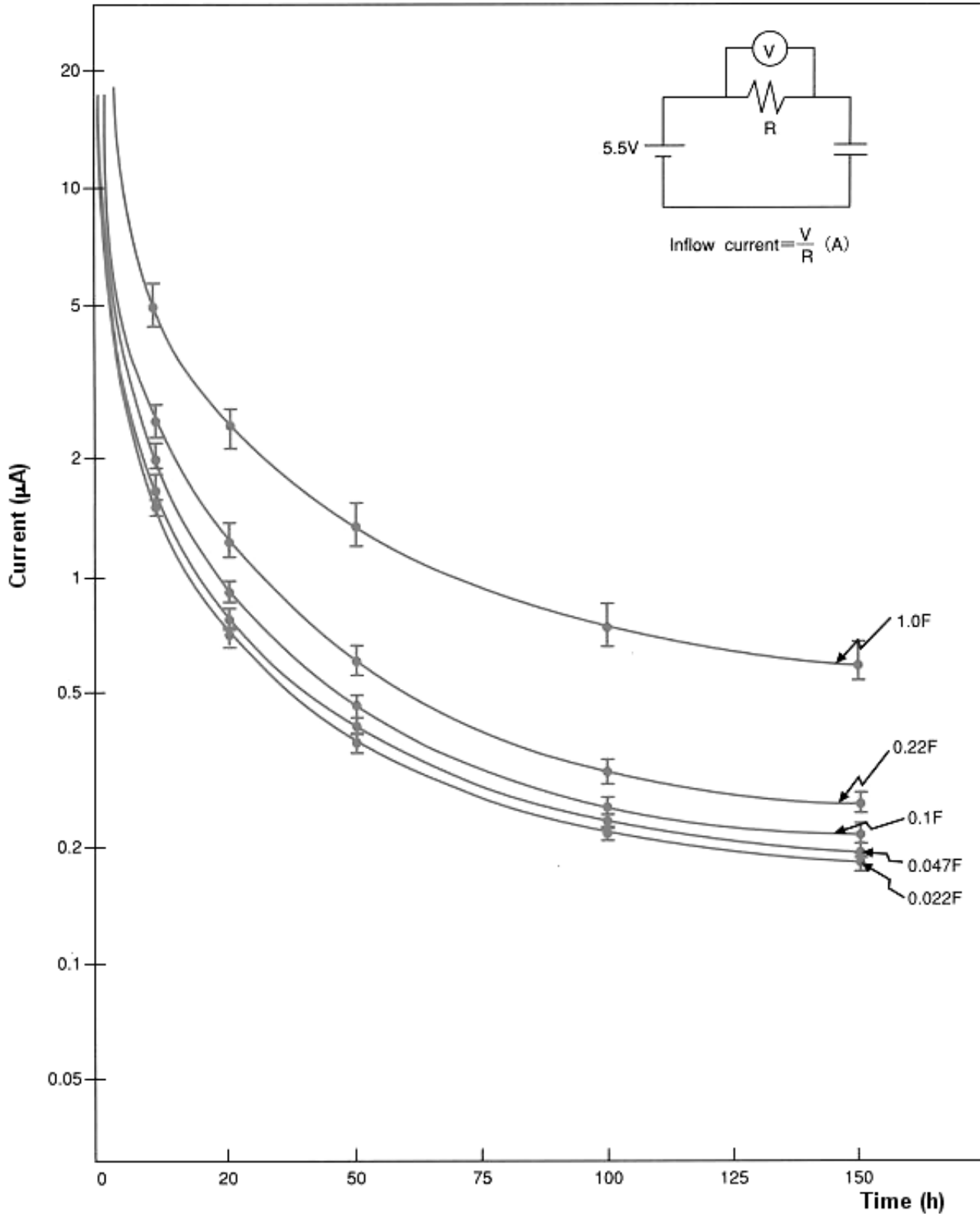

Relationship between Discharge Current and Capacitance Change

Part number: EECF5R5U104 (5.5V0.1F)

Test condition: +70°C 5.5V

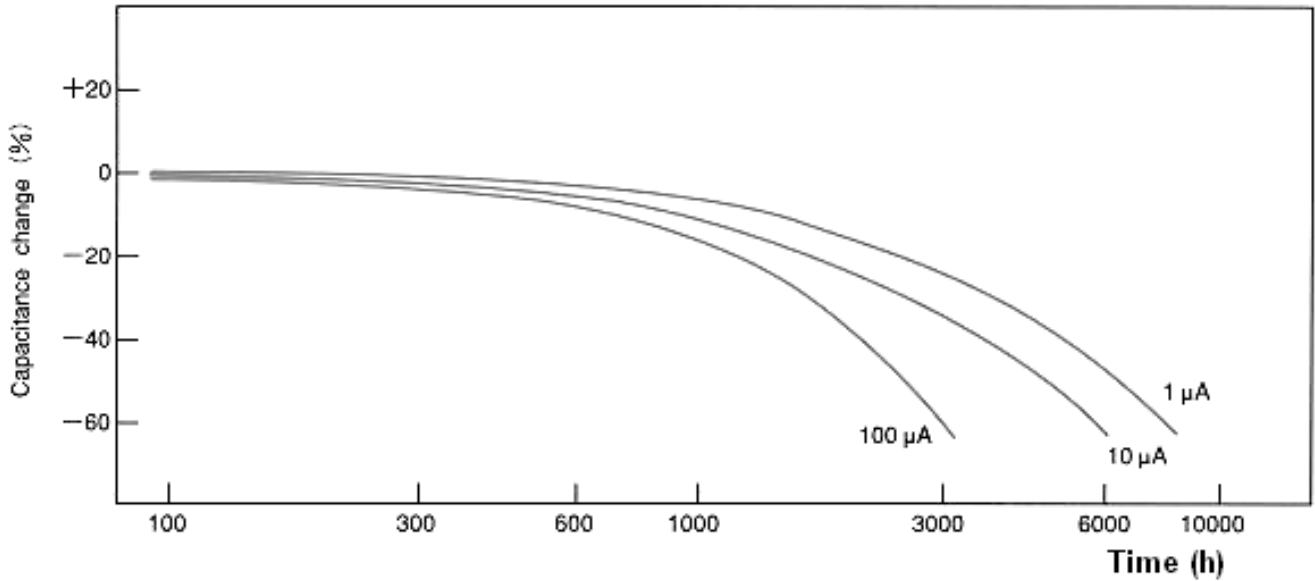

Note: Capacitance changes at life test vary based on applied current (measuring current). The longer the life, the less the applied current.

Relationship between Applied Voltage and Capacitance Change

Part number: EECF5R5U104 (5.5V0.1F)

Test condition: +70°C 5.5V

Applied voltage: 4, 5, 5.5V

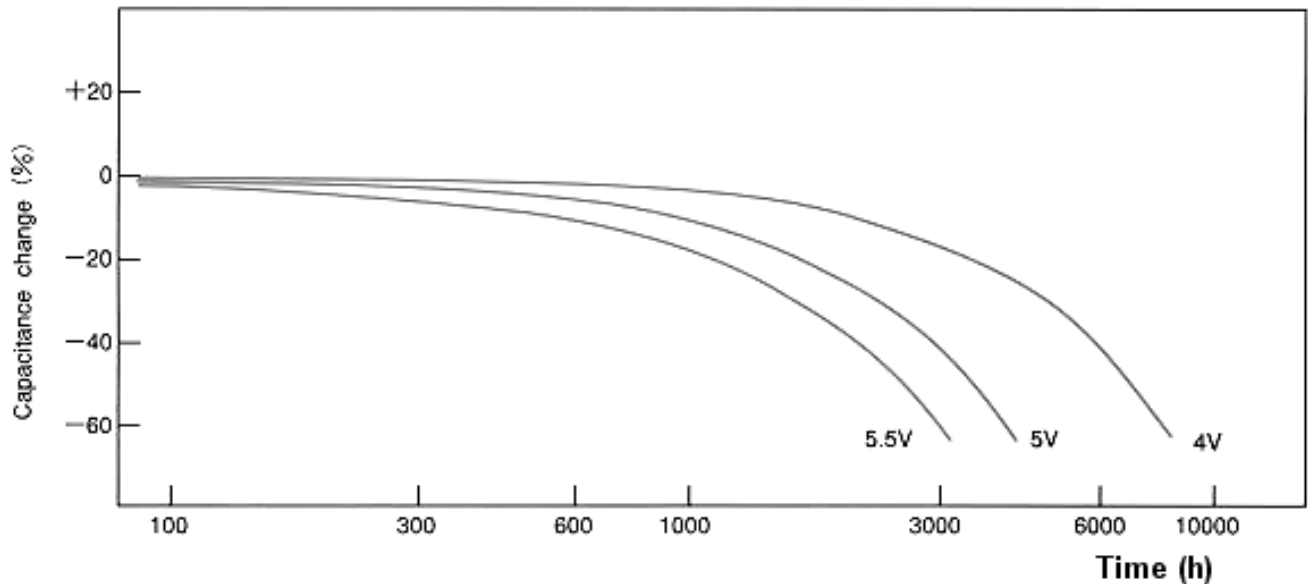

Note: Capacitance changes at the life test vary from applied voltage. The lower the voltage, the smaller capacitance becomes. There is almost no capacitance change due to no-load shelving.

Relationship between Ambient Temperature and Capacitance Change

Part number: EECF5R5U104 (5.5V0.1F)

Test condition: +70, +60, +55°C

Applied voltage: 5.5V

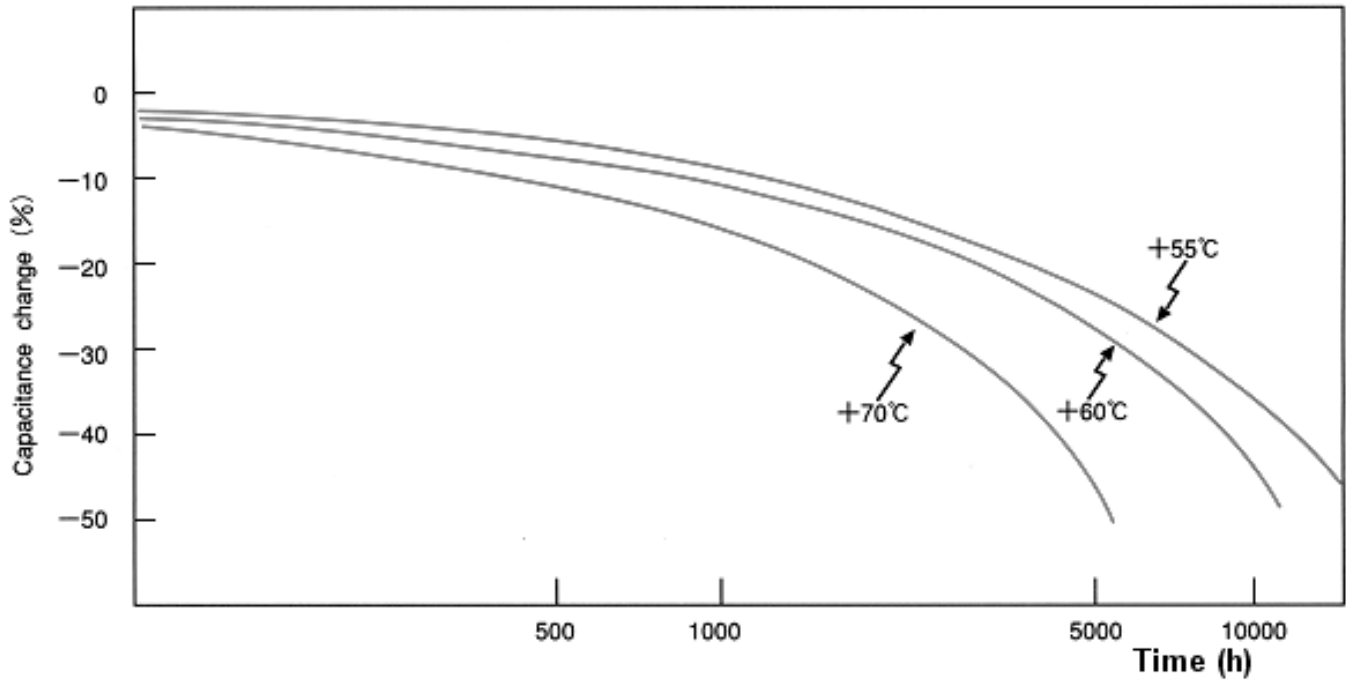

Reliability and Temperature Characteristics Data

Part number: EECF5R5H105 (5.5V, 1.0F)

Endurance (at 85°C, 5.5V applied)

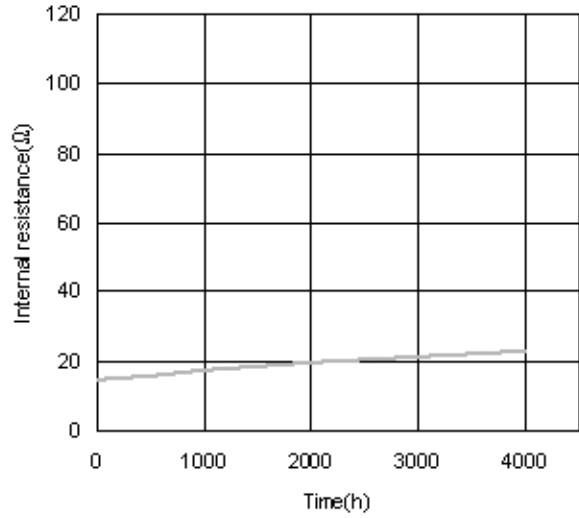
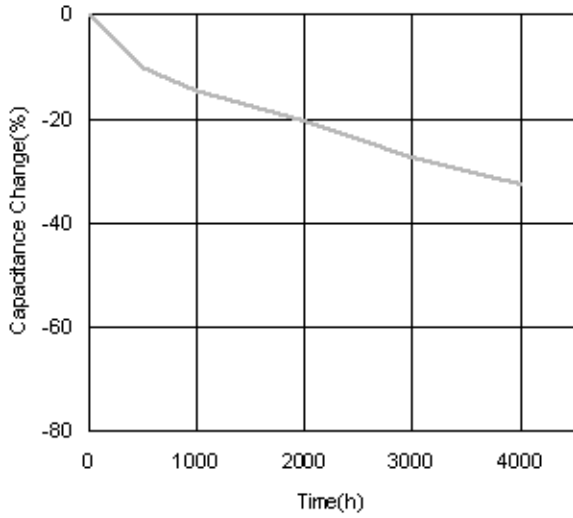

Shelf life (at 85°C)

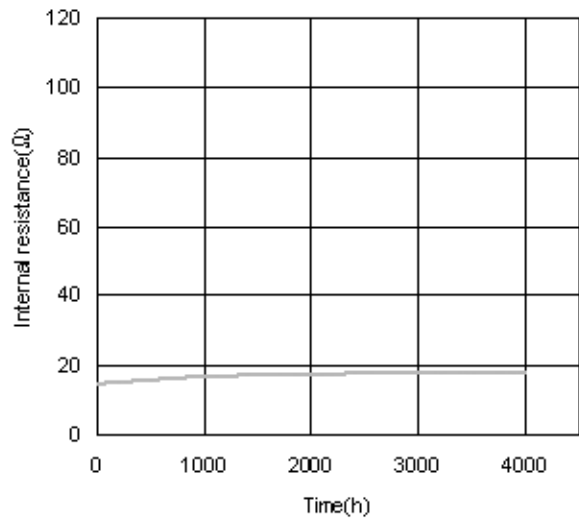
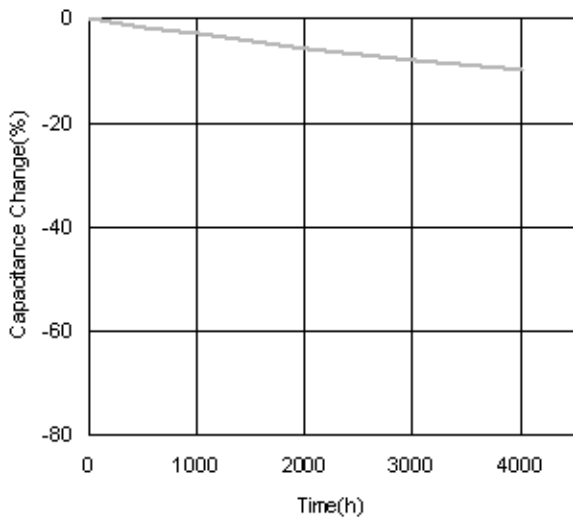

Temperature characteristics

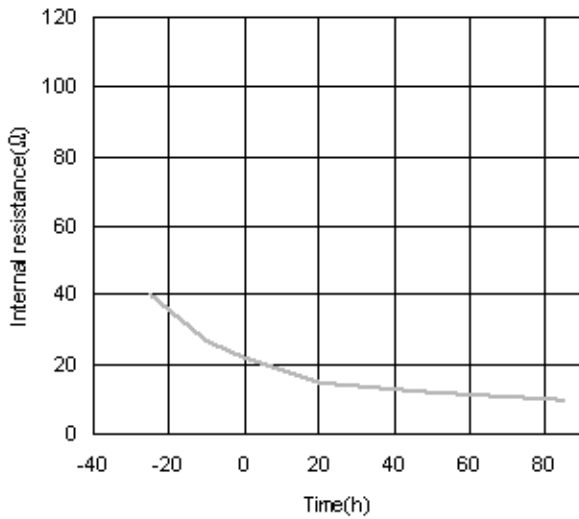
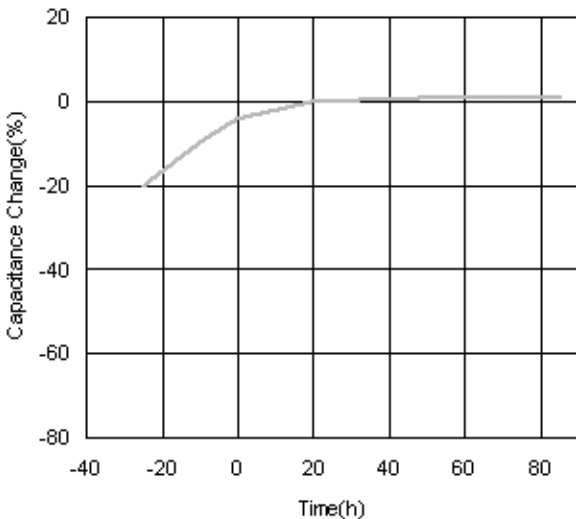

The discharge current shall be calculated by the capacitance value in a ratio of 1mA/F

Part number: EECS0HD224V(5.5V, 0.22F)

Endurance (at 70°C, 5.5V applied)

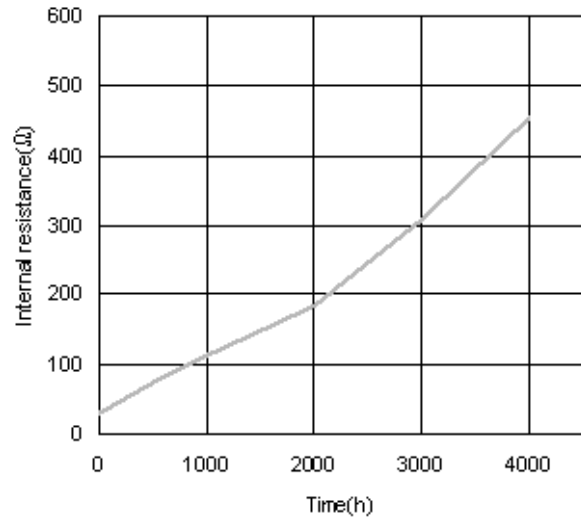
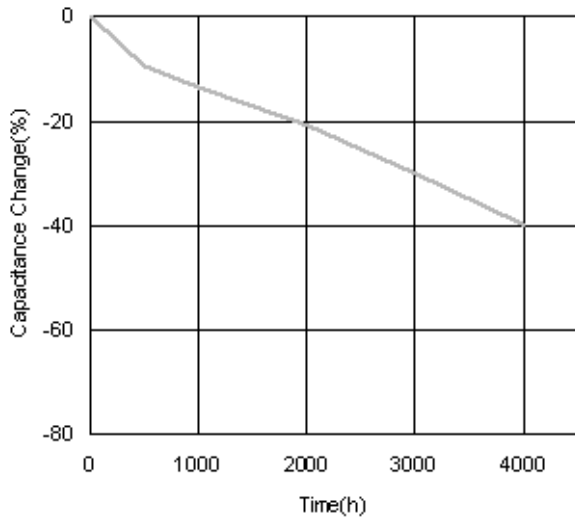

Shelf life (at 70°C)

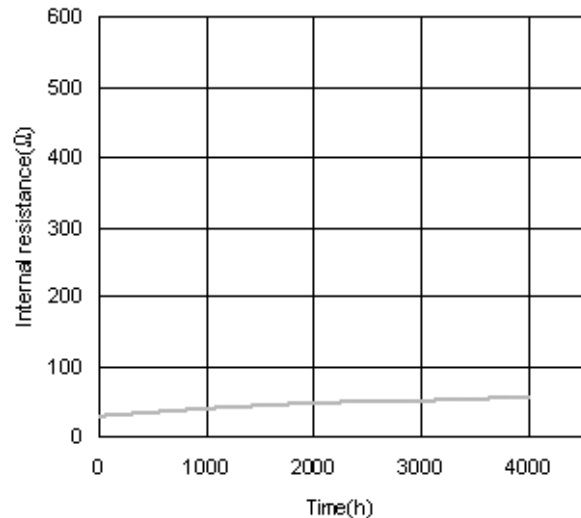
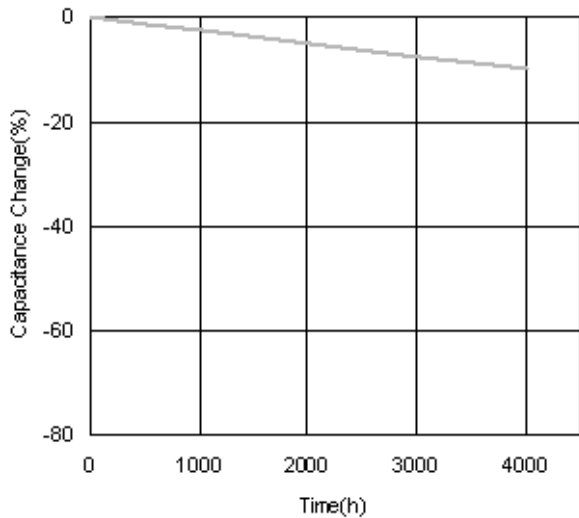

Temperature characteristics

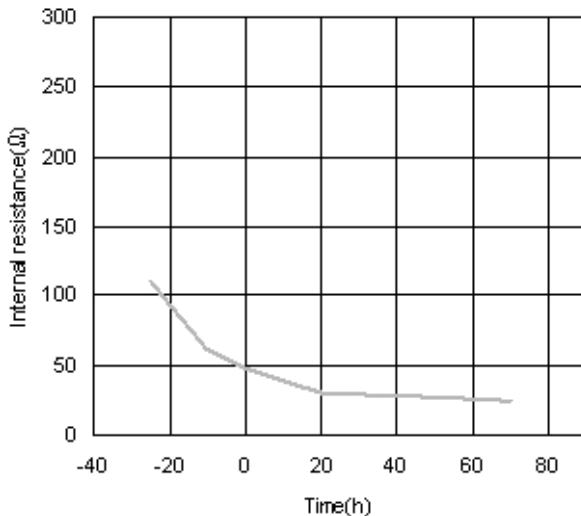
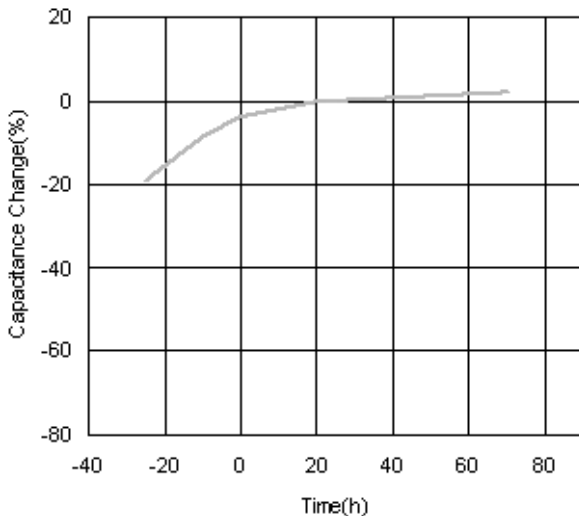

(The discharge current shall be calculated by the capacitance value in a ratio of 1mA/F)

Part number: EECS5R5V155(5.5V, 1.5F)

Endurance (at 70°C, 5.5V applied)

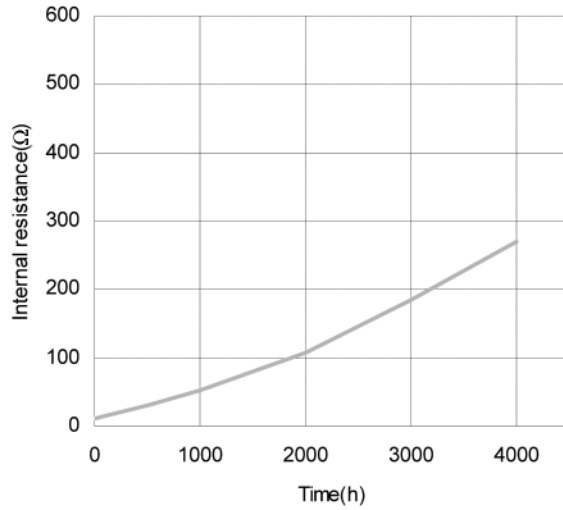
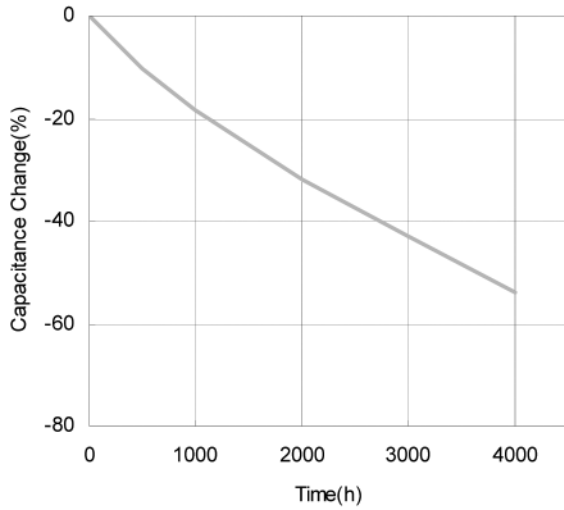

Shelf life (at 70°C)

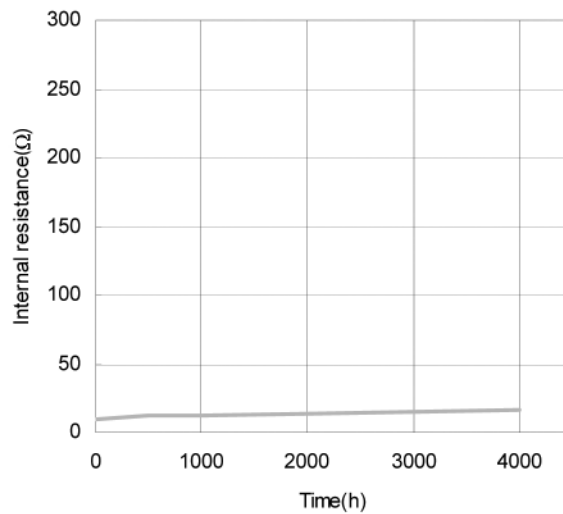
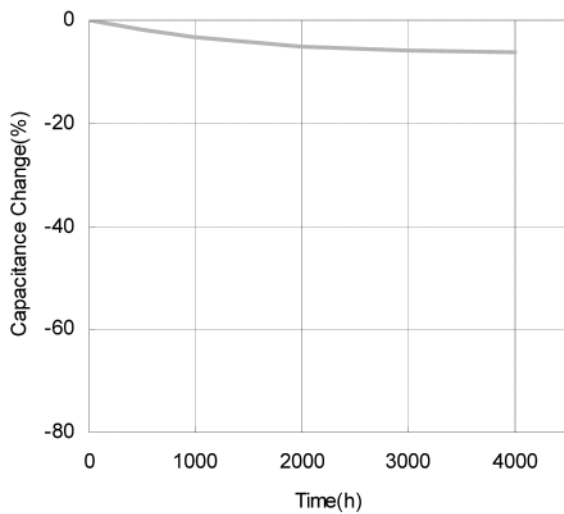

Temperature characteristics

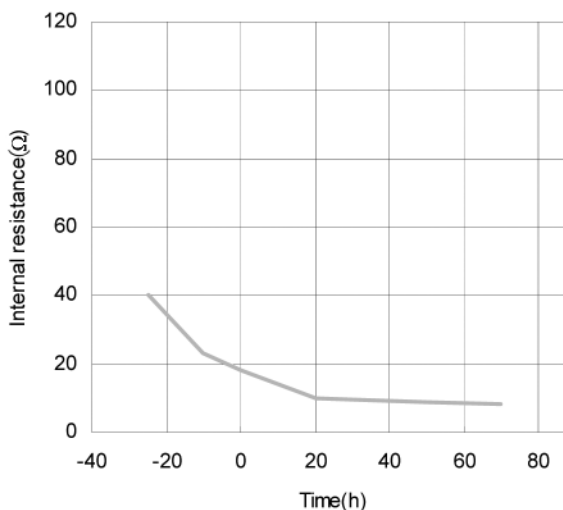
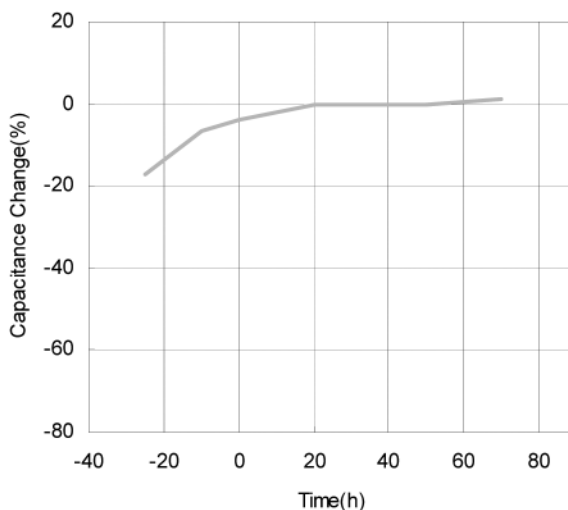

(The discharge current shall be calculated by the capacitance value in a ratio of 1mA/F)

Part number: EECEN0F204A(3.3V, 0.2F)

Endurance (at 60°C, 3.3V applied)

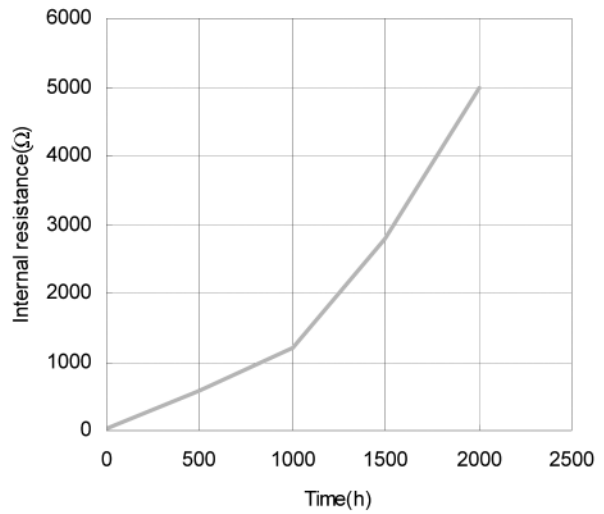
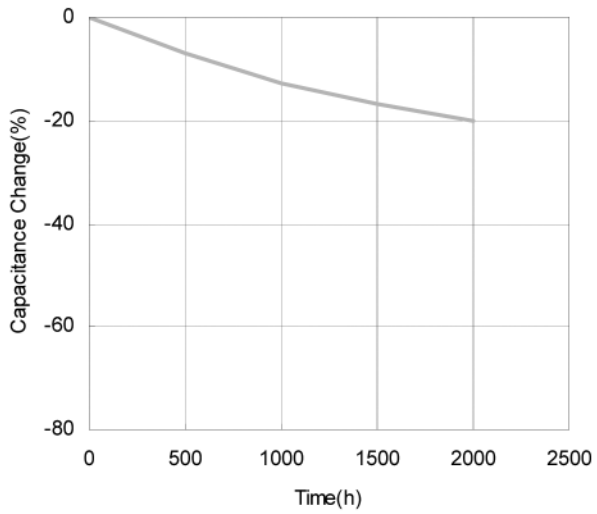

Shelf life (at 60°C)

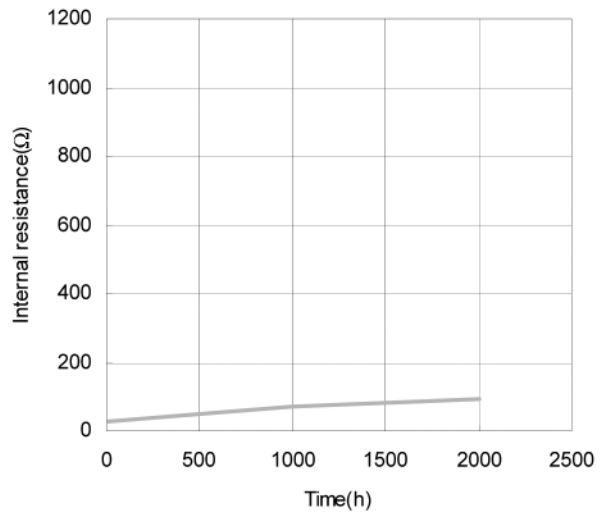
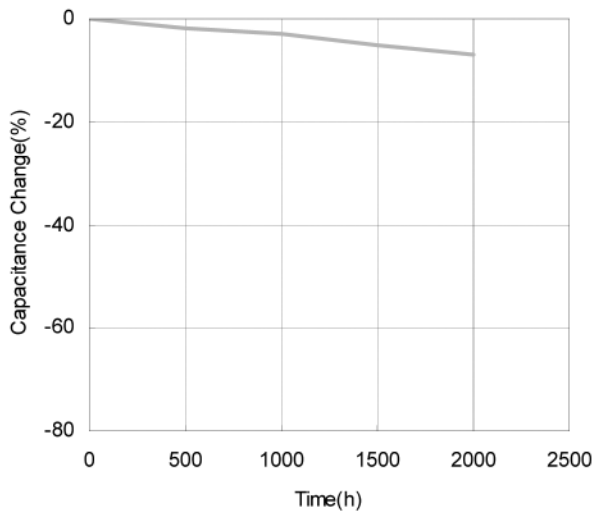

Temperature characteristics

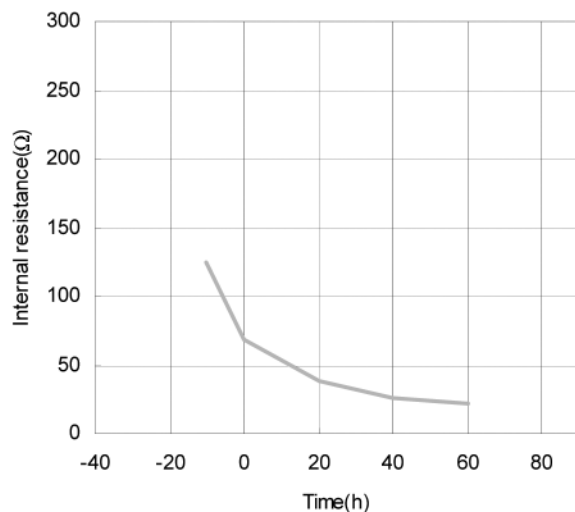
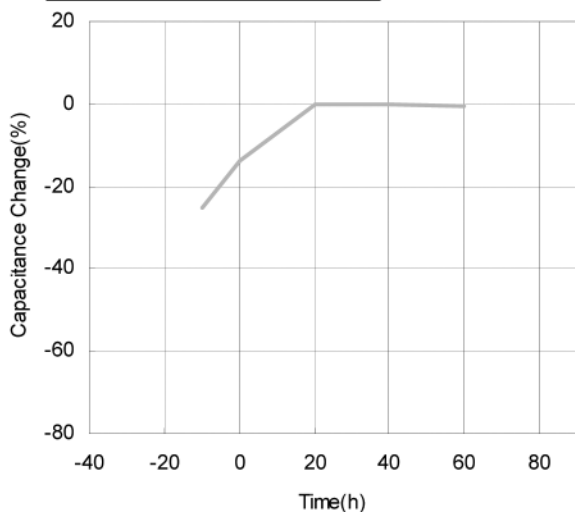

(The discharge current shall be calculated by the capacitance value in a ratio of 1mA/F)

Part number: EECHW0D506(2.3V, 50F)

Endurance (at 60°C, 2.3V applied)

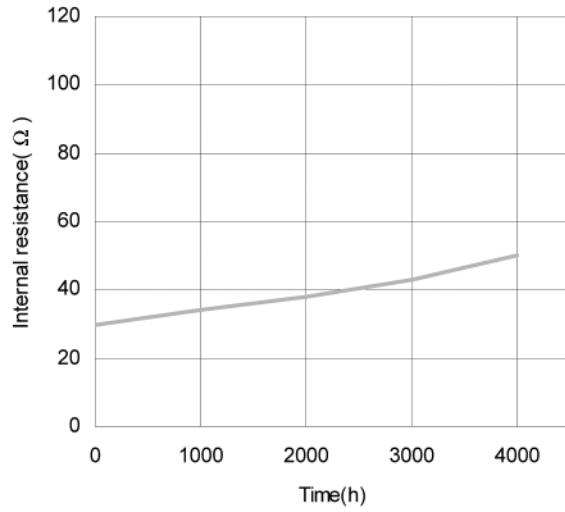
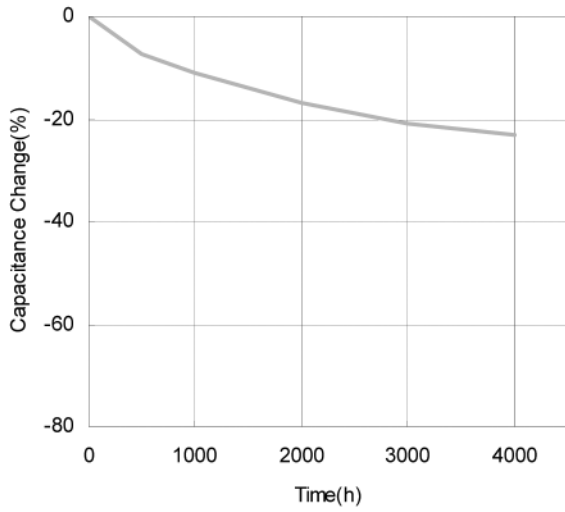

Shelf life (at 60°C)

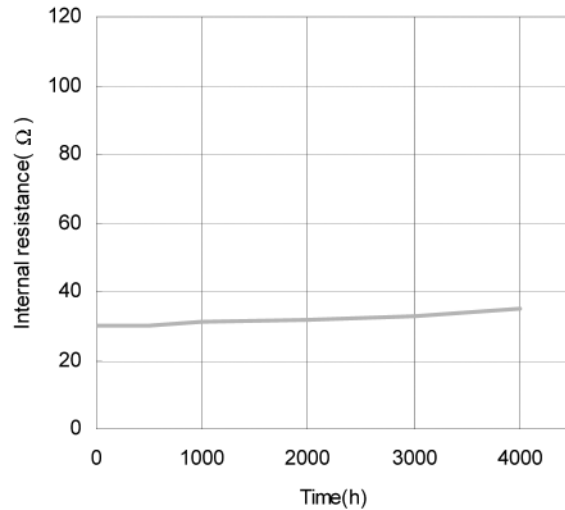
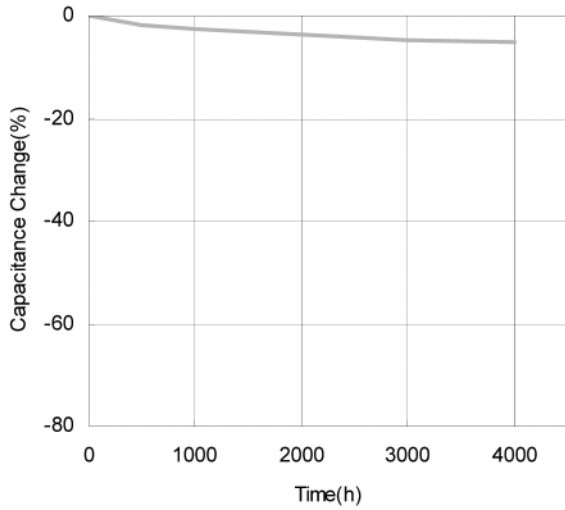

Temperature characteristics

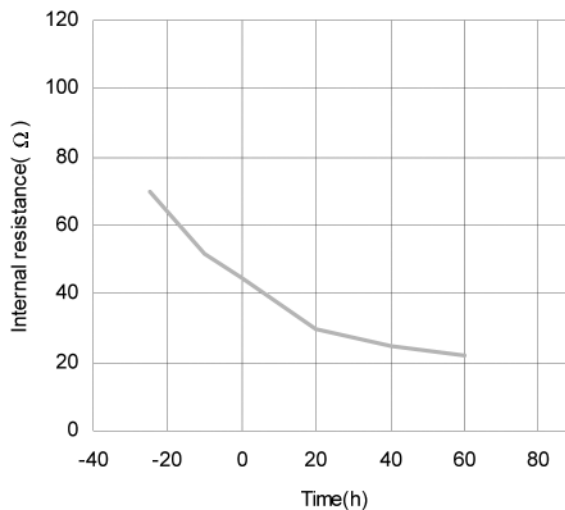
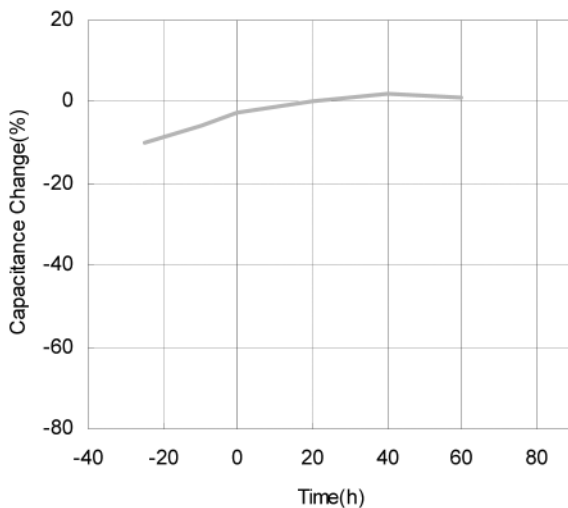

(The discharge current shall be calculated by the capacitance value in a ratio of 1mA/F)

Storage Capabilities of a Gold Capacitor

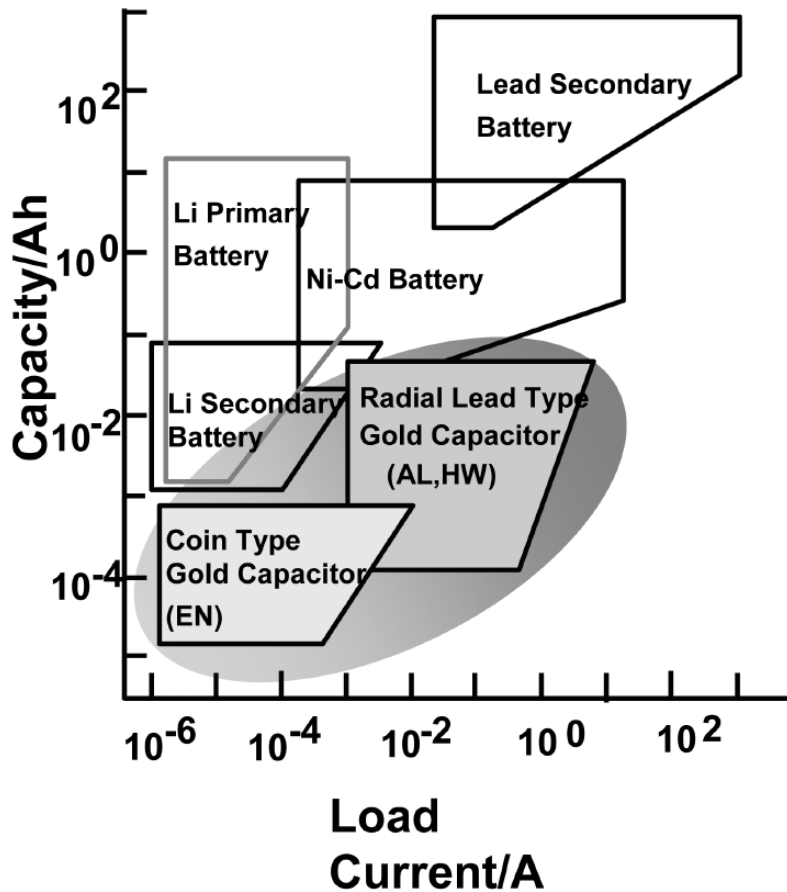

$$T = C (V_0 - V_1) / (I + I_L)$$

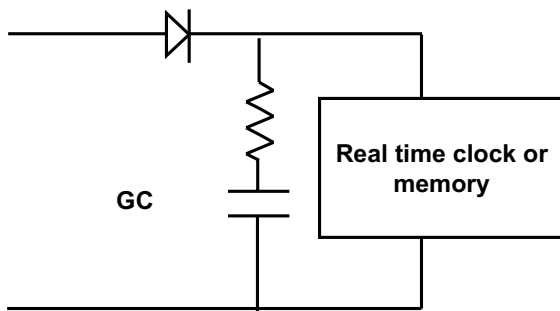

Capacitor's voltage

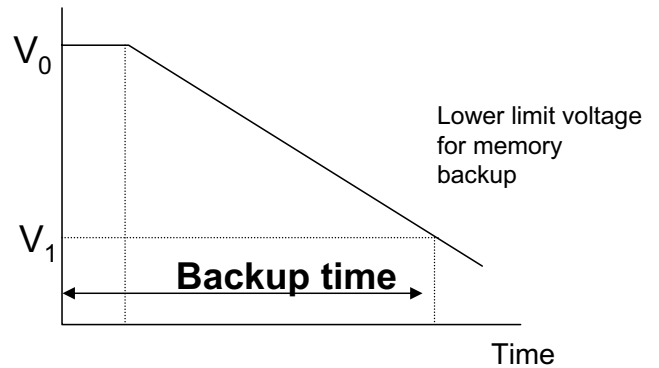

Example:

$$V_0 = 2.5V, \quad V_1 = 1.8V, \quad I = 10\mu A, \quad C = 0.2F$$

$$T = 0.2 (2.5 - 1.8) / (10 e^{-6} + 0.2 \times 10^{-6})$$

$$= 0.14 / 10.2 \times 10^{-6}$$

$$= 13,725 \text{ seconds}$$

$$= 3.8 \text{ hours}$$

- T: Backup time (second)
- C: Capacitance of Gold Capacitor (F)
- V_0 : Applied voltage(V)
- V_1 : Lower limit voltage for memory backup(V)
- I: Current during backup(A)
- I_L : Leakage current(A) about 0.2 μ A

Comparison with Batteries		
	Electric Double Layer Capacitors	Secondary Batteries
Environment	Friendly	Harmful
Cycle Life (Charge & Discharge)	Infinite	Thousands of times
Operating Temperature	-25 to +85°C	-10 to +60°C
Capacity	1	20

1. RoHS compliant.
2. No recycling is required.
3. Stable charge and discharge cycle - Capacitor lifetime is not affected by the amount of charging/dischargin cycles because there is no chemical reaction.
4. Quick charge & Discharge - Seconds or minutes of charge time is enough for use.
(Longer time is necessary for full charge.)
5. Wide Operating Temperature Range - Available for -25 to +85°C
(NOTE: Temperature range depends on the series, please check data sheet for details.)

Stacked Coin Type

Series: SD

Country of Origin

■ Feature

Endurance : 70°C 1000 h

Japan



■ Recommended Applications

Memory back-up for video and audio equipment, cameras, telephones, printers, data terminals, rice cookers, intelligent remote controls

■ Specifications

Category temp. range	-25 to +70°C	
Maximum Operating Voltage	5.5 V .DC	
Nominal Cap. Range	0.022 to 0.33 F	
Characteristics at Low Temperature	Capacitance change	±30% of initial measured value at +20°C (-25 to +70°C)
	Internal resistance	≤ 5 times of initial measured value at +20°C (at -25°C)
Endurance	After 1000 hours application of 5.5V. DC at +70°C, the capacitor shall meet the following limits.	
	Capacitance change	±30% of initial measured value
	Internal resistance	≤ 4 times of initial specified value
Shelf Life	After 1000 hours storage at +70°C without load, the capacitor shall meet the specified limits for Endurance.	
Moisture Resistance	After 500 hours storage at +55°C, 90 to 95% R.H., the capacitor shall meet the specified limits for Endurance.	

■ Dimensions in mm (not to scale)

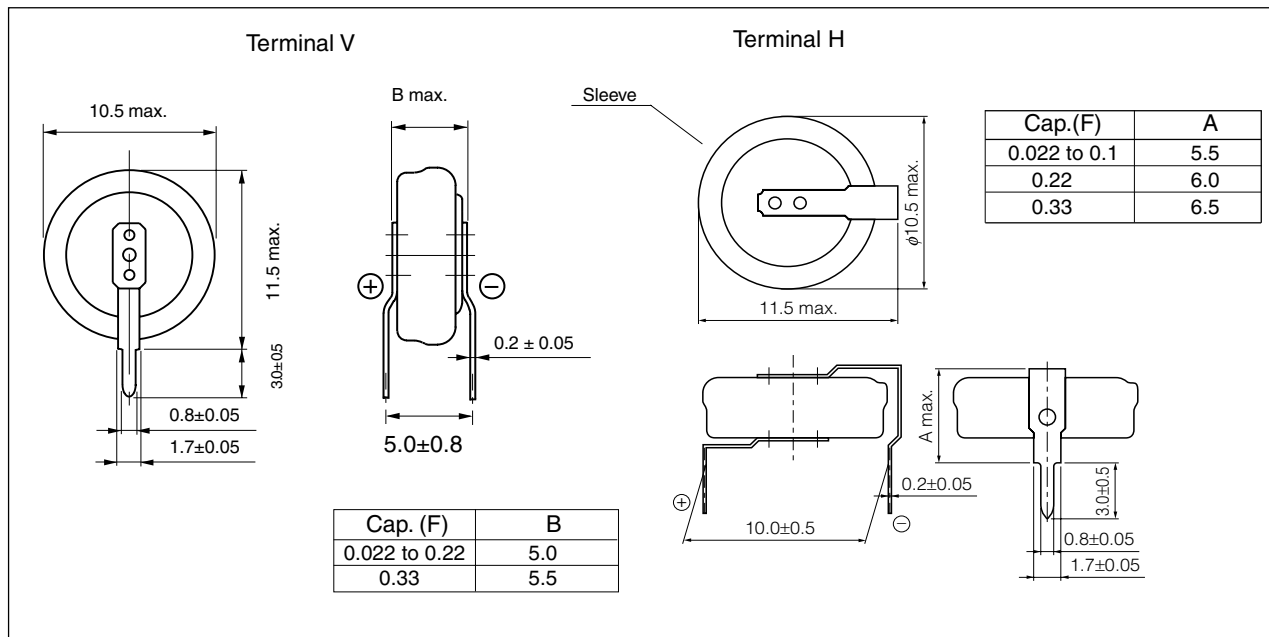

■ Standard Products

Maximum Operating Voltage (V.DC)	Capacitance (F)	Capacitance range (F)	Internal resistance (Ω) at 1kHz	Part number	Min. Packaging QTY (PCS)
5.5	0.022	0.0176 to 0.0396	≤150	EECS0HD 223()	200
	0.047	0.0376 to 0.0846	≤120	EECS0HD 473()	200
	0.10	0.080 to 0.180	≤ 75	EECS0HD 104()	200
	0.22	0.176 to 0.396	≤ 75	EECS0HD 224()	200
	0.33	0.264 to 0.594	≤ 75	EECS0HD 334()	200

() Please use V or H, to indicate the terminal style.

Note: Do not use reflow soldering.(IR,Atmosphere heating methods etc.)

Stacked coin Type

Series: **SG**

Country of Origin

■ **Feature** Endurance : 70°C 1000 h
Maximum height of 6 mm (H Terminal)

Japan



■ **Recommended Applications**
Memory back-up for video and audio equipment, cameras, telephones, printer, data terminals, rice cookers and intelligent remote controls.

■ **Specifications**

Category temp. range	-25 to +70°C	
Maximum Operating Voltage	5.5 V .DC	
Nominal Cap. Range	0.47 to 1.5 F	
Characteristics at Low Temperature	Capacitance change	±30% of initial measured value at +20°C (-25 to +70°C)
	Internal resistance	≤ 5 times of initial measured value at +20°C (at -25°C)
Endurance	After 1000 hours application of 5.5V. DC at +70°C, the capacitor shall meet the following limits.	
	Capacitance change	±30% of initial measured value
	Internal resistance	≤ 4 times of initial specified value
Shelf Life	After 1000 hours storage at +70°C without load, the capacitor shall meet the specified limits for Endurance.	
Moisture Resistance	After 500 hours storage at +55°C, 90 to 95% R.H., the capacitor shall meet the specified limits for Endurance.	

■ **Dimensions in mm (not to scale)**

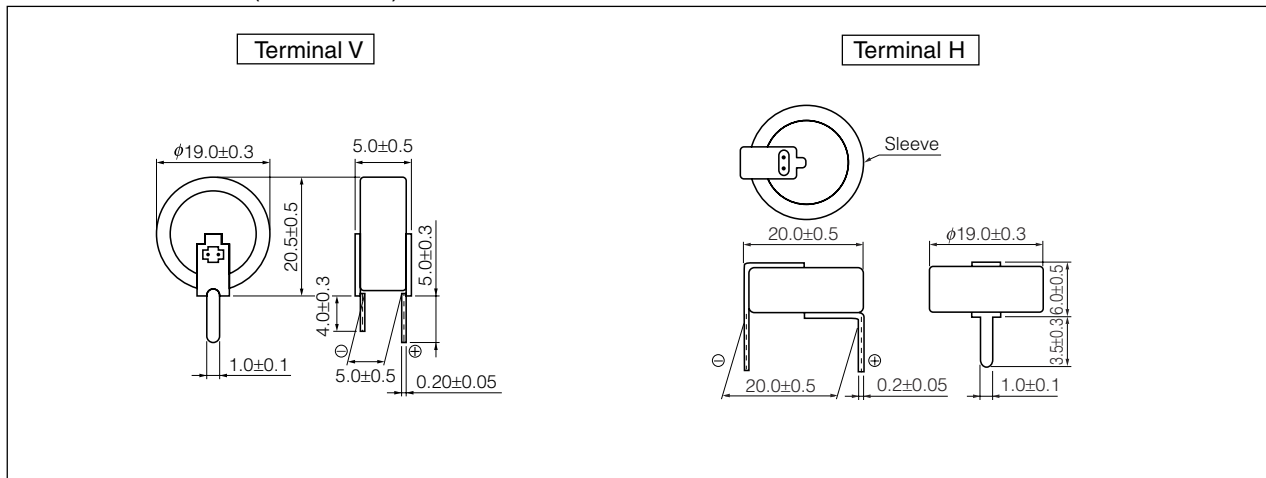

■ **Standard Products**

Maximum Operating Voltage	Capacitance (F)	Capacitance range (F)	Internal resistance (Ω) at 1kHz	Part number	Min. Packaging QTY (PCS)
5.5	0.47	0.376 to 1.41	≤ 30	EECS5R5()474	100
	1.0	0.80 to 1.80	≤ 30	EECS5R5()105	100
	1.5	1.20 to 2.70	≤ 30	EECS5R5()155	100

() Please use V or H, to indicate the terminal style.

Note: Do not use reflow soldering. (IR, Atmosphere heating methods etc.)

Stacked coin Type

Series: SE

Country of Origin

■ Feature

Endurance : 70°C 1000 h
Automatic insertion available

Japan

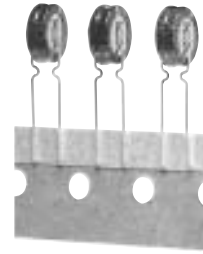

■ Recommended Applications

Memory back-up for video and audio equipment, cameras, telephones, printers, data terminals, rice cookers and intelligent remote controls.

■ Specifications

Category temp. range	-25 to +70°C	
Maximum Operating Voltage	5.5 V .DC	
Nominal Cap. Range	0.022 to 0.22 F	
Characteristics at Low Temperature	Capacitance change	±30% of initial measured value at +20°C (-25 to +70°C)
	Internal resistance	≤ 5 times of initial measured value at +20°C (at -25°C)
Endurance	After 1000 hours application of 5.5V. DC at +70°C, the capacitor shall meet the following limits.	
	Capacitance change	±30% of initial measured value
	Internal resistance	≤ 4 times of initial specified value
Shelf Life	After 1000 hours storage at +70°C without load, the capacitor shall meet the specified limits for Endurance.	
Moisture Resistance	After 500 hours storage at +55°C, 90 to 95% R.H., the capacitor shall meet the specified limits for Endurance.	

■ Dimensions in mm (not to scale)

Dimensions	Nominal	Tolerance
φd	0.55	± 0.05
P ₀	12.7	± 0.2
F	5.0	+0.8 -0.2
W	18.0	±0.5
W ₀	5.5≤	-
W ₁	9.0	±0.5
W ₂	0 to 3.0	-
H	18.0	±0.5
φD ₀	4.0	±0.2
P	12.7	±1.0
P ₁	3.85	±0.50
P ₂	6.35	±1.00
Δh, Δh ₁	0	±1.0
H ₁	28.5≤	-

*Expected dimensions of the capacitor above the board after soldering

■ Standard Products

Maximum Operating Voltage (V.DC)	Capacitance (F)	Capacitance range (F)	Internal resistance (Ω) at 1kHz	Part number	Min. Packaging QTY (PCS)
5.5	0.022	0.0176 to 0.0396	≤ 150	EECSE0H223	1000
	0.047	0.0376 to 0.0846	≤ 120	EECSE0H473	1000
	0.10	0.080 to 0.180	≤ 75	EECSE0H104	1000
	0.22	0.176 to 0.396	≤ 75	EECSE0H224	1000

- Note: 1. When ordering please observe the minimum packaging quantity.
 2. When the surface mount component goes through UV or a heat oven to affix the adhesive glue, the capacitor's surface temperature should not exceed 100°C for more than 60 seconds(maximum temperature should not exceed 105°C)
 3. Do not use reflow soldering. (IR, Atmosphere heating methods etc.)

Stacked coin Type

Series: **NF**

Country of Origin

■ Feature

Endurance : 70°C 1000 h

Japan



■ Recommended Applications

Memory back-up for video and audio equipment, cameras, telephones, printers, data terminals, rice cookers and intelligent remote controls.

■ Specifications

Category temp. range	-25 to +70°C	
Maximum Operating Voltage	5.5 V .DC	
Nominal Cap. Range	0.1 to 1.5 F	
Characteristics at Low Temperature	Capacitance change	±30% of initial measured value at +20°C (-25 to +70°C)
	Internal resistance	≤ 5 times of initial measured value at +20°C (at -25°C)
Endurance	After 1000 hours application of 5.5V. DC at +70°C, the capacitor shall meet the following limits.	
	Capacitance change	±30% of initial measured value
	Internal resistance	≤ 4 time of initial specified value
Shelf Life	After 1000 hours storage at +70°C without load, the capacitor shall meet the specified limits for Endurance.	
Moisture Resistance	After 500 hours storage at +55°C, 90 to 95% R.H., the capacitor shall meet the specified limits for Endurance.	

■ Dimensions in mm (not to scale)

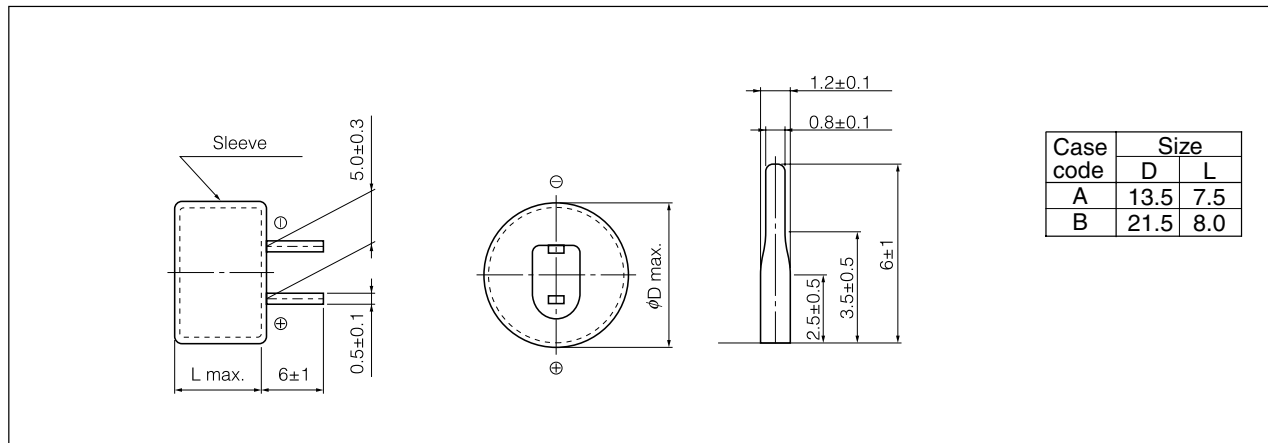

■ Standard Products

Maximum Operating Voltage (V.DC)	Capacitance (F)	Capacitance range (F)	Internal resistance (Ω) at 1kHz	Case code	Part number	Min. Packaging QTY.	
						Quantity per box (pcs)	Quantity per outer packaging (pcs)
5.5	0.10	0.08 to 0.18	≤ 75	A	EECF5R5U104	200	2000
	0.22	0.176 to 0.396	≤ 75	A	EECF5R5U224	200	2000
	0.47	0.376 to 1.410	≤ 30	B	EECF5R5U474	100	500
	1.0	0.80 to 1.80	≤ 30	B	EECF5R5U105	100	500
	1.5	1.20 to 2.70	≤ 30	B	EECF5R5U155	100	500

Note: Do not use reflow soldering. (IR, Atmosphere heating methods etc.)

Stacked Coin Type

Series: F

Country of Origin

Japan



■ Feature Endurance : +85°C 1000 h

■ Specifications

Category temp. range	-25 to +85°C	
Maximum Operating Voltage	5.5 V .DC	
Nominal Cap. Range	0.047 to 1.0 F	
Characteristics at Low Temperature	Capacitance change	±30% of initial measured value at +20°C (-25 to +85°C)
	Internal resistance	≤ 5 times of initial measured value at +20°C (at -25°C)
Endurance	After 1000 hours application of 5.5V. DC at +85°C, the capacitor shall meet the following limits.	
	Capacitance change	±30% of initial measured value
	Internal resistance	≤ 4 times of initial specified value
Shelf Life	After 1000 hours storage at +85°C without load, the capacitor shall meet the specified limits for Endurance.	
Moisture Resistance	After 500 hours storage at +55°C, 90 to 95% R.H., the capacitor shall meet the specified limits for Endurance.	

■ Dimensions in mm (not to scale)

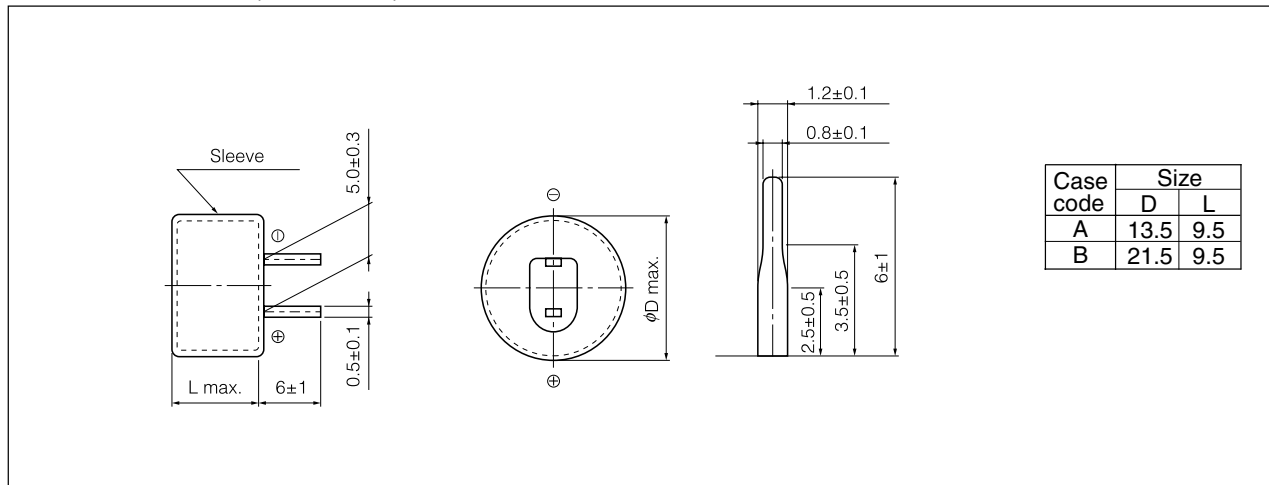

■ Standard Products

Maximum Operating Voltage (V.DC)	Capacitance (F)	Capacitance range (F)	Internal resistance (Ω) at 1kHz	Case code	Part number	Min. Packaging QTY.	
						Quantity per box (pcs)	Quantity per outer packaging (pcs)
5.5	0.047	0.0376 to 0.0846	≤ 120	A	EECF5R5H473	200	2000
	0.10	0.080 to 0.180	≤ 100	A	EECF5R5H104	200	2000
	0.47	0.376 to 0.846	≤ 75	B	EECF5R5H474	100	500
	0.68	0.476 to 1.224	≤ 50	B	EECF5R5H684	100	500
	1.00	0.80 to 1.80	≤ 50	B	EECF5R5H105	100	500

Note: Do not use reflow soldering. (IR, Atmosphere heating methods etc.)

Radial lead Type

Series: HW

Country of Origin

Japan

■ Feature

- Miniaturized, high-capacitance and low resistance
- Can be charged and discharged with more cycles compared to secondary batteries
- Pollution free: Has activated carbon and organic electrolytes
- Does not contain polyvinyl chloride and lead

■ Recommended Applications

- Solar battery operated circuits (Road guidance flasher)
- Quick charging motor drives (Toy car)
- Back-up Power Supplies (UPS)



■ Specifications

Category temp. range	-25 to +70°C		-25 to +60°C	
Maximum Operating Voltage	2.3 V .DC		2.3 V .DC	
Nominal Cap. Range	1 to 22 F		30, 50 F	
Capacitance Tolerance	-20 to +40%			
Characteristics at Low Temperature	Capacitance change	±30% of initial measured value at +20°C (-25 to +70°C, +60°C)		
	Internal resistance	≤ 4 times of initial measured value at +20°C (at -25°C)		
Endurance	After 1000 hours application of 2.3V. DC at +70°C(+60°C), the capacitor shall meet the following limits.			
	Capacitance change	±30% of initial measured value		
	Internal resistance	≤ 2 time of initial specified value		
Shelf Life	After 1000 hours storage at +70°C(+60°C) without load, the capacitor shall meet the specified limits for Endurance.			
Moisture Resistance	After 500 hours storage at +55°C, 90 to 95% R.H., the capacitor shall meet the specified limits for Endurance.			

■ Dimensions in mm (not to scale)

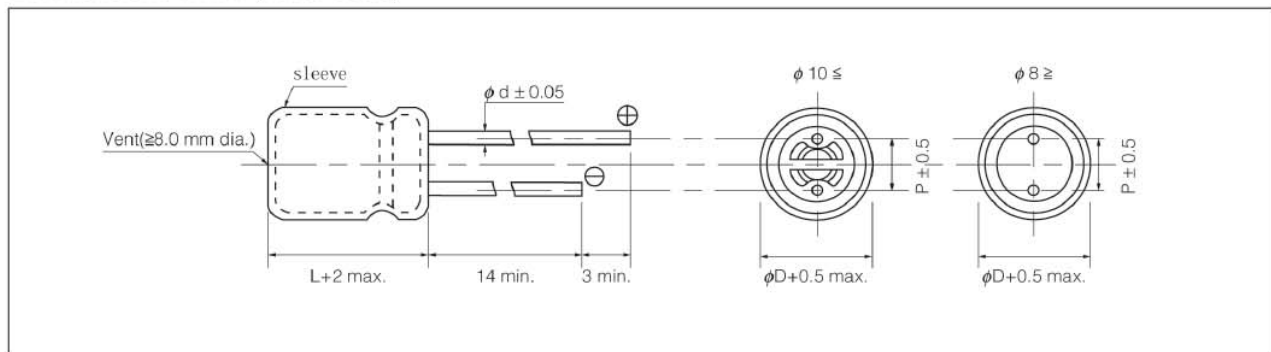

■ Standard products

Category temp. range (°C)	Max. Operating Voltage (V.DC)	Capacitance (F)	Internal resistance (Ω) at 1kHz	Size(mm)				Part number	Min. Packaging QTY (pcs)
				φD	L	φd	P		
-25 to +70	2.3	1.0	≤ 1.0	8.0	22.0	0.7	3.5	EECHW0D105	200
		3.3	≤ 0.3	12.5	23.0	0.8	5.0	EECHW0D335	200
		4.7	≤ 0.3	12.5	23.0	0.8	5.0	EECHW0D475	200
		10	≤ 0.2	12.5	35.0	0.8	5.0	EECHW0D106	100
		22	≤ 0.1	18.0	35.0	0.8	7.5	EECHW0D226	50
-25 to +60		30	≤ 0.1	18.0	35.0	0.8	7.5	EECHW0D306	50
		50	≤ 0.1	18.0	40.0	0.8	7.5	EECHW0D506	50
-25 to +60	2.1	70	≤ 0.1	18.0	50.0	0.8	7.5	EECHW0D706	50

Surface Mount Type

Series: EN

Country of Origin

■ Feature

1. Re-flow soldering method available (240°C)
2. Miniaturized : Diaφ6.8 x height 1.8mm max.
3. Longer life and environmentally friendly

Japan



■ Recommended Applications

Memory cards(power supply to hold memory), mobile phones, PDAs, digital cameras.

■ Specifications

Category temp. range	-10 to +60°C	
Maximum Operating Voltage	3.3 V .DC	
Nominal Capacitance	0.2 F	
Maximum Operating Current	10 μA MAX	
Stability at low temperature and high temperature	Category temp. range(-10°C)	
	Capacitance change	±30% of initial measured value at +20°C
	Internal resistance	≤10 times of initial measured value at +20°C
	Category temp. range(+60°C)	
	Capacitance change	±30% of initial measured value at +20°C
	Internal resistance	≤ measured value at +20°C
Endurance	After 500 hours application of 3.3V. DC at +60°C, the capacitor shall meet the following limits.	
	Capacitance change	±30% of initial measured value
	Internal resistance	≤ 20 times of initial specified value
Shelf Life	After 500 hours storage at +60°C without load, the capacitor shall meet the specified limits for Endurance.	
High temperature High humidity	After 500 hours storage at +40°C, 90 to 95% R.H., the capacitor shall meet the following limits.	
	Capacitance change	±30% of initial measured value
	Internal resistance	≤ 1 k ohm or less

■ Dimensions in mm (not to scale)

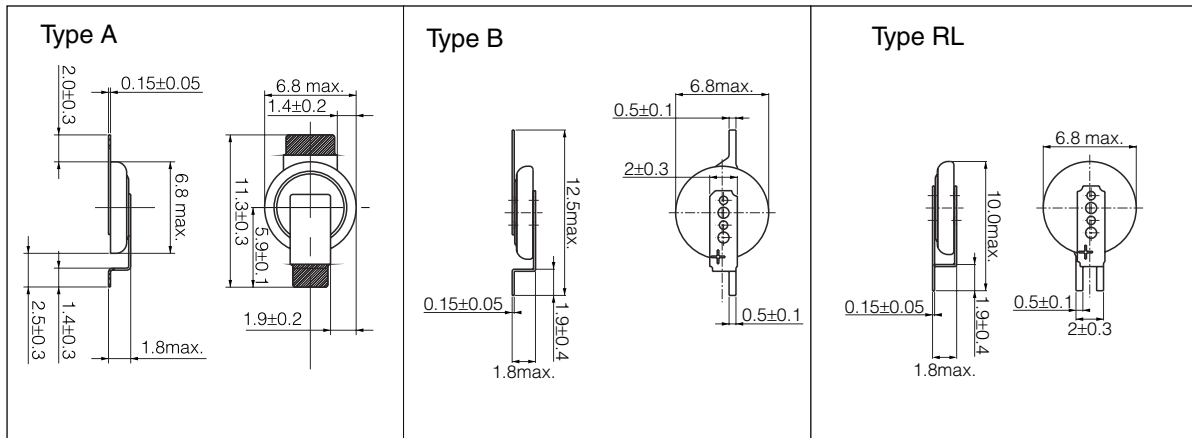

■ Standard Products

Maximum Operating Voltage (V.DC)	Capacitance (F)	Capacitance range (F)	Internal resistance (Ω) at 1kHz	Mass (g)	Part number	Min. Packaging QTY
						Reel (pcs)
3.3	0.2	0.16 to 0.36	200	0.2 (Approx.)	EECEN0F204()	2000

The re-flow condition / taping dimensions are explained on p.205 of our Catalog.

Please use it as a reference guide.

(): Please use A,B or RL to indicate terminal type.

Note: 1. When the capacitor is being used in a high temperature and high humidity environment for a long period, brown deposited materials might be found around the sealing area. However, the materials are insulators and will not affect any electrical characteristics of the capacitor.

2. Do not use reflow soldering when cell voltage is above 0.3V.