

Manual

Locomotive decoders series 30 *plus*

DCC

MM



LD-G-31 *plus*

Item 41-03310

Item 41-03312

Item 41-03313



LD-G-33 *plus*

Item 41-03330

Item 41-03332

Item 41-03333

Item 41-03334

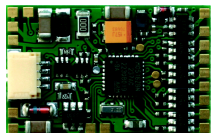

LD-G-34 *plus*

Item 41-03340

Item 41-03341

Item 41-03342



LD-G-36 *plus*

Item 41-03360x

Item 41-03362x

Item 41-03363x

Item 41-03364x

tams elektronik



Contents

1. Getting started.....	6
2. Safety instructions.....	9
3. Safe and correct soldering.....	12
4. Operation overview.....	13
4.1. Modes of operation.....	13
4.2. Driving of the motor.....	15
4.3. Function outputs.....	17
4.4. Sound functions.....	18
4.5. Releasing the functions.....	20
4.6. Automated processes.....	21
4.7. Feedback with RailCom** and RailCom plus **.....	23
4.8. Overload protection (except LD-G-31 plus).....	24
4.9. POM-update (except LD-G-36 plus).....	25
5. Technical specifications.....	26
6. Connections.....	29
6.1. Connector pin assignment LD-G-31 plus (PluX12).....	30
6.2. Connector pin assignment LD-G-33 plus (PluX22).....	32
6.3. Connector pin assignment LD-G-33 plus (21MTC, 21-pole).....	34
6.4. Connector pin assignment LD-G-34 plus.....	36
6.5. Connector pin assignment LD-G-36 plus (PluX22).....	38
6.6. Connector pin assignment LD-G-36 plus (21MTC, 21-pole).....	40
6.7. Using decoders with interface connectors.....	43
6.8. Use in locomotives with a.c. motor.....	44
6.9. INFO: Earth connections and voltage outputs.....	45
6.10. Mounting decoders without interface.....	46
6.11. Connecting LEDs to the function outputs.....	48
6.12. Connecting inductive loads.....	50

6.13. Connecting accessories via a relay.....	50
6.14. Connecting a loudspeaker.....	51
6.15. Connecting a buffer capacitor.....	51
6.16. Connecting a servo (not with LD-G-31).....	52
6.17. Connecting the switching inputs.....	53
6.18. Connecting a SUSI module (except LD-G-31 plus).....	55
6.19. Connecting a clock generator to the LD-G-36 plus.....	55
6.20. Fixing the decoder.....	55
7. Programming.....	56
8. Configuration variables and registers.....	59
9. Performing a POM-Update.....	82
10. Check list for troubleshooting.....	84
11. Guarantee bond.....	88
12. EU declaration of conformity.....	89
13. Declarations conforming to the WEEE directive.....	89

© 11/2015 Tams Elektronik GmbH

All rights reserved. No part of this publication may be reproduced or transmitted in any form or by any means, electronic or mechanical, including photocopying, without prior permission in writing from Tams Elektronik GmbH.

Subject to technical modification.

The asterisks **

RailCom® is the registered trademark of:

Lenz Elektronik GmbH | Vogelsang 14 | DE-35398 Gießen

RailComPlus® is the registered trademark of:

Lenz Elektronik GmbH | Vogelsang 14 | DE-35398 Gießen and

ESU electronic solutions ulm GmbH & Co. KG | Edisonallee 29 |

DE-89231 Neu-Ulm

To increase the text's readability we have refrained from referring to this point in each instance.

This manual mentions the following companies:

Gebr. MÄRKLIN & Cie. GmbH | Stuttgarter Str. 55-57 | DE-73033 Göppingen

Uhlenbrock Elektronik GmbH | Mercatorstraße 6 | DE-46244 Bottrop

1. Getting started

This manual applies to all locomotive decoders of the series 30 plus, so for:

- locomotive decoder LD-G-31 plus,
- locomotive decoder LD-G-33 plus,
- locomotive decoder LD-G-34 plus,
- sound locomotive decoder LD-G-36 plus.

Provided there are no other details given for particular sections, the information given applies to all decoders.

How to use this manual

This manual gives step-by-step instructions for safe and correct fitting and connecting of the decoder, and operation. Before you start, we advise you to read the whole manual, particularly the chapter on safety instructions and the checklist for trouble shooting. You will then know where to take care and how to prevent mistakes which take a lot of effort to correct.

Keep this manual safely so that you can solve problems in the future. If you pass the decoder on to another person, please pass on the manual with it.

Intended use

The locomotive decoders of the series 30 plus are designed to be operated according to the instructions in this manual in model building, especially in digital model railroad layouts. Any other use is inappropriate and invalidates any guarantees.

The locomotive decoders should not be mounted by children under the age of 14.

Reading, understanding and following the instructions in this manual are mandatory for the user.

Checking the package contents

Please make sure that your package contains:

- one or five locomotive decoders, depending on the version with or without soldered connecting wires resp. with or without interface connector;
- LD-G-31 plus: one or five buffer electrolytic capacitors (100 μ F / 35 V);
- LD-G-33 plus, LD-G-34 plus, LD-G-36 plus: one or five buffer electrolytic capacitors (220 μ F / 35 V);
- LD-G-31 plus, LD-G-33 plus, LD-G-34 plus: one or five suppression chokes (470 μ H / \geq 90mA);
- a CD (containing the manual, Software "POM-Updater.exe" and further information).

N.B. For technical reasons it is possible that the PCB is not completely inserted. This is not a fault.

Available versions

Connecting wires / Interface	LD-G-31 plus	LD-G-33 plus	LD-G-34 plus	LD-G-36 plus
without wires *1	+	+	+	+
with wires *1	-	-	+	-
according to NEM 650*1	8-pole (NEM 652)	8-pole (NEM 652)	8-pole (NEM 652)	8-pole (NEM 652)
according to NEM 658	PluX12	PluX22	-	PluX22
according to NEM 660	-	21MTC	-	21MTC
similar to NEM 660	-	21-pole*2 (4 amplified outputs)	-	21-pole (4 amplified outputs)

*1 connections according to version with PluX interface

*2 in preparation (status 11/2015)

Required materials

For mounting and connecting decoders without interface you need:

- an electronic soldering iron (max. 30 Watt) or a regulated soldering iron with a fine tip and a soldering iron stand,
- a tip-cleaning sponge,
- a heat-resistant mat,
- a small side cutter, a wire stripper and a pair of tweezers,
- electronic tin solder (0.5 mm diameter).

In order to connect decoders without interface or soldered connecting wires you will need wire. Recommended cross sections:

- $\geq 0,04 \text{ mm}^2$ for the connections to the function outputs;
- $\geq 0,05 \text{ mm}^2$ for the connections to the motor and current collectors (except for the LD-G-34 plus);
- $\geq 0,14 \text{ mm}^2$ for connections to the motor and current collectors of the LD-G-34 plus.

For playing back the sounds you need:

- a loudspeaker with an impedance of min. 4 Ohm and a rated load-carrying capacity of min. 0,1 Watt.

If you want to trigger switching operations automatically, e.g.:

- reed contacts 1 x closing contact (e.g. item-no. 84-53110) and / or
- Hall-sensors (e.g. item-no. 84-53210) and
- permanent magnets (e.g. neodymium magnets \varnothing 3mm, thickness = 2mm, item-no. 84-53990);
- for the connection via the SUSI connector plug of the decoder: a SUSI socket with wires (e.g. item no. 70-01111).

If you want to use the output for the servo:

- one servo,
- a voltage supply for the servo (e.g. servo PCB item-no. 70-05900).

As a clock generator for the sound locomotive decoder LD-G-36 plus (e.g. to control the correct synchronisation of the steam discharge with the wheel movements):

- reed contacts 1 x closing contact (e.g. item-no. 84-53110)
- and / or Hall-sensors (e.g. item-no. 84-53210) and
- permanent magnets (e.g. neodymium magnets Ø 3mm, thickness = 2mm, item-no. 84-53990).

If you want to connect the decoder to an a.c. motor:

- a load control adapter LRA (item no. 70-02105 or 70-02106) or
- a permanent magnet (e.g. item no. 70-04100, 70-04200 or 70-04300) or
- a motor modification set (e.g. item no. 70-40110, 70-40210 or 70-40310).

2. Safety instructions



Caution:

Integrated circuits (ICs) are inserted on the decoder. They are sensitive to static electricity. Do not touch components without first discharging yourself. Touching a radiator or other grounded metal part will discharge you.

Mechanical hazards

Cut wires can have sharp ends and can cause serious injuries. Watch out for sharp edges when you pick up the PCB.

Visibly damaged parts can cause unpredictable danger. Do not use damaged parts: recycle and replace them with new ones.

Electrical hazards

- Touching powered, live components,
- touching conducting components which are live due to malfunction,
- short circuits and connecting the circuit to another voltage than specified,

impermissibly high humidity and condensation build up

can cause serious injury due to electrical shock. Take the following precautions to prevent this danger:

- Never perform wiring on a powered module.
- Assembling and mounting the kit should only be done in closed, clean, dry rooms. Beware of humidity.
- Only use low power for this module as described in this manual and only use certified transformers.
- Connect transformers and soldering irons only in approved mains sockets installed by an authorised electrician.
- Observe cable diameter requirements.
- After condensation build up, allow a minimum of 2 hours for dispersion.
- Use only original spare parts if you have to repair the kit or the ready-built module.

Fire risk

Touching flammable material with a hot soldering iron can cause fire, which can result in injury or death through burns or suffocation. Connect your soldering iron or soldering station only when actually needed. Always keep the soldering iron away from inflammable materials. Use a suitable soldering iron stand. Never leave a hot soldering iron or station unattended.

Thermal danger

A hot soldering iron or liquid solder accidentally touching your skin can cause skin burns. As a precaution:

- use a heat-resistant mat during soldering,
- always put the hot soldering iron in the soldering iron stand,
- point the soldering iron tip carefully when soldering, and
- remove liquid solder with a thick wet rag or wet sponge from the soldering tip.

Dangerous environments

A working area that is too small or cramped is unsuitable and can cause accidents, fires and injury. Prevent this by working in a clean, dry room with enough freedom of movement.

Other dangers

Children can cause any of the accidents mentioned above because they are inattentive and not responsible enough. Children under the age of 14 should not be allowed to work with this kit or the ready-built module.

**Caution:**

Little children can swallow small components with sharp edges, with fatal results! Do not allow components to reach small children.

In schools, training centres, clubs and workshops, assembly must be supervised by qualified personnel.

In industrial institutions, health and safety regulations applying to electronic work must be adhered to.

3. Safe and correct soldering

**Caution:**

Incorrect soldering can cause dangers through fires and heat. Avoid these dangers by reading and following the directions given in the chapter **Safety instructions**.

- Use a small soldering iron with max. 30 Watt. Keep the soldering tip clean so the heat of the soldering iron is applied to the solder point effectively.
- Only use electronic tin solder with flux.
- When soldering electronic circuits never use soldering-water or soldering grease. They contain acids that can corrode components and copper tracks.
- Solder quickly: holding the iron on the joints longer than necessary can destroy components and can damage copper tracks or soldering eyes.
- Apply the soldering tip to the soldering spot in such a way that the wire and the soldering eye are heated at the same time. Simultaneously add solder (not too much). As soon as the solder becomes liquid take it away. Hold the soldering tip at the spot for a few seconds so that the solder flows into the joint, then remove the soldering iron.
- The joint should be held still for about 5 seconds after soldering.
- To make a good soldering joint you should use a clean and unoxidised soldering tip. Clean the soldering tip with a damp piece of cloth, a damp sponge or a piece of silicon cloth.
- After soldering check (preferably with a magnifying glass) tracks for accidental solder bridges and short circuits. This would cause faulty operation or, in the worst case, permanent damage. You can remove excess solder by putting a clean soldering tip on the spot. The solder will become liquid again and flow from the soldering spot to the soldering tip.

4. Operation overview

4.1. Modes of operation

Digital operation

The locomotive decoder is a multiple protocol decoder, that can operate with and automatically recognise both DCC or Motorola formats.

The number of addresses is dependant on the format being used:

- Motorola-Format: 255 addresses,
- DCC-Format: 127 Basis-addresses or 10.239 extended addresses.

In the DCC format the decoder can be driven in all speed levels (14, 28 or 128). In the Motorola format the decoder can be driven in 14 or 27 speed levels. Driving all 27 speed levels can be done only with central units which support this mode (e.g. MasterControl). With central units which allow 14 speed levels only, it is only possible to select every second speed level.

Programming the decoders is done:

- in Motorola format by setting the registers,
- in DCC format by setting the configuration variables (direct programming, DCC conform) or by POM (programming on main = main track programming). Note: The configuration variables reserved for the SUSI interface ## 897 – 1024 cannot be programmed by POM.

Analogue mode

The locomotive decoder can also be used in analogue model railway layouts run with a D.C. or A.C. speed control. When putting the vehicle on the rails the decoder recognizes automatically if it is run in analogue or digital mode and sets the corresponding operation mode. The automatic recognition of the analogue mode can be switched off.



Caution:

Old analogue driving transformers (e.g. models in a blue housing from Märklin**) are not suitable for use with digital decoders in analogue operation! These transformers have been designed for the older supply voltage of 220 V and, due to construction, generate very high excess voltage impulses when changing the driving direction. When using them with the modern supply voltage of 230 V too high excess voltage impulses can occur, damaging electronic parts on the decoder. For that reason only use driving transformers designed for a net voltage of 230 V.

Switching the function outputs on or off is not possible in analogue mode. They can be programmed so that they are either switched on or off in analogue mode. The effects set for the outputs are active in analogue mode as well.

Outputs to be switched with F0 are switched on or off in analogue mode according to the direction of travel. When operated in analogue d.c. layouts this applies only to lamps or accessories where the return conductor is connected to the decoder's common return conductor for all function outputs.

The decoders' load control is also active in analogue mode. The set maximum speed also limits in analogue mode the maximum speed of the locomotive.

4.2. Driving of the motor

Pulse width modulation

The pulse width modulation (PWM) of the locomotive decoder can be set to a value between 60 Hz and 30 kHz. This enables you to adjust the decoder individually to the different motor types, including coreless motors.

Load control

The decoder has a load control. The load control influences the motor voltage to keep the locomotive with a set speed level at constant velocity, independent of additional loads (e.g. running up a gradient, coupled carriages).

It is possible to switch on and off the load control by varying a CV-variable of the decoder. The parameters of the load control may be altered, in order to adapt the decoder to the motor's individual characteristics.

Parameters of the load control: The load control is determined by three parameters which have to be coordinated in order to achieve optimal driving characteristics. Each of the load control parameters is assigned to a configuration variable. The parameters are:

KP: The proportional component of the load control ensures the difference between the set and the present value being as small as possible. It cannot have the value "0" at any time. This component affects the basic speed. In case the set value is too small the locomotive runs too slowly. In case the set value is too high the locomotive stutters while moving.

KI: The integral component of the load control ensures the remaining difference between the set and the present value is reduced to 0 and so for the correction of very small divergences. If the set value is too high the locomotive stutters massively while moving.

KD: The differential component of the load control ensures that the control is not converted too quickly. Is the set value too low then the locomotive stutters. If the set value is too high, the locomotive rocks while moving.

Velocity characteristic

The decoder can be adjusted to the driving characteristics of the motor and the characteristic speed of the locomotive type, by setting the starting, medium and maximum velocity. From these three settings the decoder generates a (where required turned) linear velocity characteristic.

When the speed level mode is set to 28 speed levels, it is possible to assign any motor voltage to all of the 28 speed levels as an alternative to the linear velocity characteristic. This allows the programming of a velocity characteristic which adjusts the individual driving characteristics of the motor. The set values are saved in the alternative velocity table.

Shunting gear

It is possible to switch into the shunting gear mode via a function key (in state of delivery F3), when so programmed. In the shunting gear mode, the velocity of all speed levels is reduced to approx. 50 % compared to the set velocity.

Acceleration and brake delay

It is possible to program the acceleration and brake delay individually via the central unit. When so programmed, it can be switched on and off with a function key (in state of delivery F4).

4.3. Function outputs

The decoder has function outputs, which are available to connect optional accessories (e.g. lighting, smoke generator, sound module, electric coupling). The accessories' number and type to be connected depends on the outputs' number and maximum current as well as on the maximum total current of the special decoder (see section 5 "Technical specifications").

Effects of the function outputs

It is possible to set the following effects for the function outputs (except AUX7) individually:

- Switching on and off depending on the direction of travel.
- Flashing and double flashing. Both the frequency and the keying ratio can be set. E.g. single and double flash lights or strobe lights.
- Kick function: It is possible to set the amplified function outputs so that they get the full voltage first for up to 12,5 seconds and then are switched off. Example of use: For some types of electric couplings you need the full voltage for decoupling and the voltage then switched off to protect the couplings.
- Shunting light: You can program the outputs so that they are switched on generally during shunting operation (to be switched with F3 or F4). The dependence on the direction of travel will be nullified for these outputs during shunting operation.
- Special function for speed level 0: It is possible to program one function to switch off other functions or switch on special function outputs at speed level 0. Example of use: In some locomotive sheds it is customary that the tail lamps of parked locomotives have to be temporarily set at the front and the back.
- Dimming: Example of use: The electric bulbs of older vehicles made for analogue operation can be dimmed and thus must not be exchanged after the mounting of the decoder.

- Dimming depending on the speed level: The voltage will be dimmed depending on the speed level. This enables weak smoke generation during halts or a switched off or dimmed cab lighting while the train is moving.
- MARsight (= light intensity going up and down): Example of use: american locomotives with this type of lighting.

Servo output (except LD-G-31 plus)

The decoders LD-G-33 plus, LD-G-34 plus and LD-G-36 plus have an output sending the signals to control a servo. The voltage supply for the servo cannot be provided by the decoder. For that reason an external voltage supply (e.g. servo PCB item-no. 70-05900) is required.

The servo is controlled by:

- setting the end positions via CVs and controlling by pushing the function keys ("on" = end position 1 , "off" = end position 2) or
- input of a value for the folding square by POM, which allows to approach to any folding square.

4.4. Sound functions

SUSI interface (except LD-G-31 plus)

A SUSI module can be connected to the locomotive decoders LD-G-33 plus, LD-G-34 plus and LD-G-36 plus and read out, programmed and controlled via the decoder.

The decoder transmits the function status and the speed level set at the central unit, to the SUSI module. This affects the SUSI module's outputs depending on the speed level (e.g. motor sound). The decoder allows the setting of the acceleration and braking delay so that the functions depending on the speed level correspond to the driving characteristics during accelerating and braking.

Integrated sounds (except LD-G-36 plus)

The locomotive decoders LD-G-31 plus, LD-G-33 plus and LD-G-34 plus have three integrated sounds:

- locomotive whistle,
- bell,
- signal horn.

Driving sound (LD-G-36 plus only)

You can trigger different sounds via the digital control unit's function keys (standing and driving sound, signal horn or locomotive whistle, decoupling or door closing sound, bell or second signal horn). The function keys can be assigned freely to the sounds.

Four sounds typical for a locomotive type are saved on an IC in the decoder. They are recordings of original sounds of the vehicle examples. Before delivery the module is programmed with sounds from a sound data base. Using a special programming device (Tams sound programmer, item no. 70-03200) allows to alter the decoder's programming.

A clock generator (e.g. Hall sensor or reed contact in combination with a magnet) allows to control for example the correct synchronising of the steam discharge with wheel movement.

Possible settings

The settings in state of delivery can be adjusted by changing the configuration variables:

- volume;
- steam discharge of steam locomotives;
- length of the breaks between signal sounds;
- release thresholds at change of motor load, for breaking sound and for ventilator sound of electric locomotives;
- fading time (= period of time of fading in and down when switching on and off);

- sensitivity to load changes;
- time of no-load running;
- assignment of the sounds to the function keys.

4.5. Releasing the functions

The function outputs, the servo output, the integrated sounds and with the LD-G-36 plus the driving sounds can be released by:

- pushing the function keys and / or
- automatically via the two switching inputs. The switching inputs are released via external contacts, e.g. via reed contacts or Hall sensors in combination with permanent magnets in the rails.

Hint for locomotive decoder LD-G-33 plus: When there is connected a SUSI module, the switching inputs are not available.

Hint for locomotive decoders LD-G-34 plus and LD-G-36 plus: The sounds of a connected SUSI module can be triggered by the function keys as well as by the switching inputs that are assigned to these function keys. .

Mapping of the outputs to the function keys

The mapping of the outputs to the function keys and the switching inputs is arbitrary. It is possible to assign several function keys and switching inputs to one output.

Output	DCC format	MM format
F0f / F0r	F0 to F12	F0 to F4 or
AUX1 to AUX6 (LD-G-31 plus: AUX1 to AUX2)	F0 to F28	F5 to F9 (= F0 to F4 of a second decoder address)
AUX7 (versions with connections according to PluX only, except LD-G-31 plus)	F13 to F28	

All function outputs can be switched inverted, i.e. when set to position "on" the assigned function output will be switched off, when set to position "off" switched on.

4.6. Automated processes

The control software in the locomotive decoder allows you to automate procedures and to reduce complex processes to one keystroke.

Automatic commuting operation

It is possible to install an automatic commuting operation between two terminal stations, via the switching inputs. You can assign a function key to the automatic commuting operation, in order to switch it on or off during operation.

Sequence: As soon as the switching input has been released (e.g. by a magnet in the track in combination with a Hall sensor or a reed contact), the locomotive breaks with the set brake delay. After the set stop time the locomotive starts with the set acceleration delay. Depending on the settings, the direction of motion is altered internally and the locomotive runs back into the opposite direction or goes on in the same direction.

When so programmed, closing one of the switching inputs on the main track between the terminal stations will be ignored by the commuting automatic and can be used to trigger any function during commuting operation. Please note, that always all active functions assigned to the switching input are released as soon as the switching input is closed. The second switching input can be used to release additional stops on the commuting line.

Possible settings for CV programming:

- length of the stop time (0 to max. 160 seconds), either commonly for both directions or separately for advancing and reversing;
- whether a change of direction has to be performed after a stop;
- switching off the commuting automatic with function key F5 to F12;
- number of switching impulses between two terminal stations to be ignored (and not releasing the braking for terminal station).

Dimming depending on the velocity

You can automatically switch functions depending on the velocity when reaching a speed level defined in a CV. You assign an individual voltage to the function outputs for the ranges of speed levels underneath and above the defined speed level. This allows for example to switch on and off the high beam light, to control the cab light or to influence the intensity of the steam output.

Shunting function

You can assign the shunting gear and the shunting light to the same function key. That way you switch on the shunting light automatically when switching into the shunting gear (and thus reducing the velocity).

Special function for speed level 0

By programming the special function for speed level 0 you can switch on or off several function outputs and functions at the same time, you otherwise had to switch singularly. This allows e.g. to switch off several lights at once when parking a locomotive in the depot (e.g. front and back lights, cab light and undercarriage light).

Automatic coupling and decoupling

With an appropriate CV-programming you can release coupling and decoupling operations automatically with one function key. In order to use the automatic coupling function you have to assign one function key to each of the directions "forward" and "backward". In order to couple the locomotive drives with the velocity set in a CV against the carriage to be coupled. As soon as the assigned switching input has been connected to earth (e.g. via a current transmitting coupling), the locomotive stops. After having coupled, the primary driving direction is set again.

For decoupling the locomotive first runs a small distance against the set driving direction, in order to relieve the coupling. The function output connected to the coupling is switched on. In order to prevent the

coupling from damage, the current is switched off automatically after the set time. The driving direction is changed over to the set direction of motion and the locomotive drives away a small distance from the decoupled carriage.

4.7. Feedback with RailCom** and RailCom plus **

RailCom is a log for bi-directional communication in digital model railway layouts controlled in DCC-format. It allows e.g. the feedback of the address and the CV values from the decoder to the digital central unit or to special receivers (so-called detectors). The decoders must be designed to send the RailCom messages.

When so programmed, the locomotive decoders of the series 30 plus send (continuously) the (basic, extended or consist) address to the detectors (so-called RailCom broadcast datagramm) and transfer a CV message after a DCC CV read-out command.

Sending RailCom messages is only possible in layouts with a DCC signal on the rails. It is not possible to use the RailCom-function in a pure Motorola environment.

RailComPlus enables the decoder to log in automatically at the digital control unit. In doing so the locomotive address and name as well as the functional mode and range are transmitted. The precondition for using RailComPlus is using a control unit providing this type of feedback.

4.8. Overload protection (except LD-G-31 plus)

The locomotive decoders LD-G-33 plus, LD-G-34 plus and LD-G-36 plus have an overload protection, which prevents them from overheating when exceeding the maximum motor or total current.

As soon as the maximum motor or total current is exceeded, the decoder automatically temporarily switches off. This operation will be repeated until the overload has been eliminated.

When exceeding the maximum current at the output only (but not the total current of the decoder) the decoder's overload protection is without effect, the concerned output will be damaged.

 **Attention:**

When a short circuit occurs that bypasses components on the decoder either to each other or to track voltage, the overload protection is not effective. Examples:

- contact between the decoder and the rails or metal parts of the vehicle;
- contact between not-isolated decoder connecting wires and the rails or metal parts of the vehicle;
- contact between accessories connected to the common return conductor of the decoder and the rails or metal parts of the vehicle.

 **Attention:**

Malfunctions of the locomotive motor (e.g. the so-called "sparking of the brushes") can cause extreme interference current, possibly damaging components on the decoder. The decoder's overload protection is without effect with this extremely high current.

4.9. POM-update (except LD-G-36 plus)

POM-update is a procedure allowing to update the decoder's firmware (= specific decoder software) without dismounting the decoder or using a specific device. POM-update is based upon programming on main (POM) for the DCC format.

Preconditions for using the procedure are:

- Locomotive decoder LD-G-31 plus from version 2.4, locomotive decoder LD-G-33 plus from version 2.5 or locomotive decoder LD-G-34 plus from version 2.5.
- Digital central unit with PC interface providing the DCC format and POM. Hint: As nearly every manufacturer of central units uses his own procedure for programming on main, the POM-update can be performed with the following central units only (status 01/2015):

MasterControl (Tams Elektronik)

Intellibox 1 (Uhlenbrock**)

CS2 (Maerklin**)

The current list of central units allowing to perform the POM-update is available on our homepage.

- PC. The system software must support Java.
- Software "POM-Updater.exe": You will find it on the CD included in delivery. It is also available on our homepage for free download.

You can download the current firmware version of the decoder free of charge from our homepage. If you want to get information on new firmware versions please subscribe to our newsletter on our homepage.

5. Technical specifications

Data format	DCC and MM
Feedback log	RailCom and RailCom plus
Supply voltage	Digital voltage: 12-24 V  LD-G-31 plus: 12-18 V Analogue voltage: max. 18 V
Current consumption (without connected loads) max.	40 mA
Output for servo (except LD-G-31 plus) max. current for servo output	1 5 mA
Output for loudspeaker Playback Impedance Rated load-carrying capacity	1 mono $\geq 8 \text{ Ohm}$ $\geq 0,1 \text{ Watt}$
Number of switching inputs	2
Connection for buffer capacitor Capacity: - for LD-G-31 plus - for LD-G-33, LD-G-34, LD-G-36 plus Proof voltage - in analogue a.c. layouts	1 $100 \text{ to } 470 \mu\text{F}$ $220 \text{ to } 1.000 \mu\text{F}$ $\geq 25 \text{ V}$ $\geq 35 \text{ V}$
Interfaces depending on the decoder type and the version	according to NEM 652, 658, 660 or 21-pole (similar to NEM 660); SUSI (except LD-G-31)
Protected to	IP 00
Ambient temperature in use	0 ... +60 °C
Ambient temperature in storage	-10 ... +80 °C
Comparative humidity allowed	max. 85 %

		Max. total current [mA]	Max. current for motor [mA]	Number of outputs	Max. current / output [mA]	Max. current / output [mA]	Dimensions PCB [mm]	Weight [g]
LD-G-31 plus	without wires	1 200	600	4	300	---	19.5x9x4.5	1,0
	NEM 652	1 200	600	4	300	---	19.5x9x4.5	3,0
	PluX12	1 200	600	4	300	---	19.5x9x7.5	1,2
LD-G-33 plus	without wires	1 500	1 000	9	F0f, F0r, AUX1 – AUX6: 500	AUX7: 100	25.5x15.5x5	2,0
	NEM 652	1 500	1 000	9	F0f, F0r, AUX1 – AUX6: 500	AUX7: 100	25.5x15.5x5	5,0
	PluX22	1 500	1 000	9	F0f, F0r, AUX1 – AUX6: 500	AUX7: 100	25.5x15.5x7.5	2,5
	21MTC	1 500	1 000	8	F0f, F0r, AUX1, AUX2: 500	AUX3 -AUX6: 10	25.5x15.5x5	2,2
	21-pole	1 500	1 000	8	F0f, F0r, AUX1 – AUX4 500	AUX5, AUX6: 10	25.5x15.5x5	2,2

		Max. total current [mA]	Max. current for motor [mA]	Number of outputs	Max. current / output [mA]	Max. current / output [mA]	Dimensions PCB [mm]	Weight [g]
LD-G-34 plus	without wires	3 000	3 000	8	500	---	27x17x6	3,0
	with wires	3 000	3 000	8	500	---	27x17x6	5,0
	NEM 652	3 000	1 500	8	500	---	27x17x6	6,0
LD-G-36 plus	without wires	1 500	1 000	9	F0f, F0r, AUX1 - AUX6: 500	AUX7: 100	34.5x16x6	3,2
	NEM 652	1 500	1 000	9	F0f, F0r, AUX1 - AUX6: 500	AUX7: 100	34.5x16x6	5,2
	PluX22	1 500	1 000	9	F0f, F0r, AUX1 - AUX6: 500	AUX7: 100	34.5x16x6	3,5
	21MTC	1 500	1 000	8	F0f, F0r, AUX1, AUX2: 500	AUX3 -AUX6: 10	30x15.5x5	3,2
	21-pole	1 500	1 000	8	F0f, F0r, AUX1 - AUX4: 500	AUX5, AUX6: 10	30x15.5x5	3,2

6. Connections



Note the following comment in order to protect the decoder from (maybe irreparable) damage!

Avoid all conducting connections between the decoder and accessories connected to the decoder's common return conductor for all function outputs on the one hand and metal parts of the vehicle or the rails on the other hand. Connections result for example from badly isolated connecting wires (as well as at the stripped ends of connecting wires not in use) or insufficient fixing and isolating the decoder or the accessory, for example. Risk of short circuit! In this case the overload protection of the decoder is not able to protect the decoder from damage.

Before connecting the motor, lighting or other accessories check if the current is below the maximum permissible values and the total current is below the safe load. Should the permissible current be exceeded, this can result in damage to the decoder. Exceeding the motor current or the permissible total current of decoders with overload protection, will lead to switching off the decoder.

You should under no circumstances connect the decoder's common return conductor for all function outputs to vehicle ground. Risk of short circuit!

Old analogue driving transformers (e.g. models in a blue housing from Märklin**) are not suitable for use with digital decoders in analogue operation! These transformers have been designed for the older supply voltage of 220 V and, due to construction, generate very high excess voltage impulses when changing the driving direction. When using them with the modern supply voltage of 230 V too high excess voltage impulses can occur, damaging electronic parts on the decoder. For that reason only use driving transformers designed for a net voltage of 230 V.

6.1. Connector pin assignment LD-G-31 plus (PluX12)

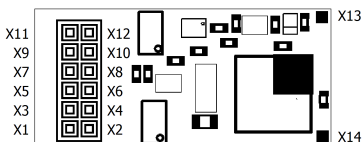
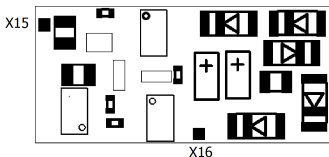
Versions:**PluX12 (NEM 658), 8-pole plug (NEM652), without wires**LD-G-31 plus
- Front side -LD-G-31 plus
- Back side -

Front side	Colour of wire	Connection to (for use of settings in state of delivery)
X1	white	F0f = lighting forward motion (function key F0)
X2	orange	Motor connection 1 (plus)
X3	blue	RL = common return conductor for all function outputs (+)
X4	grey	Motor connection 2 (minus)
X5	---	Index, not occupied
X6	red	Right current collector (or slider)
X7	yellow	F0r = lighting backward motion (function key F0)
X8	black	Left current collector (or vehicle ground)
X9	brown	Loudspeaker connection A (signal / -)
X10	green	AUX1 (function key F1)

Front side	Colour of wire	Connection to (for use of settings in state of delivery)
X11	brown	Loudspeaker connection B (+)
X12	violet	AUX2 (function key F2)
X13	grey	Switching input IN1
X14	grey	Switching input IN2

Back side	Colour of wire	Connection to
X15	brown	Negative pole (-) of buffer capacitor; Earth connection for reed contacts / Hall sensors
X16	blue	Positive pole (+) of buffer capacitor; Supply voltage for Hall-Sensor

6.2. Connector pin assignment LD-G-33 plus (PluX22)

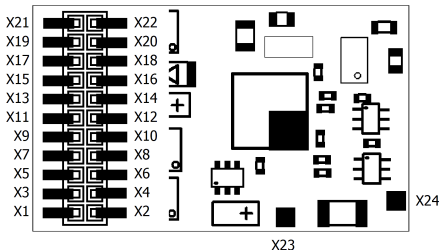
Versions:**PluX22 (NEM 658), 8-pole plug (NEM652), without wires**

LD-G-33 plus
with PluX22-interface
- front side -

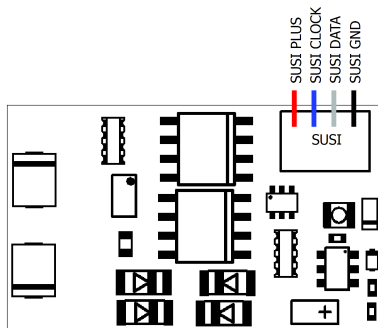

LD-G-33 plus
mit PluX-Schnittstelle
- back side -

Front side	Colour of wire	Connection to (for use of settings in state of delivery)
X1	orange	Servo output
X2	white	AUX3 (function key F5)
X3	grey	SUSI CLOCK or switching input IN1
X4	grey	SUSI DATA or switching input IN2

Front side	Colour of wire	Connection to (for use of settings in state of delivery)
X5	brown	Earth connection for reed contacts / Hall sensors;
X6	blue	Positive pole (-) of buffer capacitor; Supply voltage for Hall sensors
X7	white	F0f = lighting forward motion (function key F0)
X8	orange	Motor connection 1 (plus)
X9	blue	RL = common return conductor for all function outputs (+)
X10	grey	Motor connection 2 (minus)
X11	---	Index, not occupied
X12	red	Right current collector (or slider)
X13	yellow	F0r = lighting backward motion (function key F0)
X14	black	Left current collector (or vehicle ground)
X15	brown	Loudspeaker connection A (signal / -)
X16	green	AUX1 (function key F1)
X17	brown	Loudspeaker connection B (+)
X18	violet	AUX2 (function key F2)
X19	white	AUX4 (function key F6)
X20	white	AUX5 (function key F10)
X21	white	AUX6 (function key F11)
X22	white	AUX7 (function key F13)
X23	orange	Servo output (alternative to X1)
X24	brown	Negative pole (-) of buffer capacitor; Earth connection for servo

6.3. Connector pin assignment LD-G-33 plus (21MTC, 21-pole)

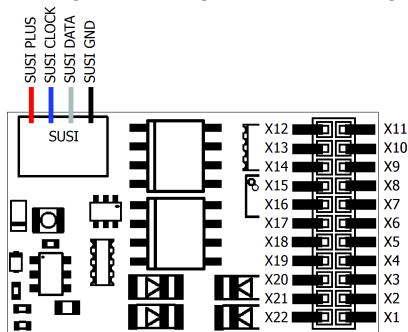
Versions: 21MTC (NEM 660)**and 21-pole socket (similar to 21 MTC)**

LD-G-33 plus
with MTC-interface or
21-pole interface
- front side -

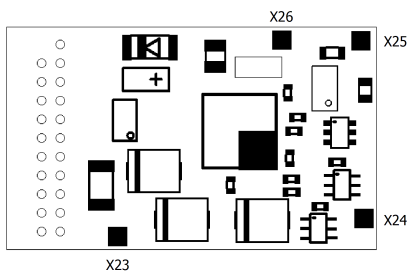

LD-G-33 plus
with MTC-interface or
21-pole interface
- back side -

Front side	Colour of wire	Connection to (for use of settings in state of delivery)
X1/X2	---	Not occupied
X3 *3	white	AUX6 (function key F11) *3
X4 *3	white	AUX4 (function key F6) *3
X5	grey	SUSI CLOCK or switching input IN1
X6	grey	SUSI DATA or switching input IN2

Front side	Colour of wire	Connection to (for use of settings in state of delivery)
X7	yellow	F0r = lighting backward motion (function key F0)
X8	white	F0f = lighting forward motion (function key F0)
X9	brown	Loudspeaker connection A (signal / -)
X10	brown	Loudspeaker connection B (+)
X11	---	Index, not occupied
X12	---	Internal decoder voltage VCC: not intended for external connection
X13 *3	white	AUX3 (function key F5) *3
X14	violet	AUX2 (function key F2)
X15	green	AUX1 (function key F1)
X16	blue	RL = common return conductor for all function outputs (+); Supply voltage for Hall sensors
X17 *3	white	AUX5 (function key F10) *3
X18	grey	Motor connection 2 (minus)
X19	orange	Motor connection 1 (plus)
X20	brown	Earth connection for reed contacts / Hall sensors
X21	black	Left current collector (or vehicle ground)
X22	red	Right current collector (or slider)

Back side	Colour of wire	Connection to (for use of settings in state of delivery)
X23	blue	Positive pole (+) of buffer capacitor
X24	brown	Negative pole (-) of buffer capacitor
X25	orange	Servo output
X26	brown	Earth connection for servo

*3 Max. current	21 MTC (NEM 660)	21-pole
AUX3 / AUX4	10 mA (not boosted)	500 mA (boosted)
AUX5 / AUX6	10 mA (not boosted)	10 mA (not boosted)

6.4. Connector pin assignment LD-G-34 plus

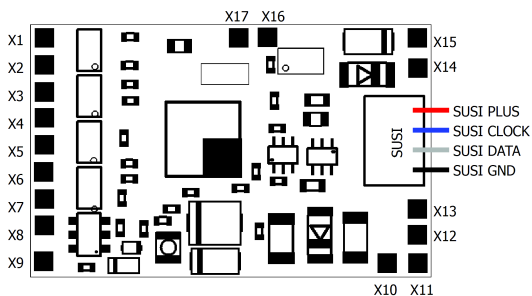
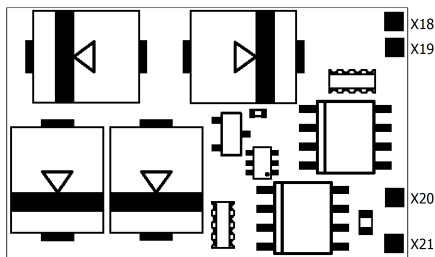
Versions: without / with wires, 8-pole plug (NEM652)LD-G-34 plus
- Front side -LD-G-34 plus
- Back side -

Front side	Colour of wire	Connection to (for use of settings in state of delivery)
X1	white	F0f = lighting forward motion (function key F0)
X2	yellow	F0r = lighting backward motion (function key F0)
X3	green	AUX1 (function key F1)
X4	violet	AUX2 (function key F2)
X5	white	AUX3 (function key F5)
X6	white	AUX4 (function key F6)
X7	white	AUX5 (function key F10)
X8	white	AUX6 (function key F11)
X9	blue	RL = common return conductor for all function outputs (+)
X10	orange	Servo output
X11	brown	Earth connection for reed contacts / Hall sensors
X12	brown	Negative pole (-) of buffer capacitor; Earth connection for servo
X13	blue	Positive pole (+) of buffer capacitor; Supply voltage for Hall sensors
X14	brown	Loudspeaker connection B (+)
X15	brown	Loudspeaker connection A (signal / -)
X16	grey	Switching input IN2
X17	grey	Switching input IN1

Back side	Colour of wire	Connection to (for use of settings in state of delivery)
X18	red	Right current collector (or slider)
X19	black	Left current collector (or vehicle ground)
X20	grey	Motor connection 2 (minus)
X21	orange	Motor connection 1 (plus)

	Colour of wire	Connection to (for use of settings in state of delivery)
X3	grey	SUSI CLOCK
X4	grey	SUSI DATA
X5	brown	Negative pole (-) of buffer capacitor; Earth connection for reedcontacts / Hall-sensors
X6	blue	Positive pole (+) of buffer capacitor
X7	white	F0f = lighting forward motion (function key F0)
X8	orange	Motor connection 1 (plus)
X9	blue	RL = common return conductor for all outputs (+)
X10	grey	Motor connection 2 (minus)
X11	---	Index, not occupied
X12	red	Right current collector (or slider)
X13	yellow	F0r = lighting backward motion (function key F0)
X14	black	Left current collector (or vehicle ground)
X15	brown	Loudspeaker connection A (signal / -)
X16	green	AUX1 (function key F5)
X17	brown	Loudspeaker connection B (+)
X18	violet	AUX2 (function key F6)
X19	white	AUX4 (function key F10)
X20	white	AUX5 (function key F11)
X21	white	AUX6 (function key F13)
X22	white	AUX7 (function key F14)
X23	brown	Earth connection for sound clock generator (reedcontact or Hall-sensor)
X24	blue	Voltage supply for sound clock generator (Hall-Sensor)
X25	grey	Input for sound clock generator (reedcontact or output Hall-sensor)

6.6. Connector pin assignment LD-G-36 plus (21MTC, 21-pole)

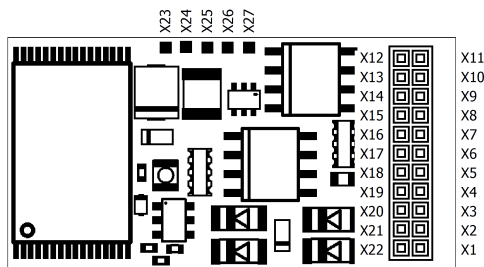
Versions: 21MTC (NEM 660)**and 21-pole socket (similar to 21 MTC)**

LD-G-36plus
with MTC-interface
or 21-pole interface
- Front side -



LD-G-36plus
with MTC-interface
or 21-pole interface
- Back side -

Front side	Colour of wire	Connection to (for use of settings in state of delivery)
X1/X2	---	Not occupied
X3 *4	white	AUX6 (function key F11) *4
X4 *4	white	AUX4 (function key F6) *4
X5	grey	SUSI CLOCK
X6	grey	SUSI DATA
X7	yellow	F0r = lighting backward motion (function key F0)
X8	white	F0f = lighting forward motion (function key F0)
X9	brown	Loudspeaker connection A (signal / -)
X10	brown	Loudspeaker connection B (+)
X11	---	Index, not occupied
X12	---	Internal decoder voltage VCC: not intended for external connection
X13 *4	white	AUX3 (function key F5) *4
X14	violet	AUX2 (function key F2)
X15	green	AUX1 (function key F1)
X16	blue	RL = common return conductor for all function outputs (+)
X17 *4	white	AUX5 (function key F10) *4
X18	grey	Motor connection 2 (minus)
X19	orange	Motor connection 1 (plus)
X20	brown	Earth connection for reed contacts / Hall-sensors
X21	black	Left current collector (or vehicle ground)
X22	red	Right current collector (or slider)



Front side	Colour of wire	Connection to (for use of settings in state of delivery)
X23	red	SUSI PLUS; Positive pole (+) of buffer capacitor
X24	blue	SUSI CLOCK or switching input IN1
X25	grey	SUSI DATA or switching input IN2
X26	black	SUSI GND; Negative pole (-) of buffer capacitor
X27		Not intended for external connection

Back side	Colour of wire	Connection to (for use of settings in state of delivery)
X28	grey	Supply voltage for sound clock generator (reedcontact or output Hall-sensor)
X29	brown	Earth connection for sound clock generator / servo (reedcontact, Hall-sensor, servo)
X30	blue	Voltage supply for for sound clock generator (Hall-Sensor)
X31	orange	Servo output

*4 Max. current	21 MTC (NEM 660)	21-pole
AUX3 / AUX4	10 mA (not boosted)	500 mA (boosted)
AUX5 / AUX6	10 mA (not boosted)	10 mA (not boosted)

6.7. Using decoders with interface connectors

Many recent locomotives with d.c. motor are equipped ex works with an interface socket or an interface plug. Using a decoder with a suitable connector saves separating the connections and soldering works at the locomotive. Possible versions:

	Description	Number of poles	MOROP standard
	8 pole	8	NEM 652
	PluX12,-16,-22 (Fig.: PluX12)	11, 15 oder 21	NEM 658
	21MTC	21	NEM 660 (2 boosted outputs)
21 pole (similar to 21MTC)	21-pole	21	--- (4 boosted outputs)

The interface enables you to connect the decoder to the motor, the rail current collectors, the lighting and – provided the special connector is designed for it – additional accessories.

When mounting decoders with 6-pole interface connectors according to NEM 651 or 8-pole interface connectors according to NEM 652, take care to put the markings on the connector and on the socket on top of each other. The PluX-connectors according to NEM 658 and 21MTC-connectors according to NEM 660 can be mounted in one direction only.

You can use a decoder with PluX12 interface connector in a locomotive with PluX16 or PluX22 interface as well. All functions provided by the decoder are available then.

Hint:

There are locomotives available that have interfaces physically going up to the 21MTC interface, but not having 2 boosted outputs (corresponding to NEM 660) but 4 boosted outputs. Only locomotives made corresponding to NEM 660 are allowed to be labelled with the 21MTC logo.

Please check on the package and in the manual of your locomotive whether the interface corresponds to NEM 660 or not and use the suitable decoder version.

6.8. Use in locomotives with a.c. motor

The locomotive decoders of the series 30 plus have been designed to control direct current (d.c.) motors, for that reason they cannot be connected directly to alternating current (a.c.) motors. You can control a.c. motors with the locomotive decoders of the series 30 plus and benefit of the load control when

- mounting a load control adapter between a.c. motor and decoder or
- replacing the field coil of the a.c. motor by a permanent magnet.

6.9. INFO: Earth connections and voltage outputs

Most locomotive decoders of the series 30 plus have several earth connections (-) as well as voltage outputs (+). In the connection lists the connections for the return conductors of the accessories, for the servos, reed contacts and Hall sensors and the buffer capacitors are specified as they are most practicable for usual assignment. You can choose another assignment of the earth connections (-) and the voltage outputs if necessary.

	Possible assignments to earth connections (-)	Possible assignments to voltage outputs(+)
Return conductor of the accessories	---	Common return conductor for all function outputs
Buffer capacitor	negative pole	positive pole
Reed contacts	earth connection	---
Hall sensors	earth connection	supply voltage
Servo	earth connection	--- Hint: You need an external supply voltage for the servos!

6.10. Mounting decoders without interface

Locate the position for the decoder after opening the locomotive housing. Disconnect the motor from the rail current collectors or the change-over switch from the motor and rails if you have a locomotive with electronic change-over switch. The change-over switch is no longer necessary, you can remove it.



Caution:

The interference suppression devices mounted to the motor or the connecting wire must not be removed! Motor and interference suppression devices are one unit. If even one part is removed, it can cause extreme interference!

Connecting the decoder to the motor

Connect the decoder to the rail current collectors and to the motor. Should the locomotive's direction of motion in analogue mode not match the direction of motion set at the speed control you have to swap the connections to the rail current collectors / the slider.

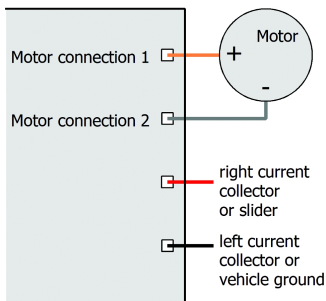
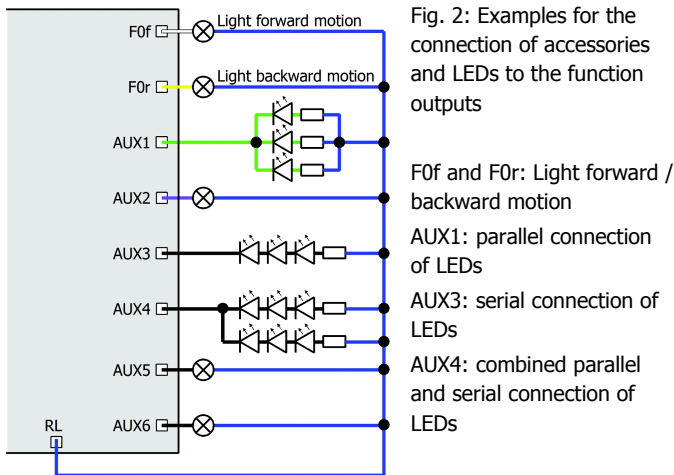

Fig. 1: Connection of the motor and the power supply

Connecting accessories to the outputs

Disconnect any existing diodes in the leads to the lamps, otherwise the lamps might not light. Connect the lamps and the accessories to the function outputs of the decoder. If the lamp or the accessory is already connected with one side to vehicle ground, the connection is complete. If not, connect the second side of the lamp or the accessory to the decoder's common return conductor for all function outputs.

You find the factory (default) settings in the lists with the connector pin assignments. You can assign the outputs to the function keys voluntarily by setting the configuration variables.



Attention: The examples of connection are suitable to only a limited extent for the decoders with 21MTC and 21 pole interface. With the decoders with 21MTC interface AUX3 to AUX6 and with the decoders with 21 pole interface AUX5 and AUX6 have a capacity of only 10 mA!

6.11. Connecting LEDs to the function outputs

The decoder's function outputs switch respective to the decoder ground. For that reason you must connect the cathodes (-) of the LEDs to the function outputs and the anodes (+) to the decoder's common return conductor for all function outputs.



Caution:

If you use light-emitting diodes (LEDs) you must always operate them via a series resistor, otherwise they will be damaged when put into operation or their duration of life will be reduced considerably!

When doing without a series resistor, other components undertake the series resistor's function (e.g. rails, wheels, current connectors), possibly leading to a modification of the data signal and thus to disturbances in digital operation.

Always determine the necessary series resistor's value for the peak value of the available operating voltage. With regulated boosters this corresponds to the specified boosters' output (= track) voltage. With not regulated boosters or analogue driving transformers the peak value is approx. 1,4 fold the nominal voltage specified on the transformer.

Serial connection of LEDs

When you want to connect several LEDs to one output you can switch them in series via a common series resistor. The current consumption is max. 20 mA for all LEDs, depending on the series resistor's value. The maximum number of LEDs to be connected in series results from

$$\frac{\text{Peak value of the operating voltage}}{\text{- sum of the forward voltages of all LEDs}} > 0$$

The advantage of this solution is the low current consumption.

In order to determine the necessary series resistor for a serial LED's

connection first add the forward voltages of all LEDs. The forward voltages depend on the lighting colour and should be given in the technical specifications. In case there is no manufacturer information available, you can take as a basis 4 V for white and blue LEDs and 2 V for yellow, orange, red and green LEDs.

The remaining voltage has to be "eliminated" by a resistor. The formula for the calculation of the resistor is:

$$\text{required } R_V [\text{Ohm}] = (U_B [\text{V}] - \sum U_F [\text{V}]) / (I_F [\text{mA}] \times 0.001)$$

U_B = operating voltage (peak value) | $\sum U_F$ = sum of the forward voltages of all LEDs

I_F = current with max. luminosity

Parallel connection of LEDs

Alternatively, you can connect several LEDs in parallel, each via a series resistor of its own. The current consumption is max. 20 mA for all LEDs, depending on the series resistor's value. The maximum number of LEDs to be connected in parallel results from

maximum current at the output

- sum of the current consumption of all LEDs

> 0

Advantageous with this solution is that the LEDs already lighten when their forward voltage has been reached (2 to 4 V, depending on the fluorescent colour), which makes this solution suitable for analogue mode. Disadvantageous is the high current consumption.

The formula for the calculation of the resistor is:

$$\text{required } R_V [\text{Ohm}] = (U_B [\text{V}] - U_F [\text{V}]) / (I_F [\text{mA}] \times 0.001)$$

U_B = operating voltage (peak value) | U_F = forward voltage of the LED

I_F = current with max. luminosity

In order to save current, you can limit the LEDs' current consumption to 10 mA, which normally does not cause a visible loss of luminance.

6.12. Connecting inductive loads

When connecting inductive loads (e.g. TELEX couplings, relays or other accessories with coils), you should switch a free-wheeling diode (e.g. 1N400x) in parallel, in order to avoid damage at the output. Check to connect the anode of the diode to the function output.

6.13. Connecting accessories via a relay

When you want to switch an accessory / accessories via the decoder, which connection would lead to exceeding the maximum current at the output or of the decoder, you can switch the accessories via a relay (e.g. 1xUm 1A 12V, item-no. 84-61010) and connect them directly to the vehicle's current collector.

The current consumed by the relay depends on its type. The relay named in the example needs approx. 100 mA.

As described in the section "Connecting inductive loads" you should switch a free-wheeling diode (e.g. 1N400x) in parallel to the relay.

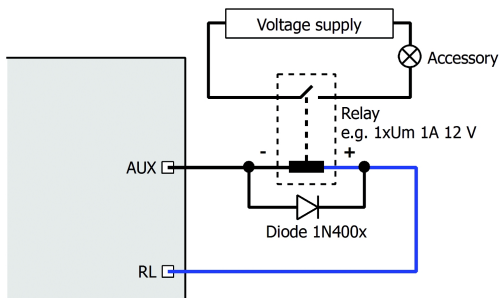

Fig. 3: Connection of an accessory via a relay

6.14. Connecting a loudspeaker

Use a loudspeaker with an impedance of at least 4 Ohm. When connecting a loudspeaker with a lower impedance, the output for the loudspeaker will be damaged. As a rule the playback quality increases with the loudspeaker's size. For that reason you should choose a loudspeaker as large as possible.

In addition, the correct mounting of the loudspeaker is decisive for the sound reproduction. The loudspeaker membrane should emit directly to the outside, the other side into the inside of the vehicle which should be as airtight as possible. The larger the volume in the inside, the better is the reproduction quality. Suitable for the mounting are e.g. the bottom of the vehicle or the back of the driver's cab.

Clearing disturbances of the sound reproduction

As a matter of principle the sound playback can be distorted or disturbed by a high whistling noise. In this case you should solder a suppression choke ($\geq 470 \mu\text{H}$ / 90 mA) into one of the supply wires of the loudspeaker (except with the LD-G-36 plus).

Disturbing noises can occur with a bad current draw (e.g. due to dirty rails or at points) and with RailCom switched on. You can remedy these disturbances by mounting a buffer capacitor.

6.15. Connecting a buffer capacitor

In sections with bad contact to the rails the power supply of the decoder can be interrupted. Possible consequences are e.g. flickering lighting or disturbing noises from the loudspeaker. In these and similar cases you can find a remedy by connecting a buffer capacitor.

The electrolytic capacitor should have a capacity of minimum 100 μF (LD-G-31 plus) or 220 μF and a proof voltage of minimum 25 V. When used in analogue a.c. layouts, a voltage of minimum 35 V is required. Observe the correct polarity when connecting the capacitor!

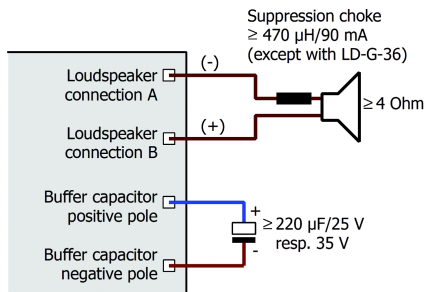

Fig. 4: Connection of a buffer capacitor to improve the voltage supply and of a suppression choke at the loudspeaker

6.16. Connecting a servo (not with LD-G-31)

Connect the signal input of the servo to servo output and the earth connection of the servo to an earth connection of the decoder. The voltage supply for the servo should not be taken from the decoder, as the decoder cannot supply the current needed to control the servo. For that reason you need an external voltage supply for the servo (e.g. servo PCB item no. 70-05900).

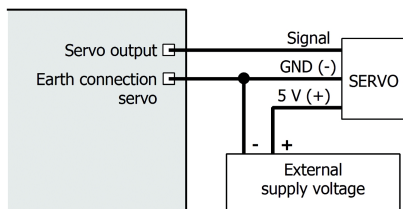

Fig. 5: Connecting a servo

6.17. Connecting the switching inputs

Depending on the decoder type and layout you can connect components to be used to trigger the switching inputs (e.g. reedcontacts or Hall sensors) either directly to the soldering points or via the SUSI interface. With the decoder versions equipped with a SUSI plug (LD-G-33 plus and LD-G-36 plus in the PluX version), you need a SUSI socket with wire for the connection of the switching inputs (e.g. item no. 70-01111).

	Versions	Soldering points	SUSI-interface
LD-G-31 plus	all	X13 X14	---
LD-G-33 plus * ⁵	without wires, NEM652-plug	X3 X4	via SUSI-socket
LD-G-33 plus * ⁵	PluX22, 21 MTC, 21-pole		via SUSI-socket
LD-G-34 plus	all	X16 X17	---
LD-G-36 plus * ⁵	PluX22, without wires, NEM652-plug	---	via SUSI-socket
LD-G-36 plus * ⁵	21 MTC, 21-pole	---	Soldering points X24, X25

*⁵ With the LD-G-33 plus you can either use the switching inputs or connect a SUSI module. With the LD-G-36 plus you can simultaneously use the switching inputs and connect a SUSI module, the SUSI module has to be connected to the appropriate connections of the PluX interface in this case.

The switching inputs switch respective to the decoder ground and thus can be connected to all (external) circuits allowing to make contact to

earth. It is possible to connect reed contacts or Hall sensors, for example, which make contact to earth when getting into the magnetic field of a permanent magnet.

You can switch the switching inputs respective to the decoder mass as an alternative. In this case you have to solder a resistor (3,3 kOhm) into the connection between switching input and earth of the rails.

Connect the reed contacts to the switching inputs and an earth connection of the decoder. Reed contacts are not polarized, you can assign the two contacts voluntarily.

When connecting Hall sensors check for the correct polarity. Connect the earth connection of the Hall sensor to an earth connection of the decoder, the connection for the voltage supply to a voltage output of the decoder and the output to one of the switching inputs.

⚠ When exchanging the earth connection for the connection of the voltage supply, the Hall sensor can be damaged!

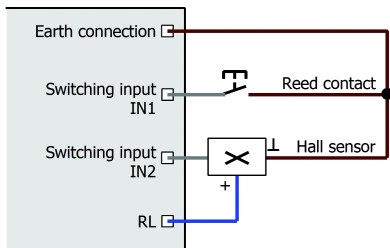

Fig. 6: Connection of reed contacts and Hall sensors to the switching inputs

Assigning the connections when using the SUSI interface:

SUSI PLUS	Supply voltage for reed contacts or Hall sensors
SUSI CLOCK	Switching input IN1
SUSI DATA	Switching input IN2
SUSI GND	Earth connection for reed contacts or Hall sensors

6.18. Connecting a SUSI module (except LD-G-31 plus)

The SUSI interface is a standardized interface for the connection of accessory modules to a vehicle decoder. Controlling the SUSI module has to be carried out by the vehicle decoder. In order to make the necessary settings for the SUSI module you have to program the decoder.

The decoder (except LD-G-36 plus with 21MTC- or 21-pole interface) has a soldered SUSI-plug, fit to insert the socket of the SUSI module. With the LD-G-36 plus with MTC- or 21-pole interface you can solder a SUSI module on the soldering pads provided for that purpose.

There are connections according to SUSI integrated in the 21MTC-and the PluX22 interface, as well. Only the decoder versions without PluX-plugin or MTC-socket are suitable for connecting an external SUSI module to these connecting points.

Please note, that with the locomotive decoder LD-G-33 plus you can either connect a SUSI module or use the switching inputs. With the decoders LD-G-34 plus and LD-G-36 plus you can both connect a SUSI module and use the switching inputs.

6.19. Connecting a clock generator to the LD-G-36 plus

You can control for example the correct synchronisation of the steam discharge with the wheel movements. For that purpose connect a reed contact or a Hall sensor as a clock generator and fix two or more mini magnets to the wheels. When connecting a Hall sensor observe the right polarity.

6.20. Fixing the decoder

After having finished all connections you should fix the decoder, to avoid short circuits by contact to metal parts of the vehicle, for example. You can use double sided adhesive tape for it, for example.

7. Programming

Programming with DCC central units

You can program the configuration variables (CV) of the decoder from the digital central unit, you can use main track programming as well. See the chapter in the manual of your central unit where the byte wise programming of configuration variables (CVs) (Direct programming) and main track programming (POM) are explained. With central units that allow only register-programming it is not possible to program the decoder.

Programming with Motorola central units

In Motorola format the settings are saved in registers.

Please note: If you use a central unit for both DCC and Motorola format it is recommended to program the decoder in the DCC format. After having finished programming the decoder it is possible to control it in Motorola format as well.

Please note: You should connect a lamp or a LED to at least F0f or F0r before starting to program the decoder with a Motorola central unit, as the decoder shows the status of the programming by flashing the lighting connected to these outputs. The flashing frequency shows, which input the decoder expects:

Slow flashing	Fast flashing
Number of the register to be programmed	Value of the register to be programmed

Put the vehicle on a track oval or a track section connected to the central unit's track output (not to the connection for the programming track). Make sure no other vehicle than the one you intend to program is set on the track as the decoder inside this vehicle might be programmed as well.

Starting the programming mode	Programming the decoder
<ol style="list-style-type: none"> 1. Switch on the central unit or perform a reset at the central unit (pushing "stop" and "go" simultaneously). 2. Set the current decoder address (default value: 3) or the address "80". 3 Set all functions to "off". 4. Push button "stop" → switch off the track voltage. 5. Operate the direction switch and hold it in that position. Push the button "go" at once. 6. As soon as the lighting flashes, release the direction switch. 	<ol style="list-style-type: none"> 1. Enter the number of the register as a Motorola-address. <i>If necessary: with a leading "0".</i> 2. Operate the direction switch. → Lighting flashes faster. 3 Enter the value you want to set into the register (as Motorola-address). 4. Operate the direction switch. → Lighting flashes more slowly. <p style="text-align: center;">Repeat steps 1 – 4 for all registers.</p> <p style="text-align: center;">Push button "stop".</p>
→ Programming mode	→ End of programming mode.

Programming with central units with restricted input options

Some central units do not allow but input values up to 80 or 99. Two auxiliary registers (CV#26 and #30) make it possible to enter higher values.

Programming with the Central Station and the Mobile Station

With the Central Station I or the Mobile Station of Märklin** you can program the registers. Select the article no. 29750 from the locomotive database and program the decoder as described for this article in the Central Station's or Mobile Station's manual.

Programming with the CV-Navi

Instead of programming the configuration variables or registers of the decoder using the digital central unit, you can use the free software CV-Navi. In order to use the software, you need a digital central unit supporting the p50x-protocol (e.g. Tams MasterControl or Intellibox of Uhlenbrock**).

You will find the free download presumably from beginning of 2014 under:

www.tams-online.de

8. Configuration variables and registers

In the lists you will find in the column "No." the numbers of the configuration variables for programming in DCC format. The numbers of the registers for programming in Motorola format are identical to the CV numbers. The defaults are those values set in the state of delivery and after a reset.

Please note: With variables destined to set several parameters, the input value has to be calculated by adding the numerical values assigned to the desired parameters.

Setting the address

Name of CVs / registers	No.	Input value (Default)	Remarks and Tips
Basic address	1	1 ... 255 (3)	Range of values in DCC-Format: 1 ... 127
Tip: If a value higher than 127 is set for the basic address and the use of extended addresses in CV#29 is set to off, the decoder does not react to signals in DCC format!			
Extended address	17	192 ... 255 (192)	Only for DCC format. Most central units permit entering extended addresses directly. The CVs # 17, 18 and 29 are set automatically to the proper values.
	18	0 ... 255 (255)	
Consist address	19	1 ... 127 (0)	= 2nd adress In DCC format only!
2nd Motorola address	47	0 ... 255 (4)	= Address needed to switch additional functions in Motorola format. The function keys F5 to F8 are reached via the function keys F1 to F4, the function key F9 via the function key F0.

Information / Read only

Name of CVs / registers	No.	Input value (Default)	Remarks and Tips
Version	7	---	Read only in DCC format!
Manufacturer	8	--- (62)	Read only in DCC format!
Index for higher CV pages	31	--- (0)	Set firmly. For reading out RailCom relevant data. Only for DCC format.
	32	--- (255)	

Auxiliary functions

Name of CVs / registers	No.	Input value (Default)	Remarks and Tips
Reset	8	0 ... 255	Any input value restores the settings in state of delivery.
Auxiliary register for programming with central units with restricted input options			Allows to enter values > 80 resp. 99 with central units allowing to entries from 0 or 1 to 80 or 99.
	26	(0)	Number of CV
	30	(0)	Value of CV
<p>In CV #26 and 30 you preset the hundred and the tenner for the CV number and CV value. In order to program a CV number > 80 or 99 you have to program the desired "one" value into the CV with the corresponding "one" number. Instead of a "0" you can enter "10" (with those central units not allowing to enter a "0"). Examples:</p>			
CV#137 → value 245 1. CV#26 = 13 (1 = the 100 3 = 10ner) 2. CV#30 = 24 (2 = the 100 4 = 10ner) 3. CV#7 = 5 (7 = the one of the CV number, 5 = the one of the CV value)		CV#120 → value 230 1. CV#26 = 12 (1 = the 100 2 = 10ner) 2. CV#30 = 23 (2 = the 100 3 = 10ner) 3. CV#10 = 0 or 10 (10 for value 0 of the one of the CV number, 0 or 10 for value 0 of the one of the CV value)	

Settings for analogue mode

Name of CVs / registers	No.	Input value (Default)	Remarks and Tips
Packet time out for analogue recognition	11	0 ... 255 (5)	The higher the set value, the longer it takes until the decoder automatically switches to analogue mode after having received the last digital signal .
Analogue mode	12	0, 1 (1)	= Procedure triggering a change of direction Overvoltage impulse (a.c. layouts) 0 Change of polarity (d.c. layouts) 1
Functions active in analogue mode <small>(only for F1 to F8, not for F9 to F12)</small>	13	0 ... 255 (0)	F1 on 1 F2 on 2 F3 on 4 F4 on 8 F5 on 16 F6 on 32 F7 on 64 F8 on 128
Intensity of overvoltage impulse (for analogue a.c. layouts)	199	0 ... 255 (100)	0 = minimum voltage 255 = maximum voltage

Basic settings

Name of CVs / registers	No.	Input value (Default)	Remarks and Tips
RailCom settings	28	0,1,2,3,128,129,130,131 (131)	no feedback 0
			channel 1 on 1
			channel 2 on 2
			RailComPlus on 128
Configuration data 1	29	0 ... 64 (14)	Direction "Standard" 0
			Reverse direction 1
			14 speed levels 0
			28 or 128 speed levels 2
			Analoge recognition off 0
			Analoge recognition on 4
			RailCom off 0
			RailCom on 8
			Linear velocity characteristic 0
			Alternat. velocity charact. 16
Basic addresses 0			
Not for MM mode:			Extended addresses 32
<p>Example: CV#29 = 0. → Direction = "Standard". 14 speed levels. Basic addresses. Automatic analogue recognition = "off". RailCom = "off".</p> <p>Example: CV#29 = 46. → Direction = "Standard". 28 or 128 speed levels in DCC-mode. Automatic analogue recognition = "on". RailCom = "on". Extended addresses.</p> <p>Tip: If the use of extended addresses is activated in CV#29, the decoder does not react to signals in Motorola format!</p>			
Configuration data 2	49	0 ... 255 (73)	Load control inactive 0
			Lastregelung active 1
			Shunting gear at F1 2
			Shunting gear at F2 4
			Shunting gear at F3 8
			Shunting gear at F4 16
			Acceleration and brake delay to be switched at F3 32
Acceleration and brake delay to be switched at F4 64			

Basic settings (continuation)

Name of CVs / registers	No.	Input value (Default)	Remarks and Tips
Switching off at overload <small>(not valid for LD-G-31 plus and LD-G-34 plus)</small>	48	--- (45)	Determines, at which current the overload protection responds. The higher the input value, the higher is the current responding at overload protection. 45 = 1 500 mA The value of 45 should be altered as an exception only!

Setting the driving of the motor

Name of CVs / registers	No.	Input value (Default)	Remarks and Tips
Starting voltage (Starting velocity)	2	0 ... 255 (6)	= The voltage to be output to the motor at speed level 1. 0 = 0 Volt 255 = max. voltage
Acceleration rate	3	0 ... 255 (10)	= Length of the delay before the switching to the next
Braking rate	4	0 ... 255 (5)	higher / lower speed level when the locomotive is accelerating / braking. The delay is calculated as follows: (value of CV#3) x 0,9 sec. / number of speed levels
Maximum voltage (maximum velocity)	5	0 ... 255 (255)	= The voltage to be output to the motor at the highest speed level. 2 = 0,8 % of the max. voltage 255 = maximum voltage

Setting the driving of the motor (continuation)

Name of CVs / registers	No.	Input value (Default)	Remarks and Tips
Medium voltage (Medium velocity)	6	0 ... 255 (100)	=The voltage to be output to the motor at the medium speed level. 2 = 0,8 % of the max. voltage 255 = maximum voltage
Motor frequency	9	0 ... 255 (0)	=Frequency controlling the motor: 0 = 30 kHz 255 = 58 Hz For values > 0: frequency [Hz] = 30.000 / (2 x value of CV#9)
Braking performance with d.c. voltage	27	0, 32, 64,96 (0)	No braking with d.c. voltage 0
			Braking with negative d.c. voltage 32
			Braking with positive d.c. voltage 64
<p>Tip: It is standard to switch over into analogue mode when applying a d.c. voltage at the rails. In case that the decoder is run in a layout with a braking route based on applying a d.c. voltage (e.g. Märklin**-braking route), the analogue recognition has to be deactivated (in CV#29) to ensure that the locomotive reacts as expected on the braking route.</p> <p>The setting of the negative or positive d.c. voltage is related to the right rail, as seen in the locomotive's direction of motion.</p>			
Starting-kick	65	0 ... 255 (0)	= short-time increase of motor voltage while starting to clear the breakaway torque.
<p>Example: CV#65 = 6 → The motor voltage while starting is equivalent to the voltage applied in operation at speed level 6 (of 255). It is reduced immediately to the actually set speed level with the braking rate defined in CV#4. Thus, when altering the value for CV#4 it may be necessary to alter CV#65, too.</p>			

Setting the driving of the motor (continuation)

Name of CVs / registers	No.	Input value (Default)	Remarks and Tips
Alternative velocity characteristic (only with mode 28 speed levels)	68 . . 95	0 ... 255	= velocity table for the alternative velocity characteristic. Any motor voltage can be assigned to all of the 28 speed levels. 0 = voltage of "0" 255 = maximum voltage

Setting the load control

Name of CVs / registers	No.	Input value (Default)	Remarks and Tips
Parameter of load control KP	50	0 ... 255 (16)	= Proportional component of the load control.
The parameter KP defines the basic speed. A too small value → locomotive too slow. A too high value → heavy shuttering of the locomotive.			
Parameter of load control KI	51	0 ... 255 (14)	= Integral component of the load control.
The parameter KI provides the fine tuning of the load control. The value has to be adjusted in very small steps. A too high value → heavy shuttering of the locomotive.			
Parameter of load control KD	52	0 ... 255 (8)	= Differential component of the load control.
The parameter KD retards the transforming of the load control. A too small value → shaking of the locomotive. A too high value → rocking of the locomotive.			
Motor adaptation 1	165	0 ... 20 (4)	= Factor multiplying the value of the load control
Motor-adaptation 2	166	0 ... 20 (1)	= Number of averagings of the measured values of the load control

Optimising the CV-settings

Above all, the driving characteristics can be influenced by setting the CV#2 (starting voltage), the CV#6 (medium velocity) and CV#5 (maximum voltage).

In addition, you can alter the parameters of the load control. To adjust the parameters for the load control (CV#50 to #52) the following procedure is recommended:

If the locomotive is shuttering: → Increase the value for CV#52 (KD) in 5-steps. If this does not lead to an improvement of the driving characteristics, set the value of CV#52 back to factory setting (default value). Then decrease the value for CV#50 (KP) in 5-steps and for CV#51 (KI) in 2-steps.

If the locomotive does not have enough power and e.g. gets very slow on the way uphill: → Increase the value for CV#51 (KI) in 2-steps, until the locomotive starts to shutter. Then increase the value for CV#52 (KD) in 5-steps. If this does not lead to an improvement or the locomotive starts to shutter immediately after increasing CV#51, set the values for CV#51 and CV#52 back to factory setting (default value) and increase the value for CV#50 (KP) in 5-steps.

If the locomotive is rocking: → Decrease the value for CV#52 in 5-steps.

If you are not content with the driving characteristics in slow approach, you can influence them by altering CV#166 and CV#165. Start with altering the value of CV#166 in 1-steps.

Tip: Setting the parameters of the load control is very difficult, a change can result in a considerable worsening of the driving characteristics. For that reason you should always alter the values in small steps only. When altering the parameters of the load control does not result in an improvement, you should reset the default values.

Assignment of the outputs to the function keys F0 to F12

Please note: The LD-G-31 plus provides only the outputs F0f, F0r, AUX1 and AUX2.

Name of CVs / registers	No.	Input value (Default)	Remarks and Tips
F0 forward on	33	0 ... 255 (1)	F0f 1
F0 backward on	34	0 ... 255 (2)	F0r 2
F1	35	0 ... 255 (4) LD-G-36: (0)	AUX1 4
F2	36	0 ... 255 (8) LD-G-36: (0)	AUX2 8 AUX3 16
F3	37	0 ... 255 (0)	AUX4 32
F4	38	0 ... 255 (0)	AUX5 64
F5	39	0 ... 255 (16) LD-G-36: (4)	AUX6 128
F6	40	0 ... 255 (32) LD-G-36: (8)	
F7	41	0 ... 255 (0)	
F8	42	0 ... 255 (0)	
F9	43	0 ... 255 (0) LD-G-36: (16)	
F10	44	0 ... 255 (64) LD-G-36: (32)	
F11	45	0 ... 255 (128) LD-G-36: (0)	
F12	46	0 ... 255 (0) LD-G-36: (64)	

Assignment of the outputs to the function keys F13 bis F28

Name of CVs / registers	No.	Input value (Default)	Remarks and Tips
F13	180	LD-G-31: (0)	AUX1 1
		LD-G-33 PluX: (64)	AUX2 2
		LD-G-33 MTC: (0)	AUX3 4
		LD-G-34: (0)	AUX4 8
F14	181	LD-G-36 PluX: (32)	AUX5 16
		LD-G-36 MTC: 0	AUX6 32
...	...	0 ... 127 (0)	AUX7 64
F28	195	0 ... 127 (0)	(not LD-G-33 plus MTC, LD-G-34 plus and LD-G-36 plus MTC)
		Eingabewerte für Decoder ohne AUX7: 0 ... 63	

Assignment of the outputs to the function keys / Default values:

	LD-G-31 plus, LD-G-33 plus and LD-G-34 plus:	LD-G-36 plus:
F0f	F0, switched on at forward motion	
F0r	F0, switched on at backward motion	
AUX1	to be switched with F1	to be switched with F5
AUX2	to be switched with F2	to be switched with F6
AUX3	to be switched with F5	to be switched with F9
AUX4	to be switched with F6	to be switched with F10
AUX5	to be switched with F10	to be switched with F12
AUX6	to be switched with F11	to be switched with F13
AUX7	to be switched with F13	to be switched with F14

Example: F0r to be switched with F5 → CV#39 = 2

Example: F0f and AUX1 3 to be switched with F6 → CV#40 = 5 (= 1+4)

Effects of the outputs

Name of CVs / registers	No.	Input value (Default)	Remarks and Tips
F0f	53	0 ... 255 (0)	Independent of direction 0
F0r	54		AUX off at backward motion 1
AUX1	55		AUX off at forward motion 2
AUX2	56		Function inverted 4
AUX3	57		Flashing inverted 8
AUX4	58		Flashing on 16
AUX5	59		MARsight on 32
AUX6	60		Double flashing on 64
			Kick function on (not for F0f and F0r) 128

Factory settings: The functions F1 to F28 switch the assigned outputs independent of the direction of motion. F0 always switches dependant of the direction of motion.

Examples:

MARsight with F0f, switched on at forward motion: → Input value for CV#53 = 33 (= 1 + 32)

Alternating flashing with AUX2 and AUX3:

→ Input value for AUX2: CV#56 = 16 | Input value for AUX3: CV#57 = 24 (16 + 8)

Settings for the flash lights

Name of CVs / registers	No.	Input value (Default)	Remarks and Tips
Flashing frequency of the lighting			
F0f	104	10 ... 255 (20)	The flashing frequency determines the duration of one period. 10 = highest possible frequency 255 = lowest possible frequency
F0r	105		
AUX1	106		
AUX2	107		
...	...		
AUX6	111		
Flashing frequency of the MARsight for all outputs	112	0 ... 255 (64)	0 = fast 255 = slow

Settings for the flash lights (continuation)

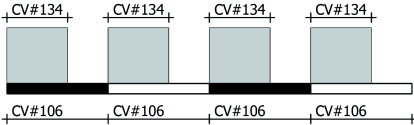
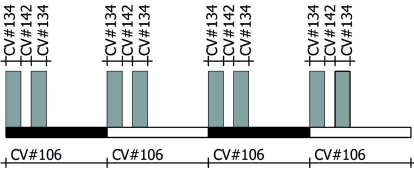
Name of CVs / registers	No.	Input value (Default)	Remarks and Tips
On-time of the flashlights			
F0f	132	0 ... 255 (4)	The maximum value of the on-time is the value set in CV#106 et seq. The higher the input value, the longer is the on-time.
F0r	133		
AUX1	134		
...	...		
AUX6	139		
<p>Example: For AUX1 is set in CV#106 a value of 100 for the flashing frequency and in CV#132 a value of 60 for the on-time.</p>  <p>With a value of 50 in CV#134 on- and off-time would have the same length, with a value of 100 the light would be switched on permanently.</p>			
Double flashing: Length of the break between the two flashlights.			
F0f	140	0 ... 255 (2)	Frequency and on-time have to be set in CV#104 et seq. and CV#132 et seq. The length of the break is the longer the higher the input value is. For the input values for CV#104 et seq., 132 et seq. and 140 et seq. applies: $(CV\#132) \times 2 + (CV\#140) < (CV\#104)$
F0r	141		
AUX1	142		
AUX2	143		
...	...		
AUX6	147		
<p>Example: For AUX1 is set in CV#106 a value of 100 for the flashing frequency and in CV#132 a value of 15 for the on-time. The value for the length of the break in CV#142 is 10.</p>  <p>In case 2 times the value of the on-time + the value of the length of the break would be higher than the frequency, the sequence would be interrupted when reaching the end of the period.</p>			

Dimming of the outputs

Name of CVs / registers	No.	Input value (Default)	Remarks and Tips
F0f	115	1...255 (255)	= Reduction of the voltage applied to the output. "1" = lowest voltage, "255" = maximum voltage
F0r	116		
AUX1	117		
...	...		
AUX6	122		

Dimming of the outputs depending on the speed level

Name of CVs / registers	No.	Input value (Default)	Remarks and Tips	
Internal speed level for CV#114	113	1 ... 255 (10)	= speed level, from which the outputs defined in CV#114 are dimmed with the settings in CV##123 to 126 (instead of settings in CV##115 to 118).	
Outputs dimmed depending on the speed level	114	0 ... 15 (0)	F0f	1
			F0r	2
			AUX1	4
			AUX2	8
			AUX3	16
			AUX4	32
			AUX5	64
AUX6	128			
Dimming depending on the speed level			= reduction of the voltage at the output	
F0f	123	1...255 (255)	"1" = lowest voltage	
F0r	124		"255" = maximum voltage	
AUX1	125		Values are applied to the outputs determined in CV#114 and starting from a speed level determined in CV#113 only.	
...	...			
AUX6	130			

Shunting light

Name of CVs / registers	No.	Input value (Default)	Remarks and Tips
Shunting light	131	0 ... 255 (0)	for F0f 1
			for F0r 2
			for AUX1 4
			for AUX2 8
			for AUX3 16
			for AUX4 32
			to be switched with F3 64
			to be switched with F4 128

Example: For F0r and AUX1 shunting light, to be switched with F4:

→ input value: 134 (= 2 + 4 + 128)

Kick function

Name of CVs / registers	No.	Input value (Default)	Remarks and Tips
Extended kickfunction	160	0 ... 252 (0)	for AUX1 4
			for AUX2 8
			for AUX3 16
			for AUX4 32
			for AUX5 64
			for AUX6 128

When setting the extended kick function for an output, the motor is supplied with power as long as the kick function is switched on.

Example of use: When switching an output via the extended kick function the locomotive runs automatically a little bit nearer to the carriage (in order to ease the burden from the coupling). Afterwards the electric coupling is released via the kick function and the locomotive moves away automatically from the uncoupled carriage.

Voltage at extended kick function	161	0 ... 255 (10)	= Voltage applied to the motor when switching an output via the extended kick function.
Kicking time for direction "forwards" / "backwards"	162 163	0 ... 255 (32)	0 = short 255 = long

Assignment to the switching inputs

Name of CVs / registers	No.	Input value (Default)	Remarks and Tips
Assigning the function outputs to the switching inputs			
IN1	61	0 ... 255 (0)	F0f 1
IN2	63	0 ... 255 (0)	F0r 2
Hint: The switching inputs are released respective to decoder ground. If you want to release them respective to rail ground, you have to mount a resistor (3,3 kOhm). Hint: If you want to trigger sound functions or the servo via the switching inputs, you have to assign them to a function key (CV#62 and #64).			AUX1 4
			AUX2 8
			AUX3 16
			AUX4 32
			AUX5 64
			AUX6 128
Assigning the functions to the switching inputs			
IN1	62	0...255 (0)	F1 1
IN2	64	0...255 (0)	F2 2
The functions are released both via the function keys and the assigned switching input. Hint: The switching inputs are released respective to decoder ground. If you want to release them respective to rail ground, you have to mount a resistor (3,3 kOhm).			F3 4
			F4 8
			F5 16
			F6 32
			F7 64
			F8 128

Setting the minimum on-time of the switching inputs

Name of CVs / registers	No.	Input value (Default)	Remarks and Tips
IN1	177	0 ... 255 (1)	= Length of time for the input to be switched on after having been connected to earth. Increasing the value by "1" will prolong the length of time by 1,1 sec. 0 = 0 sec. (off) 255 = 280.5 sec. (> 4 min.)
IN2	178	0 ... 255 (1)	

Settings for integrated sounds (without LD-G-36 plus)

Name of CVs / registers	No.	Input value (Default)	Remarks and Tips
Assignment of the function keys to the integrated sounds			
F1	148	16,32,64 (0)	Whistle 16
F2	149	16,32,64 (0)	Signal horn 32
F3	150	16,32,64 (0)	Bell 64
F4	151	16,32,64 (0)	
F5	152	16,32,64 (0)	
F6	153	16,32,64 (0)	
F7	154	16,32,64 (16)	
F8	155	16,32,64 (32)	
F9	156	16,32,64 (64)	
F10	157	16,32,64 (0)	
F11	158	16,32,64 (0)	
F12	159	16,32,64 (0)	
You should assign only one sound to each function key.			

Settings for the servo output (except LD-G-31 plus)

Name of CVs / registers	No.	Input value (Default)	Remarks and Tips
Inverting the functions F5 to F12 for the servo output (in combination with CV#167)	164	0 ... 255 (1)	Exchanges left and right stopopf the servo
			Activation with F5 1
			F6 2
			F7 4
			F8 8
			F9 16
			F10 32
			F11 64
			F12 128

Settings for the servo output (Fortsetzung)

Name of CVs / registers	No.	Input value (Default)	Remarks and Tips
Assignment servo output to the function keys	167	0 ... 255 (2)	Allowing the servo to be controlled via POM 0
			Activation with F5 1
			F6 2
			F7 4
			F8 8
			F9 16
			F10 32
			F11 64
			F12 128
Determining the operating mode of the servo output	168	0,1 (0)	Allowing the servo to be controlled via f-keys 0
			Entering the servo folding square via POM 1
Setting the servo			The value for the right stop has to be higher than the value for the left stop.
left stop	169	40...250 (112)	
right stop	170	40...250 (176)	
velocity	171	0 ... 255 (16)	
Controlling the servo via POM / servo position	172	40...250 (restricted by: CV#169 → lowest value and CV#170 → highest value)	The last via POM set value will be saved and the corresponding position will be headed for automatically.
			Note: Controlling the servo via POM is not possible until CV#167 = 0 and CV#168 = 1.

Coupling function

Name of CVs / registers	No.	Input value (Default)	Remarks and Tips	
Time-out for coupling function	96	0 ... 255 (10)	= maximum length of time for the coupling operation (in seconds) before breaking off.	
Function key F1 to F4 and direction for input 1 for input 2	97 99	0 ... 255 (0)	= defines the function key releasing the coupling function and the direction of coupling	
			backwards	0
			forwards	128
			F1	1
			F2	2
			F3	4
			F4	8
Function key F5 to F12 and direction for input 1 for input 2 Hint: Setting the direction of travel in CV##97 and 99	98 100	0 ... 255 (0)	F5	1
			F6	2
			F7	4
			F8	8
			F9	16
			F10	32
			F11	64
F12	128			
Hint: The switching inputs are released respective to decoder ground. If you want to release them respective to rail ground, you have to mount a resistor (3,3 kOhm).				
Motor voltage for coupling function	101	1 ... 255 (16)	0 = minimum voltage (velocity = 0) 255 = maximum voltage (maximum velocity)	

Commuting automatic

Name of CVs / registers	No.	Input value (Default)	Remarks and Tips
Commuting automatic for input 1 for input 2 Hint: It makes sense to assign the terminal stations to input 1 and the additional stops to input 2. (see CV#179)	196 197	0 ... 255 (0)	Stop time = 0 Sek. 0
			Stop time = 5 Sek. 1
			Stop time = 10 Sek. 2
			Stop time = 20 Sek. 4
			Stop time = 40 Sek. 8
			Extending the stop time (x4) 16
			For both directions 32
			For outward journey only 0
			For return journey only 64
			Without change of direction 128

Example: Commuting automatic between two terminal stations with 100 seconds stopping time; releasing via switching input 1: → input value for CV#196: 53 (= 1 + 4 + 16 + 32 + 0)

Example: Additional stops with 30 seconds stopping time, for return journey only; releasing via switching input 2: → input value for CV#197: 198 (= 2 + 4 + 64 + 128)

Switching off the commuting automatic with function key F5 to F12	198	0 ... 255 (0)	F5 1
			F6 2
			F7 4
			F8 8
			F9 16
			F10 32
			F11 64
			F12 128

Switching impulses for input 1 to be ignored	179	0 ... 255 (1)	Prevents, that switching impulses released between the terminal stations release the braking for the terminal station.
--	-----	---------------	--

Hint: Except with very short commuting lines the stops at the two terminal stations are released via separate contacts. In order to prevent the locomotive from stopping immediately after driving back into the opposite direction, you have to program the value "1" in CV#179.

Example: In the example presented under CV##196 and 197 the locomotive is to stop at both terminal stations and alter the direction and stop 3 times during return journey. The stops at the terminal stations are released by separate contacts. Input value for CV#179: 4

Special functions for speed level 0

Name of CVs / registers	No.	Input value (Default)	Remarks and Tips	
Switching off function F0 at speed level 0	173	0...255 (0)	Determines the functions (F1 to F8) to switch off the function F0 at speed level 0.	
			F1	1
			F2	2
			F3	4
			F4	8
			F5	16
			F6	32
			F7	64
F8	128			
Switching on the outputs at speed level 0	174	... 255 (0)	Determines the outputs to be switched on /off / inverted via the functions defined in CV#173 at speed level 0.	
Switching off the outputs at speed level 0	175	0 ... 255 (0)	F0f	1
			F0r	2
Inverting the outputs at speed level 0. off = on on = off	176	0 ... 255 (0)	AUX1	4
			AUX2	8
			AUX3	16
			AUX4	32
			AUX5	64
AUX6	128			

Sound-Update (LD-G-36 plus only)

Name of CVs / registers	No.	Input value (Default)	Remarks and Tips
Sound-Update	103	0, 1 (0)	Update impossible 0
			Update possible 1

Hint: When entering the value "1" for CV#103, no sound will be played back! For that reason you have to set the value for CV#103 back to "0" after a sound-update.

Setting the sound level (LD-G-36 plus only)

Name of CVs / registers	No.	Input value (Default)	Remarks and Tips
Sound level	902	0 ... 255 (128)	0 = off 255 = maximum sound level

Assigning the function keys to the sounds (LD-G-36 plus only)

Name of CVs / registers	No.	Input value (Default)	Remarks and Tips
F0	903	0 ... 8 (0)	No sound 0
F1	904	0 ... 8 (3)	Bell or horn 2 1
F2	905	0 ... 8 (2)	Whistle or horn 1 2
F3	906	0 ... 8 (0)	Standing or driving sound 3
F4	907	0 ... 8 (0)	Decoupling or
F5	908	0 ... 8 (0)	door closing sound 4
F6	909	0 ... 8 (0)	Fader for all sounds 8
F7	910	0 ... 8 (1)	
F8	911	0 ... 8 (8)	
F9	912	0 ... 8 (0)	
F10	913	0 ... 8 (0)	
F11	914	0 ... 8 (4)	
F12	915	0 ... 8 (0)	

Factory settings:

Function key F1 switches sound no. 3 (= standing or driving sound)

Function key F2 switches sound no. 2 (= signal horn1 or locomotive whistle)

Function key F11 switches sound no. 4 (= decoupling or door closing sound)

Function key F7 switches sound no. 1 (= signal horn 2 or bell)

Function key F8 switches fader (= fading in and down) for all sounds

Basic settings for driving sound (LD-G-36 plus only)

Name of CVs / registers	No.	Input value (Default)	Remarks and Tips
Configuration variables	920	0 ... 195 (129)	Exhaust bangs via reed contact only 0
			Exhaust bangs automatically and via reed contact 1
			Break before repeating the whistle 2
			Cutting by half the exhaust bangs 4
			Fading time = 8 seconds and automatic fading when switching on 64
			Power amplifier always switched on * ⁶ 0 Power amplifier off, when sound off * ⁶ 128

Factory settings:

Exhaust bangs automatically and via reed contact: on

Break before repeating the whistle: off

Cutting by half the exhaust bangs: off

Fading time = 8 seconds and automatic fading when switching on: off

Power amplifier off, when sound off

* For the configuration variables, the input values have to be calculated by adding the numerical values assigned to the desired parameters.

⁶ In combination with some types of locomotive types disturbing noises can occur during operation. The decoder can be set to switching the sound power amplifier off when no sounds are released.

Further settings for driving sound (LD-G-36 plus only)

Name of CVs / registers	No.	Input value (Default)	Remarks and Tips
Release threshold at increase of motor load	921	0 ... 128 (3)	0 = change of sound at least increase or decrease of motor load 128 = no change of sound at increase or decrease of motor load
Release threshold at decrease of motor load	922	0 ... 128 (3)	
Switching threshold for ventilator of e-locomotives	923	0 ... 255 (128)	0 = immediate reaction towards changes 128 = ventilator sound / braking sound switched off
Threshold for braking sound	924	0 ... 255 (44)	
Reaction to load changes	925	1 ... 8 (6)	1 = quickest possible reaction 8 = slowest possible reaction
Time of no-load running	937	1 ... 254 (15)	"0" = immediate return in the load mode "255" = no automatic return in the load mode
Adjusting the exhaust bangs to the locomotive's speed level			For operation without clock generator only!
Maximum of exhaust bangs	938	50 ... 255 (0)	
Minimum of exhaust bangs	939	50 ... 255 (0)	

9. Performing a POM-Update

Hint: The POM-Update is possible with decoders from version 2.4 (LD-G-31 plus) or version 2.5 (LD-G-33 plus and LD-G-34 plus). For updating decoders with a former firmware version you have to send them in. The version number is saved in CV #7.

Preparations

1. In order to perform the firmware update you do **not** have to dismount the decoder. Put the vehicle with the mounted decoder on the main track. Hint: You can perform a firmware update with several locomotive decoders of the same type at once, the current software version of the decoders is of no importance. The individual CV settings of the decoder will not be altered by updating.
2. Save the file with the newest firmware on your PC, e.g. LD-G-31_plus_V2_5_0_0.hex for version 2.5.0.0
You can download the newest firmware from our homepage without charge. When getting (on the part of any third parties) a packed file (e.g. *.zip) you have to unpack it first.
3. Get ready the CD with the program "POM-Updater.exe" (included in the delivery) or download the program from our homepage.
4. Connect your central unit with the PC. At present (status: 01/2015) the POM-Update can be carried out with the MasterControl (Tams Elektronik), the Intellibox 1 (Uhlenbrock**) and the CS2 (Maerklin**). You find the current list of central units allowing to perform the POM-update on our homepage.
5. Before starting the update connect at least one lamp or LED to F0f as the update's status is shown by lighting or flashing of the lighting connected to this output.

Changing into the update mode

Execute the programm POM-update.exe, follow the helpfile. Proceed as follows:

1. Make the settings for the update.
2. Enter the addresses of the locomotive decoders you want to update.
3. Change into the update mode.

The lighting connected to the outputs F0f of the decoders which are chosen for an update start to flash slowly. If flashing quickly, the decoder cannot be updated

- because the decoder type does not correspond to the hex-file or
- because the decoder´s firmware already conforms to the version of the hex-file.

The concerned vehicles can stay on the track, they do not affect updating the other decoders. As an alternative you can cut them from current shortly in order to stop them flashing quickly.

Performing the POM-Update

After having changed into the update mode you can start the update. The lighting connected to the outputs F0f of the decoders in update mode stop to flash and show permanent lighting.

The duration of the update depends on the central unit in use and the extent of the transferred data. The progress is shown in the screen mask. As soon as the update has been finished the lighting start to flash slowly. Cut the vehicles from current shortly. Now the vehicles are in standard operation again.

When a fault occurs during updating, the update is interrupted and the lighting starts to flash quickly. In this case restart the update after altering the settings if necessary (see helpfile of the programm for further information).

10. Check list for troubleshooting

- Parts are getting very hot and/or start to smoke.



Disconnect the system from the mains immediately!

Possible cause: one or more connections are soldered incorrectly.
→ Check the connections.

Possible cause: Short circuit between the decoder or accessories connected to the return conductor for all functions and metal parts of the locomotive or the rails. → Check the connections. A short circuit can result in irreparable damage.

Problems with the driving characteristics

- After programming the decoder the locomotive does not run or runs badly.

Possible cause: The set values for the CV are inconsistent.
→ Perform a decoder reset and program the decoder anew.

- In digital mode the locomotive suddenly runs very fast.

Possible cause: Interfering signals from the layout have switched the decoder to analogue mode. → As the origin of the interfering signals' often cannot be found, it is advisable to switch off the automatic recognition of the analogue mode during digital operation. As an alternative you can increase the value for CV#11.

- The CV values cannot be read out by RailCom.

Possible cause: RailCom is switched off. → Alter the value of CV#29 (add "8" to the input value).

- The decoder switches off in operation, switches on after a short time and switches off again immediately.

Possible cause: The overload protection was activated, as the current consumption exceeds the decoder's maximum total current. → Check the current consumption of the motor and the accessories. Possibly the decoder is not suitable for being mounted in this locomotive.

Problems in analogue mode

- The locomotive does not run in analogue mode, the decoder does not work.
Possible cause: The analogue mode is switched off. → Alter the value for CV#29.
- The decoder does not switch to analogue mode (or switches over although it is still digitally controlled).
Possible cause: The value in CV#11 is set too high or too low.
→ Alter the value and check the settings in operation.

Problems with switching of the functions

- An accessory / a light does not react to switching commands.
Possible cause: The accessory is defective or incorrectly connected.
→ Check the accessory / the connections.
Possible cause: The output is defective (e.g. due to overload or short circuit). → Send in the decoder for check / repair (with costs).
- The lighting goes on and off when the speed levels are turned up or the lighting cannot be switched on or off.
Possible cause: The speed mode of the decoder and the digital control unit do not correspond. Example: The central is set to the mode 28 speed levels, but the decoder to the mode 14 speed levels. → Change the speed mode at the central and / or at the decoder.

Problems with switching via switching inputs

- After passing a permanent magnet in the rails no function is activated.
Possible cause: The reed contact or the Hall sensor has been mounted incorrectly. → Check the connections.
Possible cause: The distance to the magnet is too large or the magnet is too weak. → Alter the position of the magnet (if possible) or use a stronger one.

Possible cause: The magnet has been mounted incorrectly polarized.
→ Alter the mounting direction.

Possible cause: The function has been assigned incorrectly to the switching input. → Check the settings in CV## 61 to 64 and 177 and 178.

Problems with the sound playback

- There is no sound to be heard after switching on.

Possible cause: The loudspeaker has been connected incorrectly.
→ Check the connections.

Possible cause (LD-G-36 plus only): The sound level has been set too low in CV#902. → Check the settings.

Possible cause: The decoder is incorrectly connected to the SUSI interface of the sound module. → Check the connections.

- The sound playback is bad, the loudspeaker hums, you can hear disturbing noises. → Mount a buffer capacitor and a suppression choke.

Problems with switching the servo

- The servo does not move.

Possible cause: The left and the right stop are defined incorrectly.
→ Check the settings in CV##169 and 170.

Possible cause: The servo has been mounted incorrectly. → Check the connections.

Possible cause: The power supply is connected incorrectly → Check the connections.

Problems with the POM-Update

- While updating the decoder the lighting starts to flash, the update is interrupted.

Possible cause: The settings for the POM-Update are wrong.
→ Check and alter the settings if necessary. The helpfile contains explanations.

Hotline: If problems with your decoder occur, our hotline is pleased to help you (mail address on the last page).

Repairs: You can send in a defective decoder for repair (address on the last page). In case of guarantee the repair is free of charge for you. With damages not covered by guarantee, the maximum fee for the repair is 50 % of the sales price according to our valid price list. We reserve the right to reject the repairing of a decoder when the repair is impossible for technical or economic reasons.

Please do not send in decoders for repair charged to us. In case of warranty we will reimburse the forwarding expenses up to the flat rate we charge according to our valid price list for the delivery of the product. With repairs not covered by guarantee you have to bear the expenses for sending back and forth.

11. Guarantee bond

For this product we issue voluntarily a guarantee of 2 years from the date of purchase by the first customer, but in maximum 3 years after the end of series production. The first customer is the consumer first purchasing the product from us, a dealer or another natural or juristic person reselling or mounting the product on the basis of self-employment. The guarantee exists supplementary to the legal warranty of merchantability due to the consumer by the seller.

The warranty includes the free correction of faults which can be proved to be due to material failure or factory flaw. With kits we guarantee the completeness and quality of the components as well as the function of the parts according to the parameters in not mounted state. We guarantee the adherence to the technical specifications when the kit has been assembled and the ready-built circuit connected according to the manual and when start and mode of operation follow the instructions.

We retain the right to repair, make improvements, to deliver spares or to return the purchase price. Other claims are excluded. Claims for secondary damages or product liability consist only according to legal requirements.

Condition for this guarantee to be valid, is the adherence to the manual. In addition, the guarantee claim is excluded in the following cases:

- if arbitrary changes in the circuit are made,
- if repair attempts have failed with a ready-built module or device,
- if damaged by other persons,
- if damaged by faulty operation or by careless use or abuse.

12. EU declaration of conformity

 This product conforms with the EC-directives mentioned below and is therefore CE certified.

2004/108/EG on electromagnetic. Underlying standards: EN 55014-1 and EN 61000-6-3 To guarantee the electromagnetic tolerance in operation you must take the following precautions:

- Connect the transformer only to an approved mains socket installed by an authorised electrician.
- Make no changes to the original parts and accurately follow the instructions, connection diagrams and PCB layout included with this manual.
- Use only original spare parts for repairs.

2011/65/EG on the restriction of the use of certain hazardous substances in electrical and electronic equipment (ROHS). Underlying standard: EN 50581.

13. Declarations conforming to the WEEE directive

This product conforms with the EC-directive 2012/19/EG on waste electrical and electronic equipment (WEEE).



DE 37847206

The Tams Elektronik GmbH is registered with the WEEE-no. DE 37847206, according to. § 6 sect. 2 of the German electro regulations from the responsible authority for the disposal of used electro equipment.

Don't dispose of this product in the house refuse, bring it to the next recycling bay.

Information and tips:

<http://www.tams-online.de>

Warranty and service:

Tams Elektronik GmbH

Fuhrberger Straße 4

DE-30625 Hannover

fon: +49 (0)511 / 55 60 60

fax: +49 (0)511 / 55 61 61

e-mail: modellbahn@tams-online.de



DE 37847206

