

Compact Laser Displacement Sensor

HL-G1 Series

Thank you for purchasing products from Panasonic Electric Works SUNX Co., Ltd. Please read this Instruction Manual carefully and thoroughly for the correct and optimum use of this product. Kindly keep this manual in a convenient place for quick reference.

**WARNING**

- This product is intended to detect objects. Do not use it to carry out safety control functions to prevent accidents.
- Never use this product as a sensing device for personnel protection.
- In case of using sensing devices for personnel protection, use products which meet laws and standards, such as OSHA, ANSI or IEC etc., for personnel protection applicable in each region or country.
- Install a fail-safe device in case the product is being used for purposes that can lead to physical injury or serious damage.
- This product cannot be used in an environment containing inflammable or explosive gases.

**Before Use**

Check the sensor head model and package contents before use.



- **Sensor head model**  
Check the model number on the top of sensor head.
- **Package contents**  
Check that all of the following items are included in the package.
  - 1 sensor head
  - 1 Instruction Manual
  - 1 set of laser warning labels

**1 Overview**

This product is a compact laser displacement sensor, incorporating a digital display and controller functions.

- The standard type has three digital outputs and 1 analog output for current or voltage.
- The multifunction type additionally incorporates serial communication functions and can be easily controlled by host devices.
- One out of four measurement distances can be selected for each type that support both NPN and PNP outputs.

**2 Cautions for Handling Laser Light**

In order to prevent accidents caused by laser products and to protect the users, IEC, JIS and FDA established the following standards: These standards classify laser products according to their level of hazard and provide safety measures for the respective classes.

- IEC: IEC 60825-1-2007 (EN 60825-1-2007)
- JIS: JIS C 6802-2005
- FDA: PART 1040 (PERFORMANCE STANDARDS FOR LIGHT-EMITTING PRODUCTS)

**Laser hazard class**

Classification according to IEC 60825-1-2007 (JIS C 6802-2005)

| Class   | Model                       | Description of hazardous evaluation                                |
|---------|-----------------------------|--|
| Class 2 | HL-G1□□-A-C5<br>HL-G1□□-S-J | Visible beam, low power. Blink response of eye affords protection. |

**Warning label and label position**

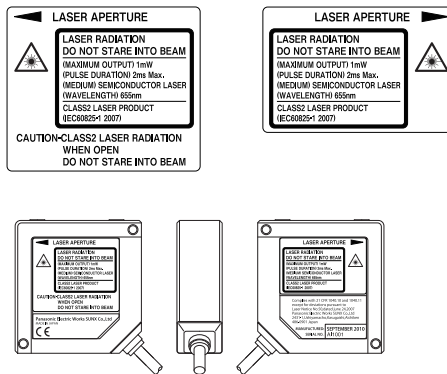

**Installation and operation**

- Install the product so that the laser beam is above or below eye level.
- Do not look into the beam directly during operation. A safe distance from the laser (Nominal Ocular Hazard Distance: NOHD) is approx. 0.4m.
- The laser beam must be terminated at the end of its path by a diffuse reflector or an absorber.
- Please contact Panasonic Electric Works SUNX Co., Ltd. if the system breaks down. It is not equipped with a function that stops laser radiation automatically when the sensor head is being disassembled.
- Do not use the system in any other manner than specified in this instruction manual.

**3 Wiring instructions**

**WARNING**

Turn OFF the power supply before connecting or disconnecting the connectors or performing wiring.

**Connections**

- When connecting or disconnecting the connectors, hold the connector area so that no extra force is applied to the cable.
- Do not touch the terminals or to let foreign objects get into the connectors after disconnecting them.
- Do not apply force around the connector of the sensor head cable or the extension cable. Do not bend the cables near the connectors because the cables will be disconnected.
- When moving the sensor head during operation, install the cables in such a way that they do not bend while the sensor head is moving. Use the multifunction type if bending the cables is inevitable as there are replaceable extension cables available for this type.

**Wiring**

- Do not roll up the sensor cable (bundle in parallel) with other wiring. Keep it at least 100mm away from other wires. Cables should be separated from high voltage and power circuit lines. If this is not possible, shield the cable by running it through conductive material such as grounded electrical conduit.
- Install the product as far away as possible from noise sources such as high-voltage lines, high-voltage devices, power lines, power device, machines which generate a large high-voltage ON/OFF surge, welding machines and inverter motors.
- Do not pull the cable with a force more than 29.4N when wiring the cable when the sensor head is fixed. The cable may be bent with a radius of 30mm or more. However, do not bend the cable within 20mm of the sensor head.

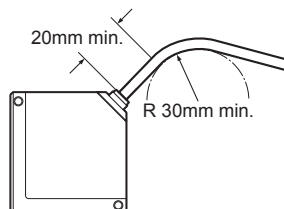

- Make sure that the length of signal and power lines connected to the product is less than 30m in order to meet the CE marking requirements.
- Attach a ferrite core to the head cable as shown.

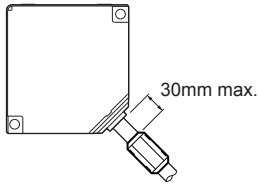

### Warming Up

- Allow the product to warm up for at least 30 minutes after turning on the power to ensure good performance.

### Environment

- Mount the sensor head on an aluminum or steel plate with a minimum surface area of 200cm<sup>2</sup> if the ambient temperature is 40°C or higher. When installing two or more sensor heads in parallel, mount each sensor head on an aluminum or steel plate with a minimum surface area of 200cm<sup>2</sup> and make sure that the ambient temperature does not exceed 40°C.
- The life of the semiconductor laser depends on the ambient temperature during use. When using the product near a heat source, take measures to keep the ambient temperature of the sensor head as low as possible. Mount the sensor on a device that allows heat to dissipate because the sensor itself also generates heat.
- Keep the emitter surface and the receiver surface clean. Prevent light refractors such as water, oil and fingerprints, and light blockers such as dust and dirt from contaminating the surface. When cleaning these parts, wipe them off using a soft lint-free cloth or lens cleaning paper.
- Install the sensor head at a location where external light (such as sunlight or light which has the same wavelength as the laser beam) do not enter the receiver. If high accuracy is required, install a light shield plate or something similar around the sensor head.
- Do not use the product underwater or in the rain. Although the sensor head has an IP67 degree of protection, the connectors are not dust-proof, waterproof, or corrosion-resistant.
- Do not use the product in dusty places or in places that are exposed to flammable or corrosive gases, droplets, direct sunlight, severe vibration or impacts.

## 4 Part Description

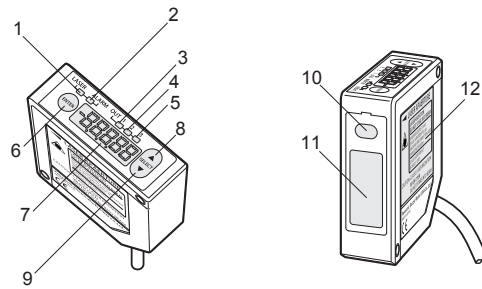

- |                            |                    |
|----------------------------|--------------------|
| 1. Laser Indicator (LASER) | 7. Digital Display |
| 2. Alarm Indicator (ALARM) | 8. [UP] Key        |
| 3. OUT1 Indicator (OUT1)   | 9. [DOWN] Key      |
| 4. OUT2 Indicator (OUT2)   | 10. Emitter        |
| 5. OUT3 Indicator (OUT3)   | 11. Receiver       |
| 6. [ENTER] Key             | 12. Warning Label  |

## 5 Wires

### Analog output wires

| Name  | Function              | Wire color                |       |
|-------|-----------------------|---------------------------|-------|
| A (V) | Analog voltage output | Shielded single conductor | Black |
| AGND  | Analog ground         | Shielded single conductor | Gray  |
| A (I) | Analog current output | Black                     |       |
| AGND  | Analog ground         | White                     |       |

### I/O terminal wires

| Name | Function  | Wire color        |           |
|------|---|-------------------|-----------|
| OUT1 | Judgment output 1   | Gray              |           |
| OUT2 | Judgment output 2   | Pink              |           |
| OUT3 | Judgment output 3 or alarm output   | Gray              |           |
| TM   | Timing input  | Pink              |           |
| MI   | Multifunction input: Zero set, zero set OFF, reset, change memory, teach, save, and laser control | Violet            |           |
| NP   | NPN/PNP type switching input  | Pink/ Violet      |           |
| +SD  | Transmission data   | Twisted-pair wire | Green*    |
| +SD  | Transmission data   |                   | Sky blue* |
| +RD  | Reception data  | Twisted-pair wire | Orange    |
| -RD  | Reception data  |                   | Yellow*   |
| SGND | RS422/RS485 shield  |                   |           |
| +V   | 24V DC input for power supply   | Brown             |           |
| 0V   | Power supply ground   | Blue              |           |

\*Wire color as of V1.12

## 6 I/O Circuit Diagrams

### NPN Type

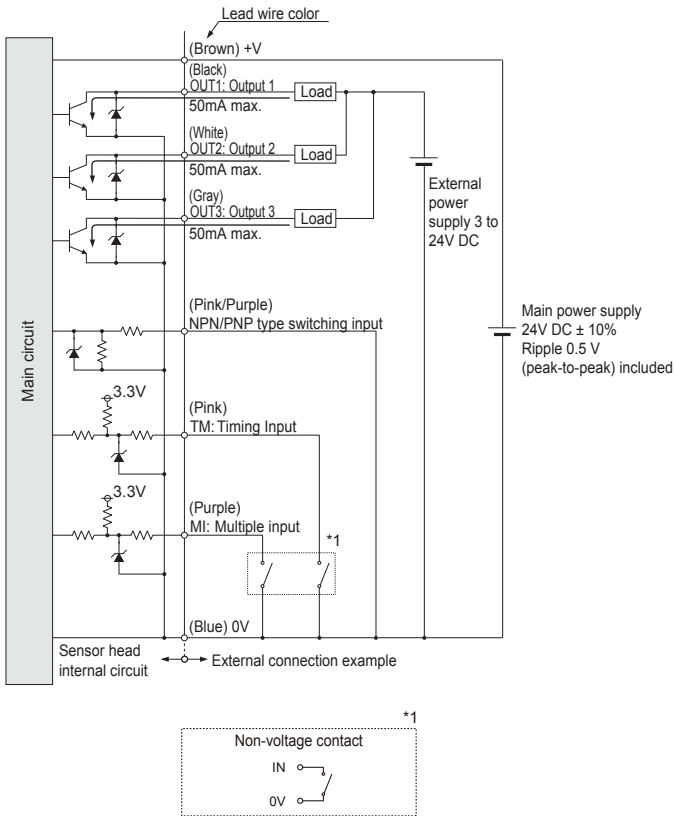

Refer to the HL-G1 Series User's Manual for RS422/RS485 wiring.

### PNP Type

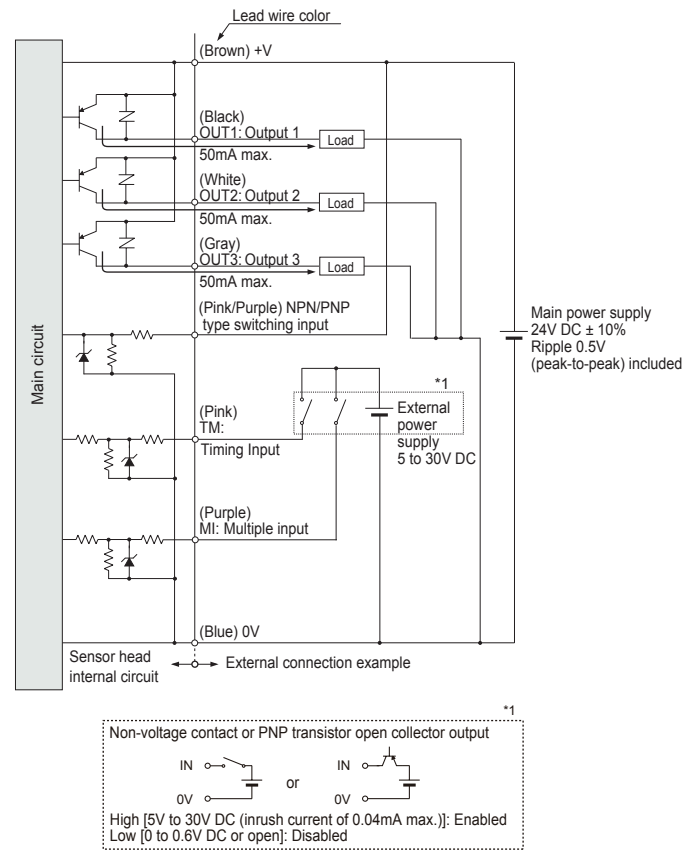

Refer to the HL-G1 Series User's Manual for RS422/RS485 wiring.

## 7 Specifications

The following measurement conditions apply unless otherwise specified:

- Power voltage: 24V DC
- Ambient temperature: 20°C
- Sampling cycle: 500μs
- Average number of sampling times: 1024 times
- Measurement object: white ceramic

| Model No.  | Standard type   | HL-G103-A-C5 | HL-G105-A-C5  | HL-G108-A-C5 | HL-G112-A-C5 |
|--|---|--------------|---|--------------|--------------|
|  | Multifunction type  | HL-G103-S-J  | HL-G105-S-J   | HL-G108-S-J  | HL-G112-S-J  |
| Measurement method                               | Diffuse reflection  |              |   |              |              |
| Measurement center distance                      | 30mm  | 50mm         | 85mm  | 120mm        |              |
| Measuring range                                  | ±4mm  | ±10mm        | ±20mm   | ±60mm        |              |
| Beam source                                      | Red semiconductor laser class 2 (JIS/IEC/FDA laser notice No. 50)<br>Max output: 1mW, Emission peak wavelength: 655nm   |              |   |              |              |
| Beam dimensions <sup>1</sup>                     | 0.1×0.1mm   | 0.5×1mm      | 0.75×1.25mm   | 1.0×1.5mm    |              |
| Beam receiving element                           | CMOS image sensor   |              |   |              |              |
| Resolution                                       | 0.5μm   | 1.5μm        | 2.5μm   | 8μm          |              |
| Linearity  | ±0.1% F.S.  |              |   |              |              |
| Temperature characteristics                      | ±0.08% F.S./°C  |              |   |              |              |
| Supply voltage                                   | 24V DC ±10% including ripple 0.5V (P-P)   |              |   |              |              |
| Current consumption                              | 100mA max.  |              |   |              |              |
| Sampling cycle                                   | 200μs, 500μs, 1ms, 2ms  |              |   |              |              |
| Analog output voltage                            | Output range: 0 to 10.5V (normal), 11V (at alarm)<br>Output impedance: 100Ω   |              |   |              |              |
| Analog output current                            | Output range: 3.2 to 20.8mA (normal), 21.6mA (at alarm)<br>Load impedance: 300Ω max.  |              |   |              |              |
| OUT1<br>OUT2<br>OUT3                             | Judgment output or alarm output (switchable)<br>NPN open-collector transistor/PNP open-collector transistor (switchable)  |              |   |              |              |
|  | <b>Settings for NPN</b>   |              | <b>Settings for PNP</b>   |              |              |
|  | <ul style="list-style-type: none"> <li>• Maximum sink current: 50mA</li> <li>• Applied voltage: 3 to 24V DC (between output and 0V)</li> <li>• Residual voltage: 2V max. (at sink current of 50mA)</li> </ul>                                   |              | <ul style="list-style-type: none"> <li>• Maximum source current: 50mA</li> <li>• Residual voltage: 2.8V max. (at source current of 50mA)</li> </ul> |              |              |
| Output operation                                 | Open when the output is ON.   |              |   |              |              |
| Short-circuit protection                         | Incorporated (Auto-reset)   |              |   |              |              |
| NPN/PNP type switching input                     | At 0V: NPN open-collector output<br>At supply voltage of 24V DC: PNP open-collector output  |              |   |              |              |
| Timing input                                     | NPN type operation: ON when connecting or connected to 0V (depending on settings)<br>PNP type operation: ON when connecting or connected to positive terminal of external power supply (depending on settings)                                  |              |   |              |              |
| Multifunction input                              | Zero set, Reset, Memory change, Teaching, Save, or Laser control depending on input time.<br>NPN type operation: Depending on time to connect 0V<br>PNP type operation: Depending on time to connect positive terminal of external power supply |              |   |              |              |
| Communications interface<br>(multifunction type) | RS422 or RS485<br>Baud rate: 9,600/19,200/38,400/115,200/230,400/460,800/921,600bps<br>Data length: 8 bits; stop bit length: 1 bit; parity check: none; BCC: yes; end code: CR  |              |   |              |              |
| Laser radiation indicator                        | Green LED: ON when laser radiation is being emitted   |              |   |              |              |
| Alarm indicator                                  | Orange LED: ON when measurement is disabled due to insufficient amount of light   |              |   |              |              |
| Output indicator                                 | Yellow LED (No. of indicators: 3): ON during output   |              |   |              |              |
| Digital display                                  | Red LED for sign and 5-digit display  |              |   |              |              |
| Degree of protection                             | IP67 (except connector)   |              |   |              |              |
| Pollution degree                                 | 2   |              |   |              |              |
| Insulation resistance                            | 20MΩ min. at 250V DC megger (between charged parts and casing)  |              |   |              |              |
| Dielectric withstand                             | Endurance: 10 to 55Hz (at 1-minute cycle), 1.5mm double-amplitude   |              |   |              |              |
| Vibration resistance                             | 1000V AC for 1 min. (between charged parts and casing)  |              |   |              |              |
| Shock resistance                                 | 500m/s <sup>2</sup> three times each in X, Y, and Z directions  |              |   |              |              |
| Ambient illumination <sup>2</sup>                | 3,000lx max. (illumination level of light receiving surface under incandescent light)   |              |   |              |              |
| Ambient temperature                              | -10°C to 45°C (No dew condensation or icing allowed);<br>At storage: -20°C to 60°C  |              |   |              |              |
| Ambient humidity                                 | 35% to 85%RH, At storage: 35% to 85%RH  |              |   |              |              |
| Altitude   | 2000m or less above sea level   |              |   |              |              |
| Material   | Casing: PBT, front cover: acrylic, cable: PVC   |              |   |              |              |
| Cable length                                     | Standard type: 5m; multifunction type: 0.5m   |              |   |              |              |
| Cable extension                                  | Multifunction type: extendable to 20m with an optional extension cable (sold separately)  |              |   |              |              |
| Weight (standard type)                           | Approx. 70g (without cable), approx. 320g (including cable), and approx. 380g (with packing)  |              |   |              |              |
| Weight (multifunction type)                      | Approx. 70g (without cable), approx. 110g (including cable), and approx. 160g (with packing)  |              |   |              |              |
| Accessory  | Laser warning label: 1 set  |              |   |              |              |
| Applicable standards                             | Conforming to EMC Directive   |              |   |              |              |

1. Inhomogeneous surfaces may reflect the laser beam such that the receiver perceives an erroneous shift in light intensity. For more details on beam dimensions, please refer to the HL-G1 User's Manual.

2. Variance is ±0.1% F.S. or less depending on the ambient illuminance.

Panasonic Electric Works SUNX Co., Ltd.

URL : <http://panasonic-electric-works.net/sunx>

Overseas Sales Division (Head Office)

2431-1 Ushiyama-cho, Kasugai-shi, Aichi, 486-0901, Japan

Phone: +81-568-33-7861 FAX: +81-568-33-8591

Europe Headquarter: Panasonic Electric Works Europe AG

Rudolf-Diesel-Ring 2, D-83607 Holzkirchen, Germany

Phone: +49-8024-648-0