

SD3-A1

Related Information

■ General terms and conditions..... F-7

■ General precautions P.1501

- FIBER SENSORS
- LASER SENSORS
- PHOTOELECTRIC SENSORS
- MICRO PHOTOELECTRIC SENSORS
- AREA SENSORS
- LIGHT CURTAINS / SAFETY COMPONENTS
- PRESSURE / FLOW SENSORS
- INDUCTIVE PROXIMITY SENSORS
- PARTICULAR USE SENSORS
- SENSOR OPTIONS
- SIMPLE WIRE-SAVING UNITS
- WIRE-SAVING SYSTEMS
- MEASUREMENT SENSORS
- STATIC ELECTRICITY PREVENTION DEVICES
- LASER MARKERS
- PLC
- HUMAN MACHINE INTERFACES
- ENERGY CONSUMPTION VISUALIZATION COMPONENTS
- FA COMPONENTS
- MACHINE VISION SYSTEMS
- UV CURING SYSTEMS



Category 3 PLd SIL2

panasonic.net/id/pidsx/global



This product is classified as a Class 1 Laser Product in IEC / JIS standards and in FDA regulations (21 CFR 1040.10 and 1040.11). Do not look at the laser beam through optical system such as a lens.

Monitor dangerous areas for unauthorized entry using flexible detection zones!

OPERATING PRINCIPLE

The safety laser scanner is used as an interlock that checks the reflection of the emitted laser and permits machine operation only when a person or an object is not present. Because it performs monitoring using invisible light, it is effective in wide areas that could not be enclosed by a safety fence or locations that become less efficient for work when they are concealed by a door or cover.

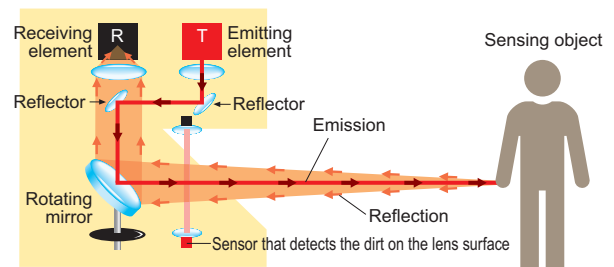
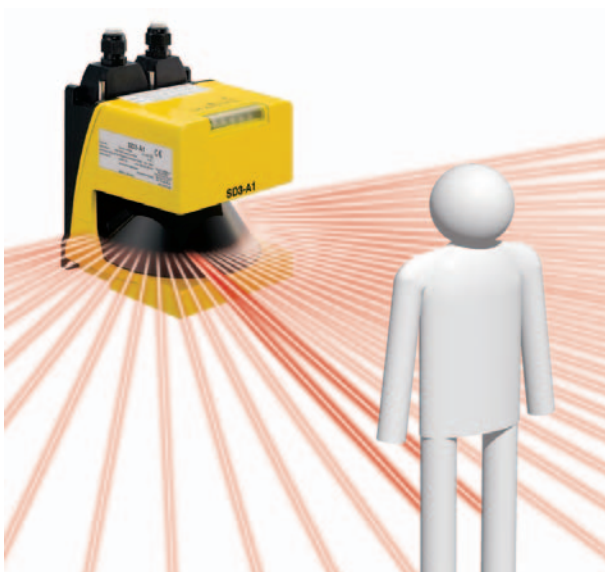

A pulsed laser beam is discharged from the emitting element (T) to the reflectors and onto a rotating mirror. The rotating mirror scans the laser as it rotates. The diffuse reflection from the sensing object is then returned to the receiving element (R) by means of the rotating mirror. The location of the sensing object is measured based on the travel time of the laser and the angular information of the rotating mirror. The monitoring area of max. 190° is divided into 528 segments (each 0.36°) by the rotating mirror.

- Selection Guide
- Light Curtains
- Safety Components
- Optical Touch Switch
- Control Units
- Definition of Sensing Heights

SG-B1/SG-A1

SG-B2

SG-C1

SG-D1

SG-E1

SD3-A1

ST4

APPLICATIONS

Detecting entry into dangerous areas at processing machines
Warning and machine halt zones are implemented to detect workers in dangerous areas.

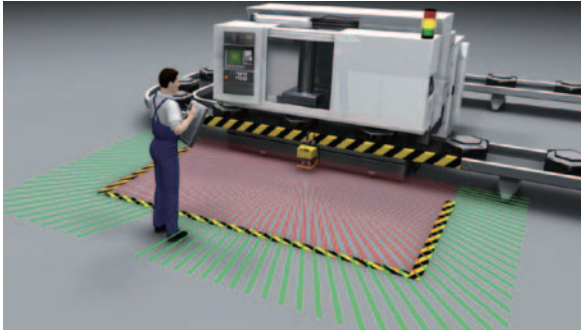

Confirming safety around automatic guided vehicles
The scanner is used to slow down the speed of the vehicle upon detection at the warning zone and stop the vehicle upon entering the detection zone.

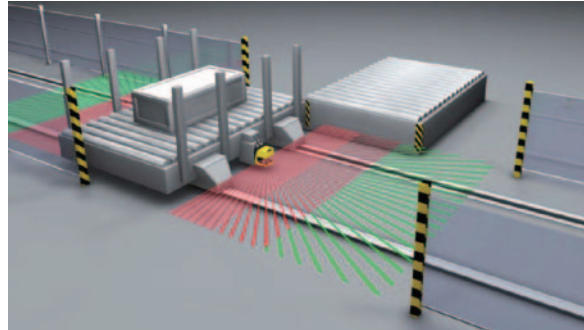

Detecting presence in a defined field
Install two safety laser scanners to build a detection zone that surrounds the monitoring object. Deactivation of detection is also possible by the flexible zone configuration.

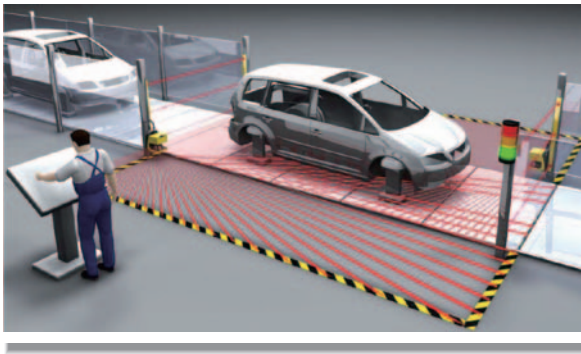

Detecting entry into dangerous areas of circular cycle tables
One safety laser scanner can safeguard the front opening, where in the past two sets of light curtains were needed.

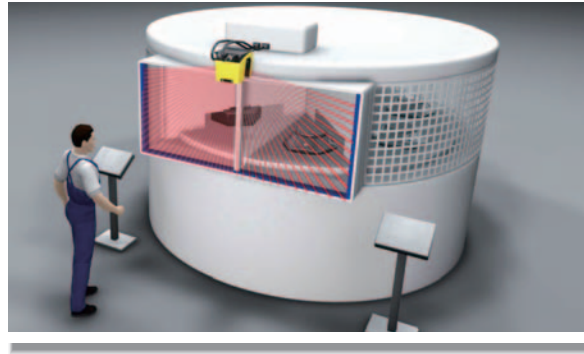

Freely configurable zones

Two zones can be widely monitored with the **SD3-A1**, the warning zone (within a radius 15 m **49.213 ft**) and the detection zone (protection zone) (within a radius 4 m **13.123 ft**). The contours of these zones are fully configurable for a perfect fit in every application. Up to eight zone patterns can be set and switched over at any given time, even during operation.

Flexible zone configuration by PC

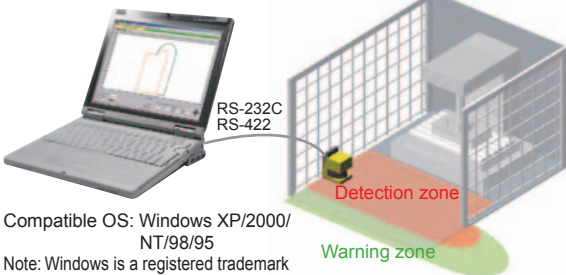

Compatible OS: Windows XP/2000/NT/98/95
Note: Windows is a registered trademark or trademark of Microsoft Corp. in the U.S. and/or other countries.

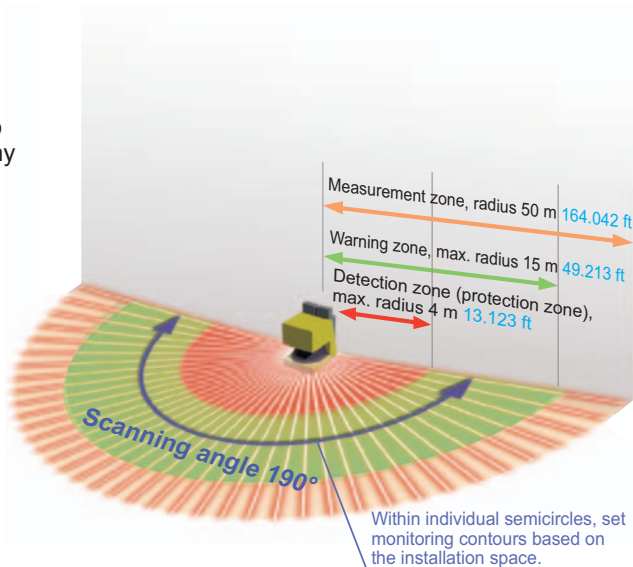

Detection zone: Instantly stops the machine upon intrusion (control output)
Warning zone: Releases warning upon intrusion (warning output)

Up to 8 freely switchable zone patterns

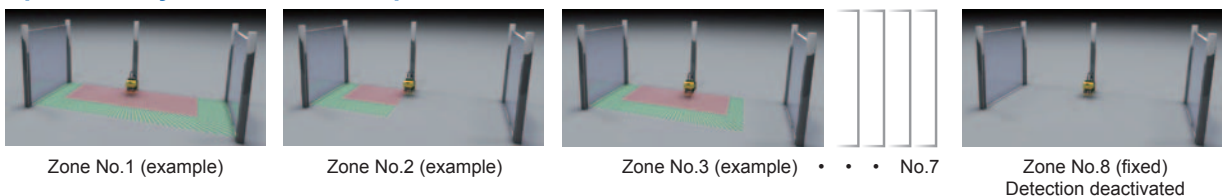

- FIBER SENSORS
- LASER SENSORS
- PHOTOELECTRIC SENSORS
- MICRO PHOTOELECTRIC SENSORS
- AREA SENSORS
- LIGHT CURTAINS / SAFETY COMPONENTS
- PRESSURE / FLOW SENSORS
- INDUCTIVE PROXIMITY SENSORS
- PARTICULAR USE SENSORS
- SENSOR OPTIONS
- SIMPLE WIRE-SAVING UNITS
- WIRE-SAVING SYSTEMS
- MEASUREMENT SENSORS
- STATIC ELECTRICITY PREVENTION DEVICES
- LASER MARKERS
- PLC
- HUMAN MACHINE INTERFACES
- ENERGY CONSUMPTION VISUALIZATION COMPONENTS
- FA COMPONENTS
- MACHINE VISION SYSTEMS
- UV CURING SYSTEMS

- Selection Guide
- Light Curtains
- Safety Components
- Optical Touch Switch
- Control Units
- Definition of Sensing Heights

- SG-B1/SG-A1
- SG-B2
- SG-C1
- SG-D1
- SG-E1
- SD3-A1
- ST4

- FIBER SENSORS
- LASER SENSORS
- PHOTOELECTRIC SENSORS
- MICRO PHOTOELECTRIC SENSORS
- AREA SENSORS
- LIGHT CURTAINS / SAFETY COMPONENTS
- PRESSURE / FLOW SENSORS
- INDUCTIVE PROXIMITY SENSORS
- PARTICULAR USE SENSORS
- SENSOR OPTIONS
- SIMPLE WIRE-SAVING UNITS
- WIRE-SAVING SYSTEMS
- MEASUREMENT SENSORS
- STATIC ELECTRICITY PREVENTION DEVICES
- LASER MARKERS
- PLC
- HUMAN MACHINE INTERFACES
- ENERGY CONSUMPTION VISUALIZATION COMPONENTS
- FA COMPONENTS
- MACHINE VISION SYSTEMS
- UV CURING SYSTEMS

Compact size

Compact size of W140 × H195 × D135 mm
W5.512 × H7.677 × D5.315 in

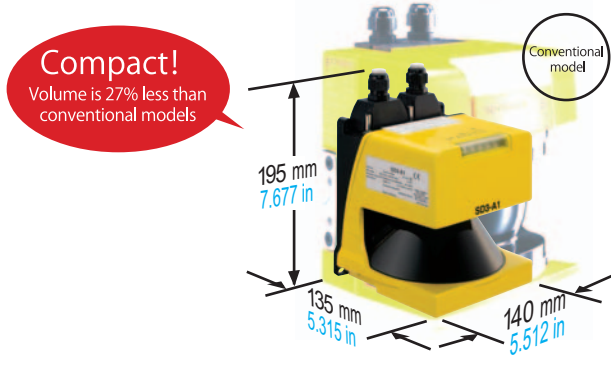

Monitors beam misalignment after installation of safety laser scanner

By activating the reference boundary function which enables constant detection of stationary objects, the safety laser scanner memorizes the position of stationary objects, and monitors for beam misalignment after installation.

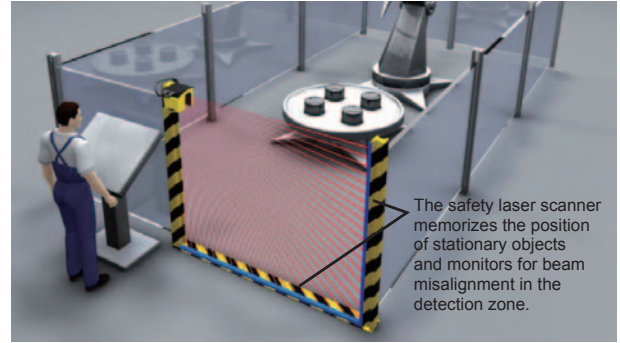

Prevents malfunctions caused by insects and dust

The safety laser scanner reduces malfunctions due to small insects and dust through its unique algorithm, "dust suppression function".

Adjustment of response times enables interference prevention

The response time is adjustable within the range from 80 to 640 ms. When setting up multiple safety laser scanners in close vicinity, mutual interference can be prevented by adjusting the response time.

Memorized configurations make post-maintenance recovery easy (Optional)

Configurations can be saved in the optional configuration plug which has a built-in memory. Even after maintenance or interchanging of safety laser scanners, the configurations from the memory in the plug can be easily loaded and recovered without the need to configure through a PC.



- Selection Guide
- Light Curtains
- Safety Components
- Optical Touch Switch
- Control Units
- Definition of Sensing Heights

- SG-B1/SG-A1
- SG-B2
- SG-C1
- SG-D1
- SG-E1
- SD3-A1**
- ST4

ORDER GUIDE

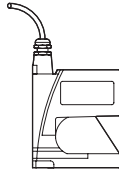
Designation	Appearance	Model No.	Control outputs (OSSD 1, OSSD 2)
Safety laser scanner		SD3-A1	PNP open-collector transistor 2 outputs

Spare parts (Accessories for safety laser scanner)

Designation	Model No.	Description
Straight connector for 15-pin connector side	SD3-PS	Exclusive 15-pin connector. Straight type. For soldering. Net weight: 35 g approx.
Straight connector for 9-pin connector side	SD3-RS232	Exclusive 9-pin connector. Straight type. For soldering. Net weight: 30 g approx.
Scanner window	SD3-WINDOW	Replacement lens for safety laser scanner body. Net weight: 45 g approx.

Straight connector for 15-pin connector side

- **SD3-PS**



Two M5 (length 20 mm 0.787 in) hexagon-socket-head bolts, two M5 (length 16 mm 0.630 in) hexagon-socket-head bolts, and two cylindrical nuts are attached.

Straight connector for 9-pin connector side

- **SD3-RS232**

Two cylindrical nuts are attached.



Scanner window

- **SD3-WINDOW**



FIBER SENSORS

LASER SENSORS

PHOTO-ELECTRIC SENSORS

MICRO PHOTO-ELECTRIC SENSORS

AREA SENSORS

LIGHT CURTAINS / SAFETY COMPONENTS

PRESSURE / FLOW SENSORS

INDUCTIVE PROXIMITY SENSORS

PARTICULAR USE SENSORS

SENSOR OPTIONS

SIMPLE WIRE-SAVING UNITS

WIRE-SAVING SYSTEMS

MEASUREMENT SENSORS

STATIC ELECTRICITY PREVENTION DEVICES

LASER MARKERS

PLC

HUMAN MACHINE INTERFACES

ENERGY CONSUMPTION VISUALIZATION COMPONENTS

FA COMPONENTS

MACHINE VISION SYSTEMS

UV CURING SYSTEMS

Selection Guide

Light Curtains

Safety Components

Optical Touch Switch

Control Units

Definition of Sensing Heights

SG-B1/SG-A1

SG-B2

SG-C1

SG-D1

SG-E1

SD3-A1

ST4

OPTIONS

Designation	Model No.	Description	
Mounting bracket	MS-SD3-1	Used to mount the safety laser scanner in rear direction. Net weight: 530 g approx.	
15-pin connector side	Rear elbow connector SD3-PS-L	Exclusive 15-pin connector. Rear elbow type. For soldering. Net weight: 35 g approx.	
	Configuration plug SD3-CP	15-pin connector with built-in memory that saves setting information. For soldering. Net weight: 35 g approx.	
	Configuration plug attached cable	SD3-CP-C5	Cable length: 5 m 16.404 ft Net weight: 690 g approx. (1 cable)
		SD3-CP-C10	Cable length: 10 m 32.808 ft Net weight: 1.3 kg approx. (1 cable)
		SD3-CP-C25	Cable length: 25 m 82.021 ft Net weight: 3.3 kg approx. (1 cable)
		SD3-CP-C50	Cable length: 50 m 164.042 ft Net weight: 6.3 kg approx. (1 cable)
		SD3-CP-C10-L	Cable length: 10 m 32.808 ft Elbow type Net weight: 1.3 kg approx. (1 cable)
9-pin connector side	Rear elbow connector SD3-RS232-L	Exclusive 9-pin connector used when PC is not connected. Rear elbow type. Cable soldering is possible. Net weight: 30 g approx.	
	PC connection cable	SD3-RS232-C3	Cable length: 3 m 9.843 ft Net weight: 160 g approx. (1 cable)
		SD3-RS232-C5	Cable length: 5 m 16.404 ft Net weight: 230 g approx. (1 cable)
		SD3-RS232-C10	Cable length: 10 m 32.808 ft Net weight: 400 g approx. (1 cable)
Operation checking tool	SD3-DEMO-24V	Configuration and test device for safety laser scanner. Supply voltage: 24 V DC, Net weight: 270 g approx.	
Cleaning set	SD3-CLEAN1	Used to clean scanner window (lens surface). Cleaning fluid 150 ml, cleaning cloth 25 sheets.	
	SD3-CLEAN2	Used to clean scanner window (lens surface). Cleaning fluid 1 ℓ, cleaning cloth 100 sheets.	

Mounting bracket

- MS-SD3-1



Two M8 (length 45 mm **1.772 in**) hexagon-socket-head bolts, two plain washers for M8, two M5 (length 20 mm **0.787 in**) hexagon-socket-head bolts, two M5 (length 16 mm **0.630 in**) hexagon-socket-head bolts, and four plain washers for M5 are attached.

Rear elbow connector

- SD3-PS-L



Two cylindrical nuts are attached.

Configuration plug

- SD3-CP



Two cylindrical nuts are attached.

Configuration plug attached cable

- SD3-CP-C□
- SD3-CP-C10-L



Rear elbow connector

- SD3-RS232-L



Two cylindrical nuts are attached.

PC connection cable

- SD3-RS232-C□



Operation checking tool

- SD3-DEMO-24V



One exclusive connection cable is attached.

Cleaning set

- SD3-CLEAN1
- SD3-CLEAN2



FIBER SENSORS
LASER SENSORS
PHOTO-ELECTRIC SENSORS
MICRO PHOTO-ELECTRIC SENSORS
AREA SENSORS
LIGHT CURTAINS SAFETY COMPONENTS
PRESSURE / FLOW SENSORS
INDUCTIVE PROXIMITY SENSORS
PARTICULAR USE SENSORS
SENSOR OPTIONS
SIMPLE WIRE-SAVING UNITS
WIRE-SAVING SYSTEMS
MEASUREMENT SENSORS
STATIC ELECTRICITY PREVENTION DEVICES
LASER MARKERS
PLC
HUMAN MACHINE INTERFACES
ENERGY CONSUMPTION VISUALIZATION COMPONENTS
FA COMPONENTS
MACHINE VISION SYSTEMS
UV CURRING SYSTEMS

Selection Guide
Light Curtains
Safety Components
Optical Touch Switch
Control Units
Definition of Sensing Heights
SG-B1/SG-A1
SG-B2
SG-C1
SG-D1
SG-E1
SD3-A1
ST4

SPECIFICATIONS

Item	Type	Safety laser scanner				
	Model No.	SD3-A1				
Applicable standards	International standards	IEC 61496-1/3 (Type 3), ISO 13849-1 (Category 3, PLd), IEC 61508-1 to 7 (SIL2), IEC 62061 (SIL2)				
	Japan	JIS B 9704-1/3 (Type 3), JIS B 9705-1 (Category 3), JIS C 0508 (SIL2)				
	Europe (EU)	EN 61496-1 (Type 3), ISO 13849-1 (Category 3, PLd), EN 61508-1 to 7 (SIL2)				
Detection zone	Min. sensing object setting	ø150 mm ø5.906 in	ø70 mm ø2.756 in	ø50 mm ø1.969 in	ø40 mm ø1.575 in	ø30mm ø1.181 in
	Sensing range (radius)	0 to 4.0 m 0 to 13.123 ft	0 to 4.0 m 0 to 13.123 ft	0 to 2.8 m 0 to 9.186 ft	0 to 2.2 m 0 to 7.218 ft	0 to 1.6m 0 to 5.249 ft
	Measurement error margin extended range	When dust suppression function is not selected: 83mm 3.268 in When dust suppression function is selected: 83 mm 3.268 in for less than 3.5 mm 0.138 in , and 100 mm 3.937 in for 3.5 mm 0.138 in or more (automatically calculated using the included software)				
	Sensing object reflectance	Minimum 1.8 %				
Warning zone	Min. sensing object setting	ø150 mm ø5.906 in (fixed)				
	Sensing range (radius)	0 to 15 m 0 to 49.213 ft				
	Sensing object reflectance	Minimum 20 %				
Measurement zone	Max. measurement range (radius)	50 m 164.042 ft (fixed)				
Scanning angle		190° / 180° (by setting)				
Number of zone setting		Max. 7 + 1 (without detection zone) [Zone pairs in combination of detection zone and warning zone can be switched over by external input]				
Min. zone setting range		200 mm 7.874 in				
Supply voltage (U _B)		24 V DC ⁺²⁰ / ₋₃₀ % (IEC 60742)				
Current consumption		300 mA approx. (excluding external connection load)				
Fuse (power supply)		1.25 A semi-time-lag fuse				
Control outputs (OSSD 1, OSSD 2)		PNP open-collector transistor 2 outputs • Rated operating voltage: supply voltage (U _B) – 3.2 V • Max. source current: 250 mA • Residual voltage: 3.2 V or less				
Operation mode		When no object enters into the detection zone: ON, When an object enters: OFF				
Response time		Min. 80 ms (2 scans) to max. 640 ms (16 scans) switching method				
Protection circuit		Incorporated				
Warning output 1 (Alarm 1)		PNP open-collector transistor • Rated operating voltage: supply voltage (U _B) – 4 V • Max. source current: 100 mA • Residual voltage: 4 V or less				
Operation mode		Switching method of operation mode (set by below) • Not used • Main unit at normal operation: ON, Abnormal operation: OFF • When no object enters into the warning zone: ON, When an object enters: OFF • Main unit at normal operation: ON, Abnormal operation: OFF and When no object enters into the warning zone: ON, When an object enters: OFF				
Response time		Min. 80 ms (2 scans) to max. 640 ms (16 scans) switching method				
Warning output 2 (Alarm 2)		PNP open-collector transistor • Rated operating voltage: supply voltage (U _B) – 4 V • Max. source current: 100 mA • Residual voltage: 4 V or less				
Operation mode		Main unit at normal operation: ON, Abnormal operation: OFF				
Laser protection class		Class 1 [IEC 60825, FDA (Note 2)]				
Peak emission wavelength		905 nm 0.036 mil				
Environmental resistance	Degree of protection	IP65				
	Ambient temperature	0 to +50 °C +32 to +122 °F , Storage: -20 to +60 °C -4 to +140 °F				
	Ambient humidity	Operation and storage: Max. 95 % RH (No dew condensation)				
	Vibration resistance / Shock resistance	10 to 150 Hz frequency, 5 G max. (50 m/s ² approx.) in X, Y and Z directions for twenty times each				
Maximum cable length		15-pin plug: Max. 50 m 164.042 ft , 9-pin plug: Max. 10 m 32.808 ft (when using RS-232C) / Max. 50 m 164.042 ft (when using RS-422) (by using optional connection cable) (Note 1)				
Material		Main body: Die-cast aluminum, Scanner window: Thermoplastic resin				
Accessories		SD3-PS (exclusive 15-pin connector): 1 pc., SD3-RS232 (exclusive 9-pin connector): 1 pc., Mounting screws [M5 (length 20 mm 0.787 in) hexagon-socket-head bolt: 2 pcs., M5 (length 16 mm 0.630 in) hexagon-socket-head bolt: 2 pcs., attached to SD3-PS]: 1 set, Simplified instruction manual: 1 copy, Installation CD-ROM (includes detailed instruction manual data): 1 CD				
Weight		Net weight: 2.1 kg approx., Gross weight: 2.9 kg approx.				

Notes: 1) Be careful that a voltage drop may occur depending on the cable length or cable's conductor cross-section area.
2) In accordance Laser Warning 50 (2007.6.24), based on FDA regulations (21 CFR 1040.10, 1040.11).

FIBER
SENSORSLASER
SENSORSPHOTO-
ELECTRIC
SENSORSMICRO
PHOTO-
ELECTRIC
SENSORSAREA
SENSORSLIGHT
CURTAINS/
SAFETY
COMPONENTSPRESSURE /
FLOW
SENSORSINDUCTIVE
PROXIMITY
SENSORSPARTICULAR
USE
SENSORSSENSOR
OPTIONSSIMPLE
WIRE-SAVING
UNITSWIRE-SAVING
SYSTEMSMEASURE-
MENT
SENSORSSTATIC
ELECTRICITY
PREVENTION
DEVICESLASER
MARKERS

PLC

HUMAN
MACHINE
INTERFACESENERGY
CONSUMPTION
VISUALIZATION
COMPONENTSFA
COMPONENTSMACHINE
VISION
SYSTEMSUV
CURING
SYSTEMSSelection
GuideLight
CurtainsSafety
ComponentsOptical Touch
SwitchControl
UnitsDefinition of
Sensing
Heights**SG-B1/SG-A1****SG-B2****SG-C1****SG-D1****SG-E1****SD3-A1****ST4**

- FIBER SENSORS
- LASER SENSORS
- PHOTO-ELECTRIC SENSORS
- MICRO PHOTO-ELECTRIC SENSORS
- AREA SENSORS
- LIGHT CURTAINS SAFETY COMPONENTS
- PRESSURE / FLOW SENSORS
- INDUCTIVE PROXIMITY SENSORS
- PARTICULAR USE SENSORS
- SENSOR OPTIONS
- SIMPLE WIRE-SAVING UNITS
- WIRE-SAVING SYSTEMS
- MEASUREMENT SENSORS
- STATIC ELECTRICITY PREVENTION DEVICES
- LASER MARKERS
- PLC
- HUMAN MACHINE INTERFACES
- ENERGY CONSUMPTION VISUALIZATION COMPONENTS
- FA COMPONENTS
- MACHINE VISION SYSTEMS
- UV CURING SYSTEMS
- Selection Guide
- Light Curtains
- Safety Components
- Optical Touch Switch
- Control Units
- Definition of Sensing Heights
- SG-B1/SG-A1
- SG-B2
- SG-C1
- SG-D1
- SG-E1
- SD3-A1**
- ST4

I/O CIRCUIT AND WIRING DIAGRAMS

Connection wiring example with control unit SF-C13

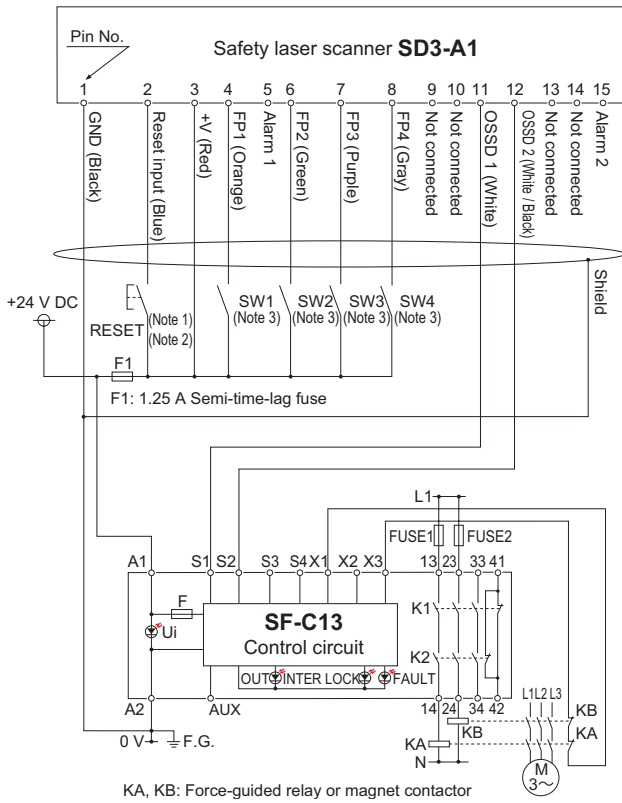

- Notes: 1) The above diagram is when using manual reset. If automatic reset is used, a reset (RESET) button is not needed. Settings by software are needed separately.
 2) Use a momentary-type switch as the reset (RESET) button.
 3) For zone-control inputs (SW1 to 4), use PLC etc. (input time should be 40 ms or less).

Zone No.	Control inputs			
	FP1	FP2	FP3	FP4
1	1	0	0	0
2	0	1	0	0
3	0	0	1	0
4	0	0	0	1
5	1	1	1	0
6	1	1	0	1
7	1	0	1	1
8	0	1	1	1

PRECAUTIONS FOR PROPER USE

Refer to p.1501 for general precautions and p.1499~ for information about laser beam.

Wiring

- Make sure that the power supply is off while wiring.
- Do not run the wires together with high-voltage lines or power lines or put them in the same raceway. This can cause malfunction due to induction.
- Faulty wiring can damage internal circuitry so check the wiring before turning the power on.

Others

- Avoid using the device in places that are humid and dusty, places where water and medicine are stored, or where there are corrosive gases in the air.
- Take care that the sensor does not come in direct contact with water, oil, grease or organic solvents, such as, thinner, etc.

DIMENSIONS (Unit: mm in)

The CAD data in the dimensions can be downloaded from our website.

SD3-A1

Safety laser scanner

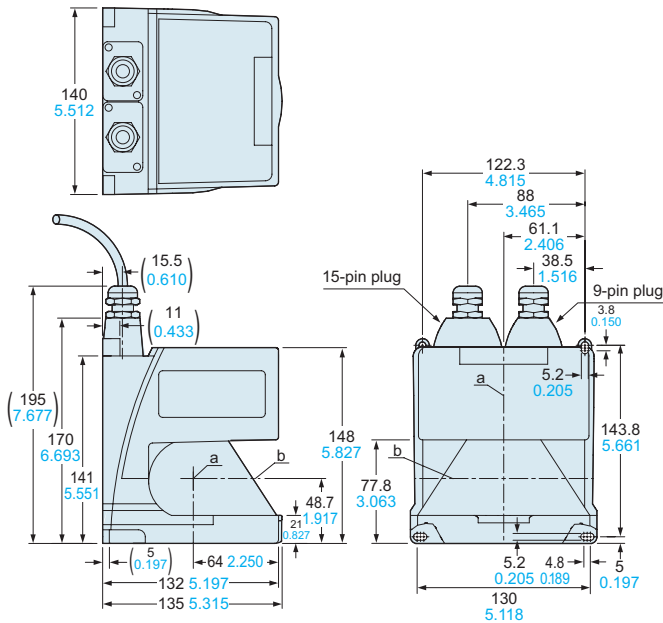

a: Rotating mirror axis
b: Scan level (beam axis)

MS-SD3-1

Mounting bracket (Optional)

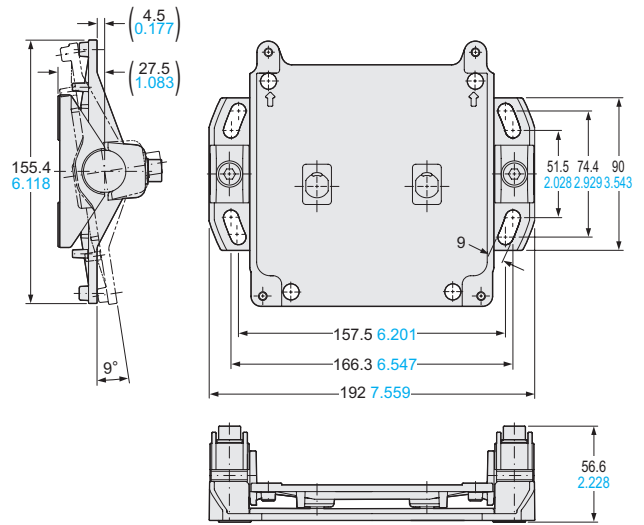

Material: Aluminum
Net weight: 530 g approx.

Two M8 (length 45 mm 1.772 in) hexagon-socket-head bolts, two plain washers for M8, two M5 (length 20 mm 0.787 in) hexagon-socket-head bolts, two M5 (length 16 mm 0.630 in) hexagon-socket-head bolts, and four plain washers for M5 are attached.

FIBER SENSORS

LASER SENSORS

PHOTO-ELECTRIC SENSORS

MICRO PHOTO-ELECTRIC SENSORS

AREA SENSORS

LIGHT CURTAINS/SAFETY COMPONENTS

PRESSURE / FLOW SENSORS

INDUCTIVE PROXIMITY SENSORS

PARTICULAR USE SENSORS

SENSOR OPTIONS

SIMPLE WIRE-SAVING UNITS

WIRE-SAVING SYSTEMS

MEASUREMENT SENSORS

STATIC ELECTRICITY PREVENTION DEVICES

LASER MARKERS

PLC

HUMAN MACHINE INTERFACES

ENERGY CONSUMPTION VISUALIZATION COMPONENTS

FA COMPONENTS

MACHINE VISION SYSTEMS

UV CURING SYSTEMS

Selection Guide

Light Curtains

Safety Components

Optical Touch Switch

Control Units

Definition of Sensing Heights

SG-B1/SG-A1

SG-B2

SG-C1

SG-D1

SG-E1

SD3-A1

ST4