

Panasonic[®]

SAFETY BEAM SENSOR

ST4

Instruction Manual

BEFORE BEGINNING

The printed English and Japanese versions of this instruction manual are the original versions.

The English, French, German, Italian and Spanish versions published in the Internet are copies of the original documentation and were produced by Panasonic Electric Works Europe AG.

Liability and Copyright for the Hardware

This manual and everything described in it are copyrighted. You may not copy this manual, in whole or part, without written consent of Panasonic Electric Works Europe AG (PEWEU).

PEWEU pursues a policy of continuous improvement of the design and performance of its products. Therefore we reserve the right to change the manual/product without notice. In no event will PEWEU be liable for direct, special, incidental, or consequential damage resulting from any defect in the product or its documentation, even if advised of the possibility of such damages.

We invite your comments on this manual. Please e-mail us at:

tech-doc@eu.pewg.panasonic.com.

Please direct support matters and technical questions to your local Panasonic representative.

LIMITED WARRANTY

If physical defects caused by distribution are found, PEWEU will replace/repair the product free of charge. Exceptions include:

- When physical defects are due to different usage/treatment of the product other than described in the manual.
- When physical defects are due to defective equipment other than the distributed product.
- When physical defects are due to modifications/repairs by someone other than PEWEU.
- When physical defects are due to natural disasters.

Important Symbols

One or more of the following symbols may be used in this documentation:



DANGER!

The warning triangle indicates especially important safety instructions. If they are not adhered to, the results could be fatal or critical injury.



◆ **CAUTION**

Indicates that you should proceed with caution. Failure to do so may result in injury or significant damage to instruments or their contents, e.g. data.



◆ **NOTE**

Contains important additional information.



◆ **EXAMPLE**

Contains an illustrative example of the previous text section.



◆ **Procedure**

Indicates that a step-by-step procedure follows.



◆ **REFERENCE**

Indicates where you can find additional information on the subject at hand.



◆ KEY POINTS

Summarizes key points in a concise manner.



◆ SHORTCUTS

Provides helpful keyboard shortcuts.



◆ EXPLANATION

Provides a brief explanation of a function, e.g. why or when you should use it.

➡ next page

Indicates that the text will be continued on the next page.

Table of Contents

1. Introduction	1
1.1 Target Group	2
1.2 Safety Instructions	3
1.3 Applicable Standards/Regulations.....	6
2. Before Using this Device	7
2.1 Features.....	8
2.2 Part Description	9
2.2.1 Elements of the Controller ST4-C11	10
2.2.2 Elements of the Multifunctional Controller ST4-C12EX	11
2.2.3 Elements of the Sensor ST4-A.....	14
2.3 Protection Area	15
2.3.1 Sensing Range.....	15
2.3.2 Safety Distance	16
2.3.2.1 Calculation Example for Europe	17
2.3.2.2 Calculation Example for the US	18
2.3.3 Influence of Reflective Surfaces.....	20
2.3.4 Placement of Emitter and Receiver	21
2.3.5 Connecting Multiple Sensors Heads.....	23
2.3.6 Address Allocations of the Sensor ST4-A□.....	25
2.4 Mounting and Removing	29
2.4.1 Mounting and Removing the Controller	29
2.4.2 Mounting the Sensor ST4-A□.....	30
2.4.3 Connecting Controller and Sensor ST4-A□	31
2.4.4 Series Connection of the Sensor ST4-A□.....	32

2.5	Wiring	36
2.5.1	Power Supply Unit.....	36
2.5.2	I/O Circuit Diagrams	37
2.5.2.1	Circuit of Controller ST4-C11	37
2.5.2.2	Circuit of Multifunctional Controller ST4-C12EX	38
2.5.2.3	Manual and automatic reset.....	39
2.5.2.4	Emission Halt Input Terminals	40
2.5.3	Connecting to the Terminal Block	41
2.5.4	Terminal Arrangement Diagram.....	41
2.6	Adjustment and Operation.....	44
2.6.1	Beam-Axis Alignment.....	44
2.6.2	Operation Test.....	46
2.6.3	Operation.....	47
3.	Functions	49
3.1	Self-Diagnosis Function	50
3.2	Reset Operation	51
3.2.1	Manual Reset	51
3.2.2	Auto Reset.....	52
3.3	Emission Halt Function.....	53
3.4	Interference Prevention Function	54
3.4.1	Interference Prevention With One Controller	54
3.4.2	Interference Prevention Function When Using Two or More Controllers	54
3.5	Auxiliary Output	56
3.5.1	Auxiliary Output Operation of Controller ST4-C11	56
3.5.2	Auxiliary Output Operation of Controller ST4-C12EX	56
3.5.3	Emission Amount Adjustment Function	57
3.6	Muting Function (Only for ST4-C12EX).....	59
3.6.1	What Is a Muting Sensor	60
3.6.2	Installation of the Muting Sensor.....	60

3.7	Override Function (Only ST4-C12EX)	63
3.8	Muting Pattern Selection Function (Only ST4-C12EX).....	67
3.8.1	Control Condition of Muting Pattern No. 1	68
3.8.2	Control Condition of Muting Pattern No. 2	69
3.8.3	Control Condition of Muting Pattern No. 3	70
3.9	Sensor Diagnosis Function (Only ST4-C12EX).....	71
3.10	Muting Lamp Diagnosis Function (Only ST4-C12EX)	74
4.	Maintenance.....	75
4.1	Daily Inspection	76
4.2	Periodic Inspection Checklist (Every Six Months)	77
4.3	Inspection After Maintenance	78
5.	Troubleshooting	79
5.1	Troubleshooting of Controller ST4-C11	80
5.2	Troubleshooting of Controller ST4-C12EX	83
5.3	Troubleshooting of the Sensor ST4-A□	86
6.	Specifications	87
6.1	Specifications, Controller ST4-C11.....	88
6.2	Specifications, Controller ST4-C12EX.....	90
6.3	Specifications, Sensor ST4-A□.....	92
6.4	Options	93
6.4.1	Extension Cable	93
6.4.2	Branch Cable.....	93
6.4.3	Foot Angled Mounting Bracket.....	93

6.4.4	Back Angled Mounting Bracket	94
6.4.5	Foot Biangled Protective Mounting Bracket.....	94
6.4.6	Slit Masks	94
7.	Dimensions.....	95
7.1	Controller ST4-C11	96
7.2	Multifunctional Controller ST4-C12EX.....	97
7.3	Single-beam Sensor ST4-A□	98
7.4	Branch Cable ST4-CCJ05-WY	99
7.5	Foot Angled Mounting Bracket MS-CX-1	100
7.6	Back Angled Mounting Bracket MS-ST4-3.....	101
7.7	Foot Biangled Protective Mounting Bracket MS-ST4-6.....	102
8.	Glossary of Terms.....	103
9.	Index.....	105

Chapter 1

Introduction

1.1 Target Group

Thank you for purchasing the Panasonic Safety Beam Sensor ST4 series (hereafter called 'this device'). Please read this instruction manual carefully and thoroughly for the correct and optimum use of this product. Kindly keep this manual in a convenient place for quick reference.

This device is a safety beam sensor for protecting a person from dangerous parts of a machine which can cause injury or accident.

This manual has been written for the personnel who:

- have undergone suitable training and have knowledge of safety beam sensors as well as safety systems and standards.
- are responsible for this device
- design systems using this device
- install and connect this device
- manage and operate a plant using this device

Machine designer, installer, employer and operator

The machine designer, installer, employer and operator are solely responsible for ensuring that all applicable legal requirements relating to the installation and the use in any application are satisfied and all instructions for installation and maintenance contained in the instruction manual are followed.

Whether this device functions as intended and systems including this device comply with safety regulations depend on the appropriateness of the application, installation, maintenance and operation. The machine designer, installer, employer and operator are solely responsible for these items.

Engineer

The engineer must be a person who is appropriately trained, has widespread knowledge and experience, and can solve various problems which may arise in his field of work, e.g. as a machine designer or a person in charge of installation or operation, etc.

Operator

The operator should read this instruction manual thoroughly, understand its contents, and perform operations following the procedures described in this manual for the correct operation of this device.

In case this device does not perform properly, the operator should report this to the person in charge and stop machine operation immediately. The machine must not be used until correct performance of this device has been confirmed.

1.2 Safety Instructions



DANGER!

Please adhere to the following safety instructions when you install and operate this device. Failure to do so can result in fatal or critical injury during unprotected use of hazardous machinery.

- Use this device as per its specifications. Do not modify the safety beam sensor since its functions and capabilities may not be maintained and it may malfunction.
- The safety beam sensor has been developed/produced for industrial use only.
- Do not use the safety beam sensor under conditions or in environments not described in this manual. Please consult us if there is no other choice but to use this device in such an environment.
- Do not use the safety beam sensor in fields such as nuclear power control, railroad, aircraft, automobiles, combustion facilities, medical systems, aerospace development, e.g. in applications where failure could result in large-scale damage to society or people.
- When the safety beam sensor is to be used for enforcing protection of a person from any danger occurring around an operating machine, the user must satisfy the regulations established by national or regional security committees.
- No matter what kind of equipment you use the device with, follow the safety regulations in regard to appropriate usage, mounting (installation), operation and maintenance.
- Use the safety beam sensor by installing suitable protective equipment as a countermeasure for failure, damage, or malfunction of this device.
- Before using this sensor, check whether the device performs properly and has the functions and capabilities as stated in the design specifications.
- Dispose of the safety beam sensor as industrial waste.

Environment

- Do not use a mobile phone or a radio phone near this device.
- If the sensor is installed in a place where there are reflective surfaces, make sure to install this device so that reflected light from the reflective surfaces does not affect the receiver. Alternatively, take countermeasures such as painting, masking, roughening, or changing the material of the reflective surfaces, etc. Failure to do so may cause the sensor not to detect properly, which may result in death or serious injury.
- Do not install the safety beam sensor in the following environments:

- Areas exposed to intense interference light such as direct sunlight
- Areas with high humidity where condensation is likely to occur
- Areas exposed to corrosive or explosive gases
- Areas exposed to vibration or shock at levels higher than those specified
- Areas exposed to contact with water
- Areas exposed to excessive steam or dust
- Areas where the beam-receiving part of this device is directly exposed to light from a high-frequency fluorescent lamp (inverter type) or rapid-starter fluorescent lamp.

Installation

- Always keep the correctly calculated safety distance between the safety beam sensor and the dangerous parts of the machine.
- Install an extra protective structure around the machine so that the operator must pass through the sensing area of the safety beam sensor to reach the dangerous parts of the machine.
- Install the beam sensor in a manner that some part of the operator's body always remains in the sensing area until the operator has finished working with the dangerous parts of the machine.
- Do not install the beam sensor at a location where it can be affected by wall reflection.
- When installing multiple sets of the safety beam sensor, connect the sets and, if necessary, install some barriers so that mutual interference does not occur.
- Do not use any reflection type or recursive reflection type arrangement.

Equipment in which this device is installed

- When the safety beam sensor is used in the PSDI mode, an appropriate control circuit must be configured between this device and the machinery. For details, be sure to refer to the standards or regulations applicable in each region or country.
- In Japan, do not use the safety beam sensor as safety equipment for a press machine.
- Do not install the safety beam sensor with a machine whose operation cannot be stopped immediately in the middle of an operation cycle by an emergency stop.
- This sensor provides safety 2 seconds after the power has been switched ON. Make sure that the control system takes the time delay into consideration.

Wiring

- Switch off the power before wiring the safety beam sensor.

- **All electrical wiring should conform to the regional electrical regulations and laws. The wiring should be done by skilled personnel with the required electrical knowledge.**
- **Do not run the sensor cable together with high-voltage lines or power lines or put them together in the same raceway.**
- **In case you need to extend the cable of the ST4-A□, you can use the dedicated extension cable. The cable can be extended up to 50m (emitter and receiver, respectively).**
- **Do not control the device at only one control output (OSSD 1, OSSD 2).**
- **To ensure that the output is not turned ON due to an earth fault of the control output (OSSD 1, OSSD 2), ground the device on the 0V side (for PNP output) or +24V side (for NPN output).**

Maintenance

- **When you need to replace parts, always use only genuine replacement parts from the supplier. If you use substitute parts from another manufacturer, the sensor may fail to detect properly, which may result in death or serious body injury.**
- **The device must be inspected periodically by an engineer with the required knowledge.**
- **When you have adjusted or maintained the device, test the device following the procedure specified in the maintenance chapter before you switch the system back on.**
- **Clean this device with a clean cloth. Do not use thinner-based cleaners.**

Others

- **Never modify this device. If you modify the device, the sensor may fail to detect properly, which may result in death or serious injury.**
- **Do not use this device to detect objects flying over the sensing area.**
- **Do not use this device to detect transparent objects, translucent objects or objects smaller than the specified minimum sensing size.**

1.3 Applicable Standards/Regulations

This device complies with the following standards and regulations.

- EU Machinery Directive 98/37/EC, EMC Directive 2004/108/EC
- EN 61496-1 (Type 4), EN 55011, EN 50178, EN ISO 13849 (Category 4, PLe), EN 61508-1 to 7 (SIL3)
- IEC 61496-1/2 (Type 4), ISO 13849-1 (Category 4, PLe), IEC 61508-1 to 7 (SIL3), IEC 62061 (SIL3)
- JIS B 9704-1/2 (Type 4), JIS B 9705-1 (ISO 13849-1) (Category 4), JIS C 0508-1 to 7 (SIL3)
- UL 61496-1/2 (Type 4), UL 1998, CSA C22.2 No.14, CSA C22.2 No.0.8
- OSHA 1910.212, OSHA 19 10.217(C), ANSI B11.1 to B11.19, ANSI/RIA 15.06, ANSI/ISA S84.01 (SIL3)



◆ NOTE

- **Conformity to JIS, OSHA and ANSI for this device has been evaluated by us.**



- **CE**: This device conforms to the EMC directive and the Machinery directive. The CE-mark indicates that this product conforms to the EMC directive.



- **TUV SUD**: This device is certified by TÜV Süd.



- **C-UL US**: The C-CL US Listing Mark indicates compliance with both Canadian and U.S. requirements.
- **If you want to use this device in a location other than already described (see page 3), confirm first that the intended use complies with the standards or regulations applicable in your region or country.**

Chapter 2

Before Using this Device





2.1 Features

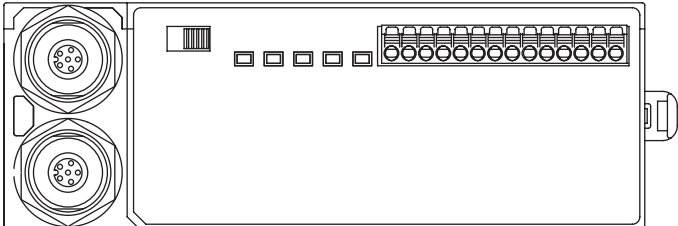
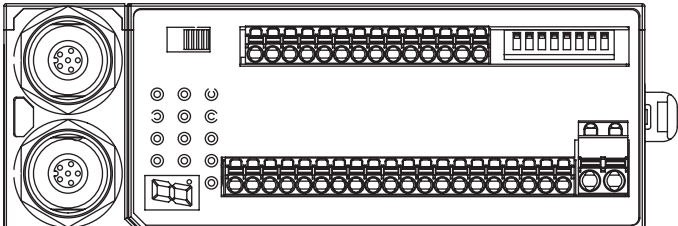
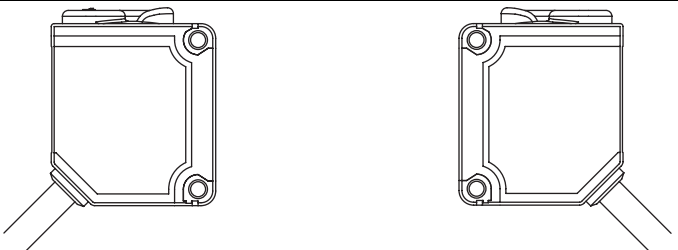

This device is a safety beam sensor with the following features.

- The controller ST4-C11 or the multifunctional controller ST4-C12EX is used in combination with the single-beam sensor ST4-A□.
- The type ST4-A□V comes with an emission amount adjuster to reduce the emission amount.
- Up to six units of the ST4-A□ can be connected per controller. The controller has an automatic interference prevention function.
- Wiring can be easily done by using the extension cable ST4-CCJ□ (optional) and the branch cable ST4-CCJ05-WY (optional), since the cables are connector types.
- The control output (OSSD 1/2) is a PNP/NPN output switching type. The output type can be switched with the output polarity selection switch on the controller.
- Replacing the relay is not necessary since a semiconductor output is used.
- The muting function complying with ISO 12643 (safety requirements for graphic technology equipment and systems) is available on the ST4-C12EX. For details, refer to the Muting Function (see page 59).

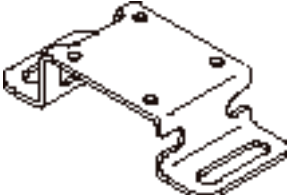
2.2 Part Description

The ST4 system can be built up from the following parts. Which controller type you choose depends on your requirements and applications.

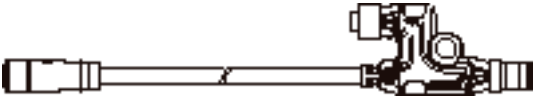
Part name	Part
Controller ST4-C11	
Multifunctional Controller ST4-C12EX	
	<div style="display: flex; justify-content: space-around;"> Emitter Receiver </div>
Emitter ST4-A and Receiver ST4-A	
Back angled mounting bracket (optional)	
Foot angled mounting bracket (optional)	
Foot biangled protective mounting bracket (optional)	
Extension cable ST4-CCJ	

Part name	Part
(optional)	
Branch cable ST4-CCJ-WY (optional)	
Slit mask (optional)	

2.2.1 Elements of the Controller ST4-C11

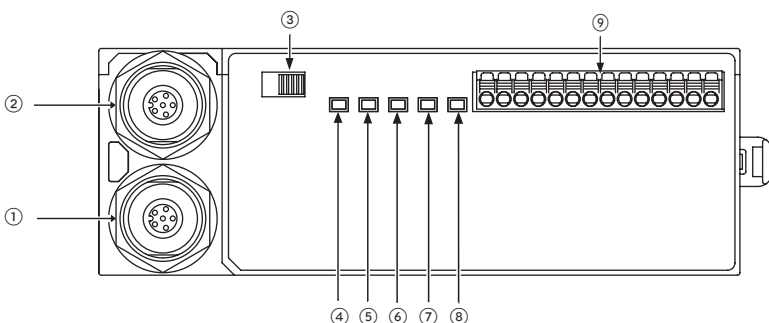

Identifier	Function
① Emitter connector	Connects the emitter of the ST4-A□.
② Receiver connector	Connects the receiver of the ST4-A□.
③ Output polarity selection switch	Switches the control output to PNP output or NPN output.
④ Power indicator (Green)	Lights up while power is ON.
⑤ Control output indicator (Green)	Lights up while the control output (OSSD 1/2) is ON.
⑥ Interlock indicator (Yellow)	Lights up while the interlock is ON. Turns OFF when an error occurs or the control output (OSSD 1/2) is ON.
⑦ Emission halt indicator (Orange)	Lights up while the emission halt function is valid.
⑧ Fault indicator	Lights up or blinks when an error occurs. For details, refer to "Troubleshooting (see page 79)".
⑨ Terminal block	See the following table.

Terminal block

Terminal name	Description
IL+	Interference prevention terminals (downstream)
IL-	For details, refer to "Interference Prevention Function see "Interference Prevention Function" on page 54".
IU+	Interference prevention terminals (upstream)
IU-	For details, refer to Interference Prevention Function see "Interference Prevention Function" on page 54.

Terminal name	Description
X1	Reset input terminals (When X1 and X2 are connected: manual reset, and when X1 and X3 are connected: auto reset)
X2	
X3	
T1	Emission halt input terminals (Open: emission halt, Short-circuit: emission)
T2	
AUX	
OSSD 1	Control output (OSSD 1/2)
OSSD 2	
A1	
A2	

2.2.2 Elements of the Multifunctional Controller ST4-C12EX

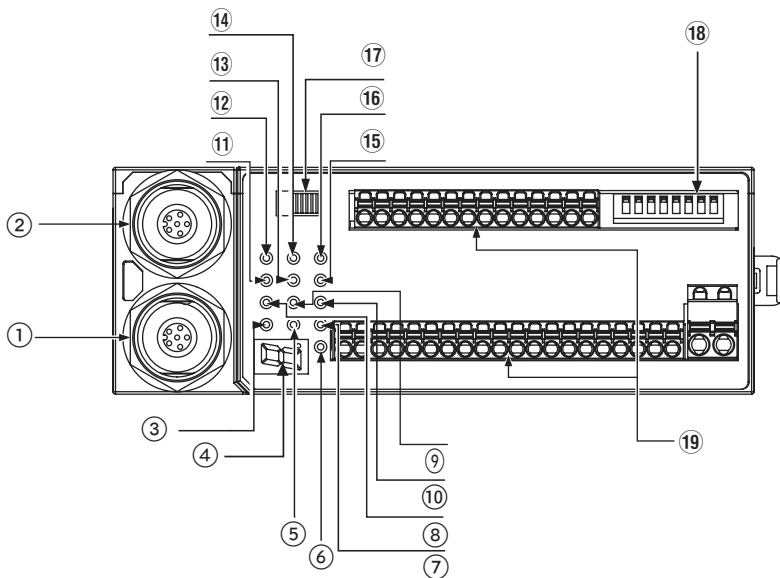

Identifier	Function
① Emitter connector	Connects the emitter of the ST4-A□.
② Receiver connector	Connects the receiver of the ST4-A□.
③ Power indicator (Green)	Lights up while power is ON.
④ Fault display (Red)	7-segment lights up when an error occurs. For details, refer to Troubleshooting (see page 79).
⑤ Interlock indicator (Yellow)	Lights up while the interlock is ON. Turns OFF when an error occurs or the control output (OSSD 1/2) is ON.
⑥ Emission halt indicator (Orange)	Lights up while the emission halt function is valid.
⑦ Control output indicator	Lights up while the control output (OSSD 1/2) is ON.

	Identifier	Function
	(Green)	
⑧	Auxiliary output 1 indicator (Orange)	Turns OFF while the muting function is valid. Lights up while the muting function is invalid.
⑨	Auxiliary output 2 indicator (Orange)	Turns OFF while the override function is valid. Lights up while the override function is invalid.
⑩	Auxiliary output 3 indicator (Orange)	Lights up when the muting lamp is in normal operation. Turns OFF when the muting lamp is in error.
⑪	Muting input S-A indicator (Orange)	Lights up when the sensor input connected to the muting input terminal (S-A) is ON.
⑫	Muting input S-B indicator (Orange)	Lights up when the sensor input connected to the muting input terminal (S-B) is ON.
⑬	Muting input S-C indicator (Orange)	Lights up when the sensor input connected to the muting input terminal (S-C) is ON.
⑭	Muting input S-D indicator (Orange)	Lights up when the sensor connected to the muting input terminal (S-D) is input ON.
⑮	Muting input S-E indicator (Orange)	Lights up when the sensor input connected to the muting input terminal (S-E) is ON.
⑯	Muting input S-F indicator (Orange)	Lights up when the sensor input connected to the muting input terminal (S-F) is ON.
⑰	Output polarity selection switch	Switches the control output to PNP output or NPN output.
⑱	DIP switches	 See the table "DIP switches".
⑲	Terminal block	See table "Terminal block".

DIP Switches

No.	Description
1 to 4	Sets the ST4-A□ into the muting state. Sets effective time for muting/override (see page 59).
5	Checks the states "beam received" and "beam interrupted" of the connected ST4-A□, or a sensor error (see "Sensor Diagnosis Function (Only ST4-C12EX)" on page 71).
6	Unused
7	
8	Deactivates the muting lamp diagnosis function (see page 74).

Terminal block

Terminal Name	Description
S+	Muting input power supply (24V)
S-A	Muting input S-A (for PNP type)
S-B	Muting input S-B (for NPN type)
S-	Muting input power supply (0V)
S+	Muting input power supply (24V)
S-C	Muting input S-C (for PNP type)
S-D	Muting input S-D (for NPN type)
S-	Muting input power supply (0V)
S+	Muting input power supply (24V)
S-E	Muting input S-E (for PNP type)
S-F	Muting input S-F (for NPN type)
S-	Muting input power supply (0V)
AUX1	Auxiliary output 1 (muting function)
AUX2	Auxiliary output 2 (override function)
AUX3	Auxiliary output 3 (lamp shutoff)
AUX4	Negative logic of the control output (OSSD 1/2)
OSSD 1	Control output (OSSD 1/2)
OSSD 2	
L1	Muting lamp connecting terminals
L2	
A	
A2	
IL+	Interference prevention terminals (downstream)
IL-	For details, refer to Interference Prevention Function see "Interference Prevention Function" on page 54.
IU+	Interference prevention terminals (upstream)
IU-	For details, refer to Interference Prevention Function see "Interference Prevention Function" on page 54.
O1	Override input terminals
O2	
X1	Reset input terminals:
X2	When X1 and X2 are connected: manual reset
X3	When X1 and X3 are connected: auto-reset
T1	Emission halt input terminals (open: emission halt, short-circuit: emission)
T2	

2.2.3 Elements of the Sensor ST4-A

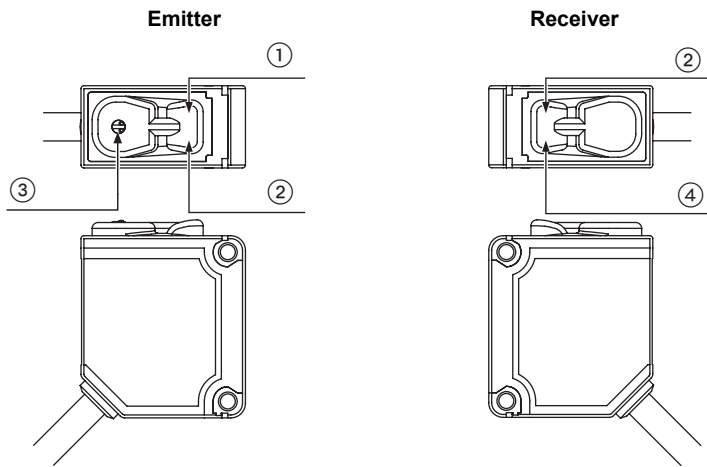

	Identifier	Function
①	Beam emission indicator (Green)	Lights up during beam emission of the sensor. Turns off during emission halt of the sensor.
②	Beam interruption indicator (Red)	Lights up during beam interruption of the sensor. Lights up during lock out. Turns off during beam reception of the sensor.
③	Emission amount adjuster (Note 1)	Adjusts the emission amount. For details, refer to Operation Test (see page 46) or Emission Amount Adjustment Function (see page 57).
④	Stable incident beam indicator (Green)	Lights up when incident beam intensity is over 150%. (Note 2) Turns off when incident beam intensity is 150% or less. (Note 2)



◆ **NOTE**

1. Only available with the ST4-A□V type.
2. The incident beam intensity that turns the control output (OSSD 1/2) to ON is regarded as 100%.

2.3 Protection Area

2.3.1 Sensing Range



DANGER!

Be sure to install a protective structure around the machine so that the operator must pass through the sensing area of the single beam sensor to reach the dangerous parts of the machine. Failure to do so can result in death or serious injury.

Do not use any reflection type or recursive reflection type arrangement.

Installing multiple sets of this device produces a non-sensing area or causes mutual interference, which may result in death or serious injury.

This example shows what a protective structure could be, where the dangerous part of a machine should be situated and how the emitter and receiver can be arranged.



◆ EXAMPLE

Installing four units of the ST4-A□

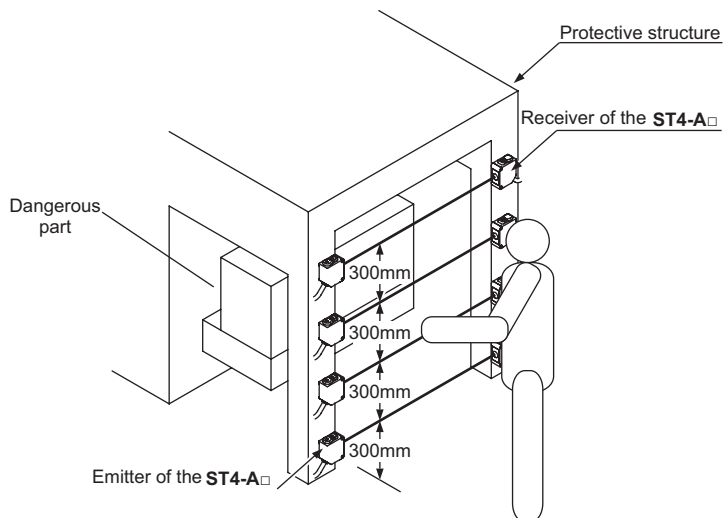

Top view

From the top view the safety distance between the sensing area and the dangerous part is clearly visible.

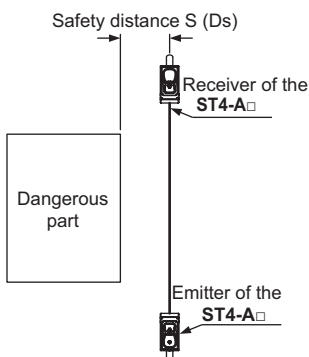

2.3.2 Safety Distance



DANGER!

Calculate the safety distance correctly, and always maintain a distance equal to or greater than the safety distance, between the sensing area of this device and the dangerous parts of the machine. If the safety distance is miscalculated or if sufficient distance is not maintained, the machine will not stop quickly before reaching to the dangerous parts, which can result in death or serious injury.

The safety distance is the minimum distance that must be maintained between the ST4-A and the dangerous parts of the machine so that the machine can be stopped before a human body or an object can reach the dangerous parts.

The safety distance is calculated based on the equation (see page 17) when a person moves perpendicular to the sensing area of the area sensor.



CAUTION

- Before designing the system, refer to the relevant standards of the region where the single beam sensor is to be used.
- The equation should only be used when the intrusion direction is perpendicular to the sensing area. If the intrusion direction is not perpendicular to the sensing area, be sure to refer to the relevant standard (regional standard, specification of the machine, etc.) for details of the calculation.
- The max. response time of the machine is from the point when the machine receives the halt signal from this device to the point when the dangerous part of the machine stops. The max. response time of the machine should be timed with the machine actually used.

2.3.2.1 Calculation Example for Europe

The minimum safety distance S is calculated in accordance with EN 999 and ISO 13855 with the following equation:

$$S = K \times T + C$$

S: Safety distance (mm)

Minimum distance required between the sensing area surface and the dangerous parts of the machine.

K: Intrusion velocity of operator's body or object (mm/s). The equation assumes an intrusion direction perpendicular to the sensing area. The recommended value is 1600 mm/s.

T: Response time of total equipment (s). $T = T_m + T_{ST4}$

T_m : Maximum halt time of the machine (s). To determine T_m , refer to the machine documentation or take a measurement using a special device called a "brake monitor".

T_{ST4} : Response time of the safety beam sensor (s).

C: Additional distance (mm).

Depending on the height of the beam axis EN 999 recommends different additional distances as shown in the following table.

Number of beam axes	1	2	3	4
Height of beam axis (e.g. height from the floor)	750 mm	400mm	300mm	300mm
		900mm	700mm	600mm
			1100mm	900mm
				1200mm
Additional distance	1200mm	850mm	850mm	850mm



◆ EXAMPLE

Calculation of the safety distance (S) with the following values and four units of the ST4-A□ installed.

K: 1600mm/s

T_m : 0.1s

T_{ST4} : 0.025s

C: 850mm

$$\begin{aligned}
 S &= K \times T + C \\
 &= 1600 \times (T_m + T_{ST4}) + 850 \\
 &= 1600 \times (0.1s + 0.025s) + 850 \\
 &= 1600 \times 0.1s + 1600 \times 0.025 + 850 \\
 &= 160 + 40 + 850 \\
 &= 1050
 \end{aligned}$$

Hence, as per the calculations S is 1050mm.

2.3.2.2 Calculation Example for the US

The safety distance D_s is calculated in accordance with ANSI/RIA 15.06 with the equation:

$$D_s = K \times T + D_{pf}$$

D_s : Safety distance (mm)

Minimum required distance between the sensing area surface and the dangerous parts of the machine

K : Intrusion velocity of operator's body or object. The recommended value in OSHA is 63inch/s (≈ 1600 mm/s).

ANSI/RIA 15.06 does not define the intrusion velocity "K." When determining K, consider possible factors including the physical ability of the operators.

T : Response time of total equipment (s). $T = T_s + T_c + T_{ST4}$

T_s is the worst stopping time of the machine/equipment

T_c is the worst stopping time of the control system

T_{ST4} is the response time of the safeguarding device (25ms)

D_{pf} : Additional distance calculated from the size of the minimum sensing object of the sensor (mm).



◆ REFERENCE

Since the calculation is based on 1 inch = 25.4mm, there is a slight difference between the representation in mm and that in inches. Refer to the relevant standard for the details.

Example calculation of the safety distance for a "REACH OVER" application

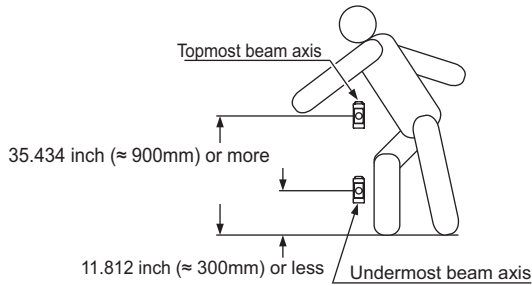

The following default values of ANSI/RIA 15.06 are used for the example calculation:

Detectable minimum sensing object	Min. 2.52inch (≈ 64mm) and max. 23.623inch (≈ 600mm)
Undermost beam axis:	11.812inch (≈ 300mm) or less
Topmost beam axis	35.434inch (≈ 900mm) or more
T	0.5s
D _{pf}	47.245inch (≈ 1200mm)

$$\begin{aligned}
 D_s &= K \times T + D_{pf} \\
 &= 63 \times T + 47.245 \\
 &= 63 \times 0.5 + 47.245 \\
 &= 31.5 + 47.245 \\
 &= 78.745\text{inch} \\
 &= 2000.123\text{mm} \\
 &\approx 2001\text{mm}
 \end{aligned}$$

Hence $D_s = 2001\text{mm}$.



◆ REFERENCE

Since the calculation is based on 1 inch = 25.4mm, there is a slight difference between the representation in mm and that in inches. Refer to the relevant standard for the details.

Example calculation of the safety distance for a "REACH THRU" application

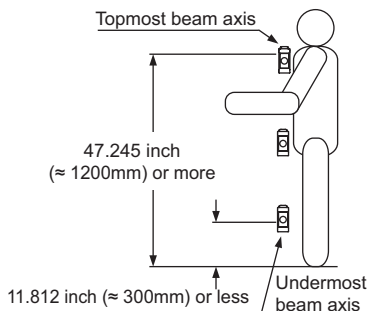

The following default values of ANSI/RIA 15.06 are used for the example calculation:

Detectable minimum sensing object	Min. 2.52inch (\approx 64mm) and max. 23.623inch (\approx 600mm)
Undermost beam axis	11.812inch (\approx 300mm) or less
Topmost beam axis	47.245inch (\approx 1200mm) or more
T	0.5s
D_{pf}	35.434inch (\approx 900mm)

$$\begin{aligned}
 D_s &= K \times T + D_{pf} \\
 &= 63 \times T + 35.434 \\
 &= 63 \times 0.5 + 35.434 \\
 &= 31.5 + 35.434 \\
 &= 66.934\text{inch} \\
 &= 1700.1236\text{mm} \\
 &\approx 1701\text{mm}
 \end{aligned}$$

Hence $D_s = 1701\text{mm}$.



◆ REFERENCE

Since the calculation is based on 1 inch = 25.4mm, there is a slight difference between the representation in mm and that in inches. Refer to the relevant standard for the details.

2.3.3 Influence of Reflective Surfaces



DANGER!

If a reflective surface exists where this device is to be installed, make sure to install this device so that reflected light from the reflective surface does not enter the receiver. Alternatively, take countermeasures such as painting, masking, roughening, or changing the material of the reflective surface, etc. Failure to do so may cause the device not to detect, resulting in serious injury or death.

Install this device at a distance of at least A m (provided as follows) away from reflective surfaces such as metal walls, floors, ceilings, work pieces, covers, panels or glass surfaces.

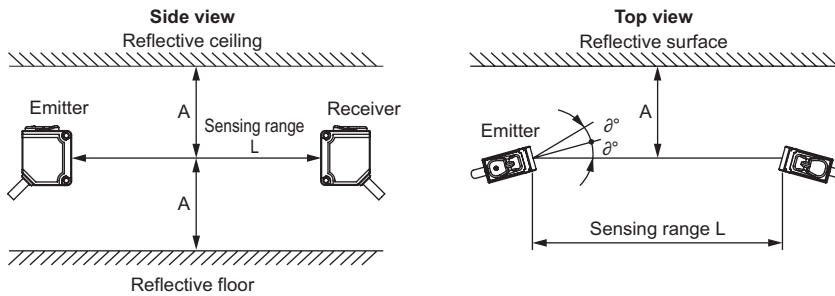

Distance between emitter and receiver (sensing range L)	Allowable installation distance A
0.1 to 3m	0.16m
3 to 15 m	$L/2 \times \tan 2\theta = L \times 0.053m (\theta = 3^\circ)$



◆ **NOTE**

The effective aperture angle for this device is $\pm 2.5^\circ$ (when $L > 3m$) as required by IEC 61496-2/UL 61496-2. However, install this device away from reflective surfaces, taking into consideration an effective aperture angle of $\pm 3^\circ$ to account for beam misalignment during installation.

Allowable distance from sensor beam axis to reflective surface

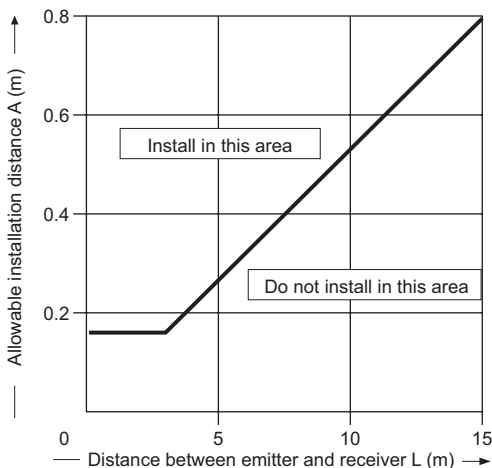

2.3.4 Placement of Emitter and Receiver

You can install a system in which multiple sets of controllers and their respective sensors face each other. Use this configuration if there is a problem in wiring or additional equipment has to be protected. If you arrange multiple sets, perform an operation test (see page 46).



DANGER!

Refer to the examples of device placement as follows and understand them thoroughly before installation. Improper placement could cause device malfunction, which can result in serious injury or death.

If this device is used in multiple sets, avoid mutual interference. If mutual interference occurs, it can result in serious injury or death.



◆ EXAMPLE

Arrangement of the emitter and receiver back to back:

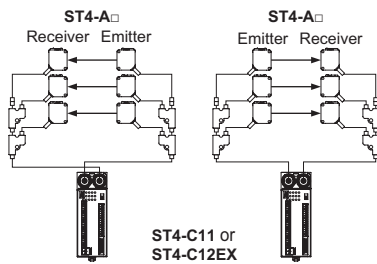

Arrangement of the emitter and receiver vertically on opposite sides:

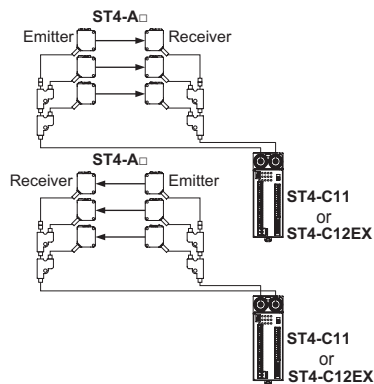

Arrangement of the emitter and receiver horizontally on opposite sides

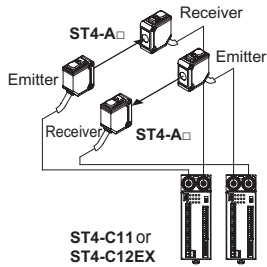

Installation of a barrier

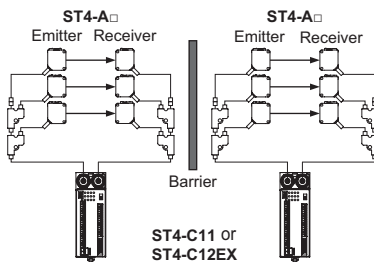

◆ NOTE

The preceding arrangements are just examples of device placement. If there are any questions or problems, please contact our office.

2.3.5 Connecting Multiple Sensors Heads

You can connect up to six units of the ST4-A□ per controller.

The cable length between all emitters and the controller, as well as between all receivers and the controller, must not exceed 50m, respectively.



DANGER!

If you hook up the connectors incorrectly or mix connecting the emitters and receivers, the device will not operate properly. This may result in serious injury or death.

The cable length between all emitters and the controller, as well as between all receivers and the controller, must not exceed 50m, respectively. If this length is exceeded it leads to improper operation of the device, resulting in serious injury or death.



◆ EXAMPLE

Six sensor units can be connected, whereas the following cables are used:

A1 + A2 + A3 + A4 + A5 + A6 + B1 + B2 + B3 + B4 + B5 + B6

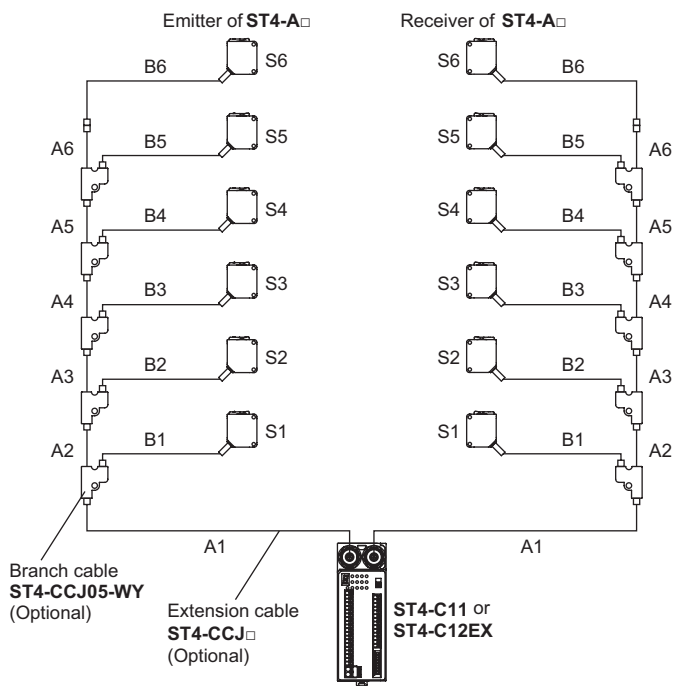

◆ Procedure

1. Insert the male emitter connector of the ST4-A□ (color: gray) into the female emitter connector of the controller (color: gray).
2. Insert the male receiver connector of the ST4-A□ (color: black) into the female receiver connector of the controller (color: black).

3. Make sure to use the optional exclusive cable (ST4-CCJ□, ST4-CCJ05-WY) for wiring, and match the connector colors (gray: emitter, black: receiver).
4. After installing the ST4-A□, check that the ST4-A□ detects a part of human body before it reaches to the dangerous part of the machine, by watching the beam interruption indicator (red).
5. Check that the ST4-A□ is installed in the proper position.

2.3.6 Address Allocations of the Sensor ST4-A□

When connecting multiple units of the ST4-A□, addresses are automatically allocated to the newly connected units of the ST4-A□, beginning with the unit closest to the controller.

The corresponding emitter and receiver have the same address (see following example).

The automatic interference prevention function is based on the address of the sensors.



Ensure that the emitter and the receiver operate only in combination with the same address.



Connection example 1: No branching between the ST4-A□ and the ST4-CCJ05-WY when six units are connected

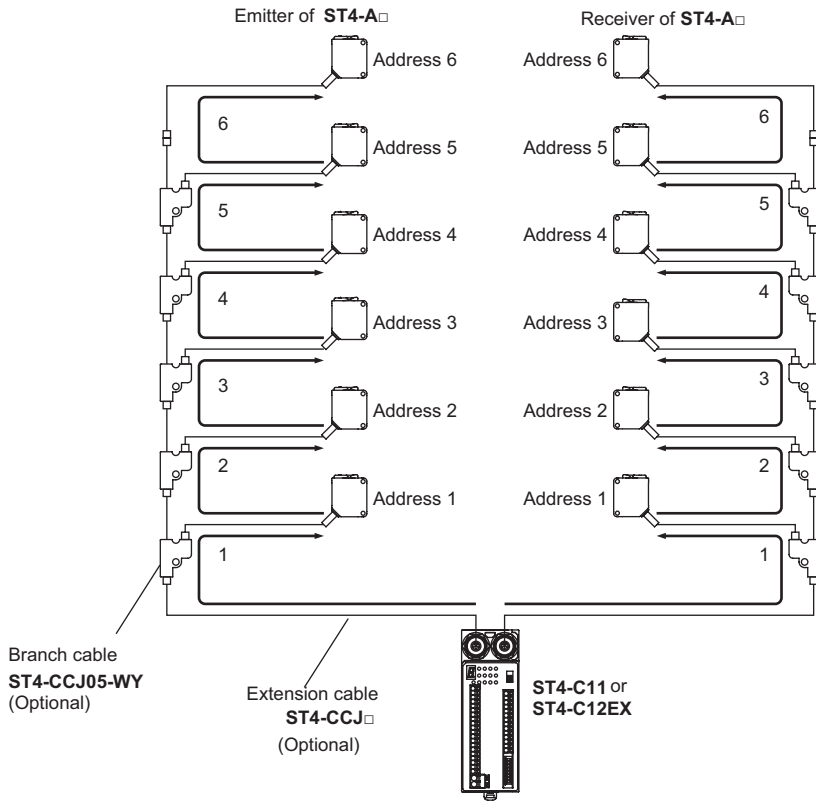

◆ NOTE

Addresses are automatically allocated in the order of the arrows shown in the preceding figure.



◆ EXAMPLE

Connection example 2: Branching between the ST4-A□ and ST4-CCJ05-WY when six units are connected

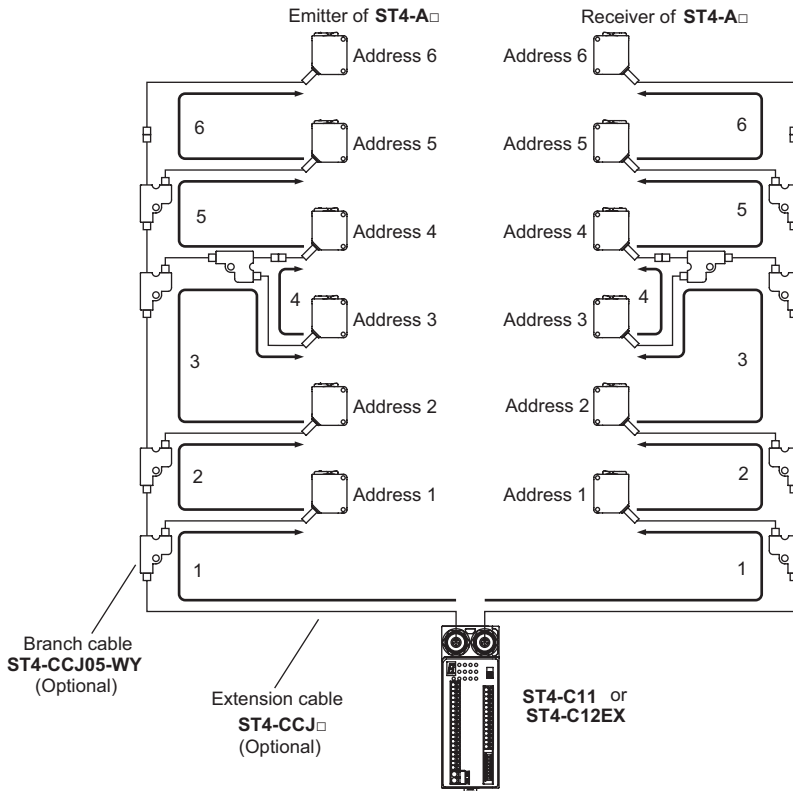

◆ NOTE

- Addresses are automatically allocated in the order of the arrows shown in the preceding figure.
- Addresses of the ST4-A□ are allocated in the order of the numbers that are marked on the main body of ST4-CCJ05-WY (optional).

- **Connect the ST4-A□s to the connector numbers 2 and 3 of the branch cable ST4-CCJ05-WY (optional). If the ST4-A□s are not connected to the connectors 2 and 3, the device will not operate properly. For an unconnected condition, the fault indicator (yellow) of ST4-C11 blinks once. For ST4-C12EX, " / " is indicated on the fault display (red).**

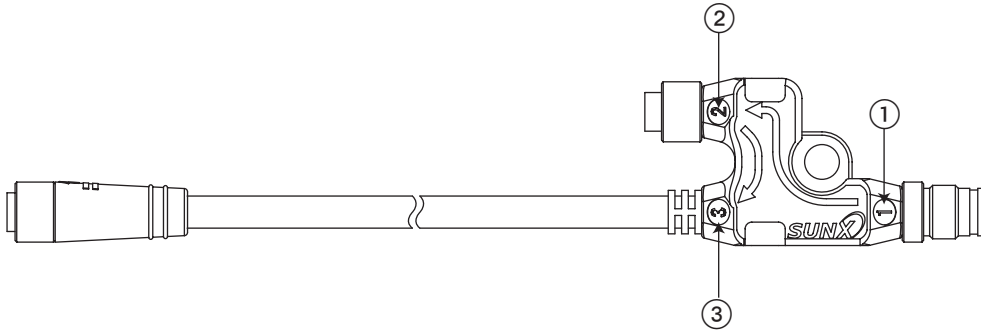

2.4 Mounting and Removing

2.4.1 Mounting and Removing the Controller

The controller can be mounted on a 35mm width DIN rail.



◆ Procedure

1. Push the DIN rail stopper.
2. Fit the tab on the opposite side of the DIN rail stopper onto the DIN rail.
3. Press the device into place.

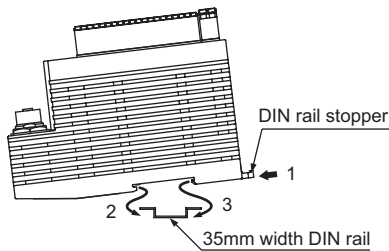

Remove the controller.



◆ Procedure

1. Insert a flathead screwdriver into the groove of the DIN rail stopper and pull out the stopper.
2. Push the controller in the opposite direction.
3. Lift and remove the controller.

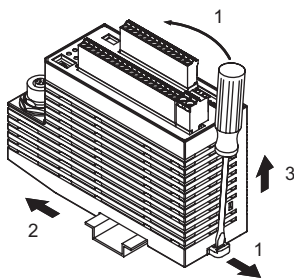

◆ CAUTION

Removing the controller without unlocking the DIN rail stopper may cause the tabs to break.

2.4.2 Mounting the Sensor ST4-A□

Select the sensor mounting bracket based on the installation environment. The mounting bracket is not included with this device. Please purchase the optional sensor mounting bracket that fits with the mounting environment.



DANGER!

After installing the ST4-A□, check that the ST4-A□ detects a part of human body before it reaches to the dangerous part of the machine, by watching the beam interruption indicator (red).

Also check that ST4-A□ is installed in a proper position.



CAUTION

- Do not apply an improper load such as forcibly bending the cable of the single-beam sensor, because the wire could break.
- The minimum bending radius of the cable is R5mm. When mounting, consider the cable bending radius.



NOTE

- Mount the emitter and the receiver at the same level and parallel to each other. The effective aperture angle of this device is $\pm 2.5^\circ$ or less for a sensing distance of 3m or more.
- In preparation for mounting, prepare mounting holes on the mounting surface (see "Dimensions" on page 95).

The following procedure shows the mounting of the single-beam sensor with the mounting bracket MS-CX1.



Procedure

1. Mount the sensor with the M3 screws with washers (length 12mm) attached to the sensor mounting bracket (optional).

The tightening torque should be 0.5N·m or less.

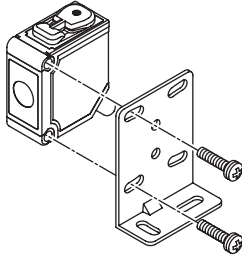

2. Mount the sensor on the mounting surface with M3 screws with washers.

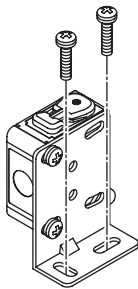

2.4.3 Connecting Controller and Sensor ST4-A□



DANGER!

If you hook up the connectors incorrectly or mix connecting the emitters and receivers, the device will not operate properly. This may result in serious injury or death.

The emitter of the ST4-A□ (connector color: gray) has to be connected with the emitter connector of the controller (connector color: gray). The receiver of the ST4-A□ (connector color: black) has to be connected with the receiver connector of the controller (connector color: black).



◆ CAUTION

- Make sure to turn OFF the power before connecting disconnecting the cables.
- Securely tighten by hand the fixing ring on the emitter or receiver of the ST4-A□.
- If the fixing ring on the emitter/receiver of the ST4-A□ is tightened with pliers, the connector may be damaged.
- If the tightening torque is insufficient, the fixing ring on the emitter or receiver of the ST4-A□ may loosen due to vibrations, etc.

Connecting the single-beam sensor with the controller:



◆ Procedure

1. Insert the male connector of the ST4-A□ in connector of the controller.
2. Turn the fixing ring to tighten.

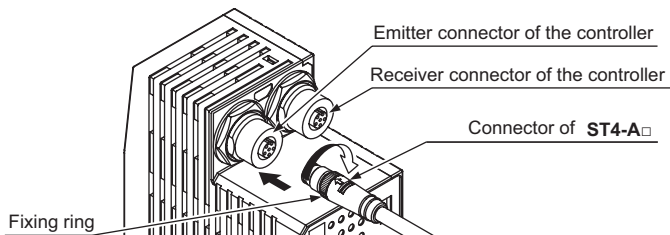

Disconnecting



◆ Procedure

1. Loosen the fixing ring.
2. Pull out the connector by holding the fixing ring.

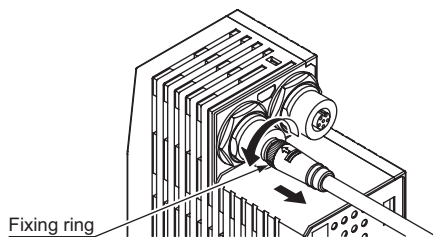

◆ CAUTION

- Before removing the connectors, make sure that the fixing rings are fully loosened.
- If the connectors are forcibly pulled out with the fixing rings tightened, the connectors may be damaged.

2.4.4 Series Connection of the Sensor ST4-A□

You can connect up to six units of the ST4-A□ per controller in series.

When connecting several sensors, the extension cable ST4-CCJ□ (optional) and the branch cable ST4-CCJ05-WY (optional) are needed. Please purchase them separately.

**DANGER!**

If you hook up the connectors incorrectly or mix connecting the emitters and receivers, the device will not operate properly. This may result in serious injury or death.

The cable length between all emitters and the controller, as well as between all receivers and the controller, must not exceed 50m, respectively. If this length is exceeded it leads to improper operation of the device, resulting in serious injury or death.

After installing the ST4-A□, check that the ST4-A□ detects a part of human body before it reaches to the dangerous part of the machine, by watching the beam interruption indicator (red). Also check that ST4-A□ is installed in a proper position.

The emitter of the ST4-A□ (connector color: gray) has to be connected with the emitter connector of the controller (connector color: gray). The receiver of the ST4-A□ (connector color: black) has to be connected with the receiver connector of the controller (connector color: black).

**◆ NOTE**

- Addresses of the ST4-A□ are allocated in the order of the numbers that are marked on the main body of ST4-CCJ05-WY (optional).
- Connect the ST4-A□s to the connector numbers 2 and 3 of the branch cable ST4-CCJ05-WY (optional). If the ST4-A□s are not connected to the connectors 2 and 3, the device will not operate properly. For an unconnected condition, the fault indicator (yellow) of ST4-C11 blinks once. For ST4-C12EX, "!" is indicated on the fault display (red).

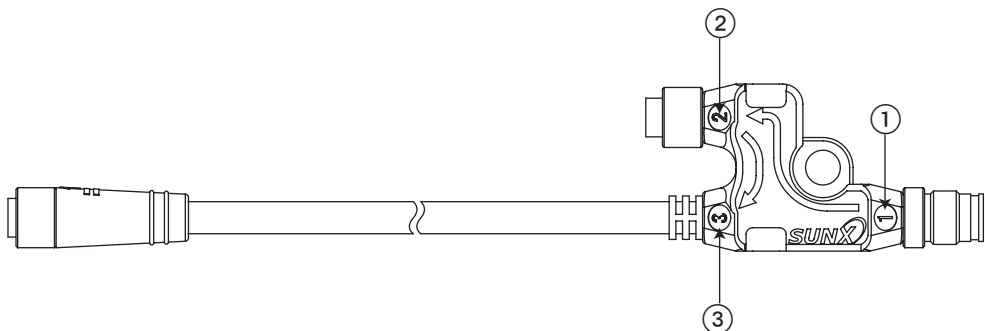

To connect the sensor in series, you need at least two sets of receiver and emitter of the ST4-A□, two extension cables ST4-CCJ□s and two branch cables ST4-CCJ05-WY.

**◆ Procedure**

1. Insert the male connectors of the extension cables ST4-CCJ□s into the connector of the controller, and turn the fixing ring to fix.

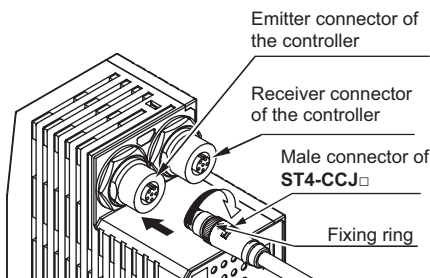

2. Insert connector no. 1 of the branch cables ST4-CCJ05-WY into the female connectors of both extension cables ST4-CCJ□, and tighten the fixing ring.

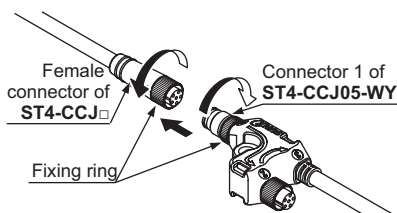

3. Insert the connector of the ST4-A□ into connector no. 2 of the branch cable ST4-CCJ05-WY, and tighten the fixing ring.

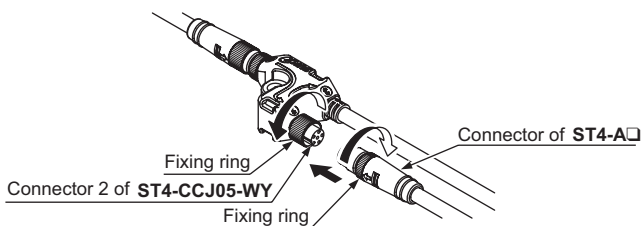

4. Insert the connector of the second set of the ST4-A□ into connector no. 3 of the branch cable ST4-CCJ05-WY, and tighten the fixing ring. If you want to connect further sensors, insert connector no.1 of the third and fourth branch cable ST4-CCJ05-WY to the connector no. 3 of first and second branch cable, and tighten the fixing rings. After that, repeat the procedures 3 and 4.

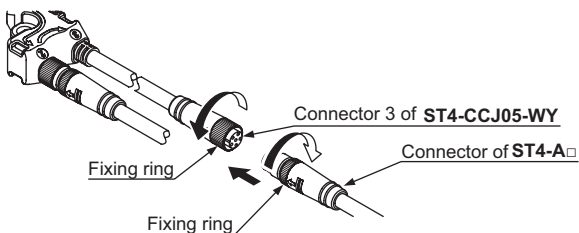

5. Use a M5 small pan head screw (please arrange separately) to mount ST4-CCJ05-WY.

The tightening torque should be 0.7N·m or less.

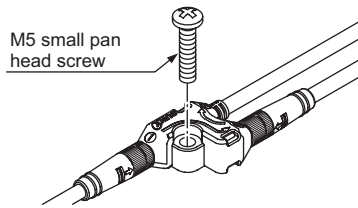

To remove the sensor:



◆ Procedure

1. Loosen the fixing ring.
2. Pull out the connector by holding the fixing ring.

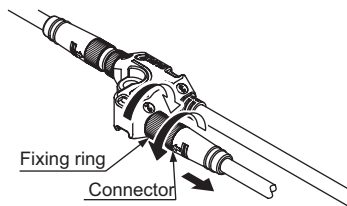

◆ CAUTION

- Before removing the connector, make sure that the fixing ring is fully loosened. If the connector is forcibly pulled out with the fixing ring tightened, the connector may be damaged.

2.5 Wiring

Read the following warnings carefully before wiring.



DANGER!

Switch off the power before wiring the device.

All electrical wiring should conform to the regional electrical regulations and laws. The wiring should be done by engineer(s) having the required electrical knowledge.

Do not run the sensor cable together with high-voltage lines or power lines or put them together in the same raceway.

Take countermeasures regarding the system to ensure that dangerous performance caused by the earth failure cannot occur. Failure to do so could cause jeopardize the system stop, resulting in serious bodily injury or death.

In order that the output is not turned ON due to earth fault of control output (OSSD 1/2) terminal, be sure to ground to the 0V side for PNP output or the 24V side for NPN output.



◆ NOTE

Use a safety relay unit or an equivalent control safety circuit for FSD.

2.5.1 Power Supply Unit

The wiring of the power supply unit should be performed by a specialist who has the required electrical knowledge.



DANGER!

Wire correctly and use a power supply unit which conforms to the laws and standards of the region where this device is to be used. If the power supply unit does not conform to regional requirements or the wiring is improper, may malfunction or be damaged, which can result in serious injury or death.

The DC power supply unit must satisfy the following conditions.

- The power supply unit must be authorized for use in the region where this device is to be used.
- The power supply unit must conform to the EMC Directive and Low-Voltage Directive

NPN output

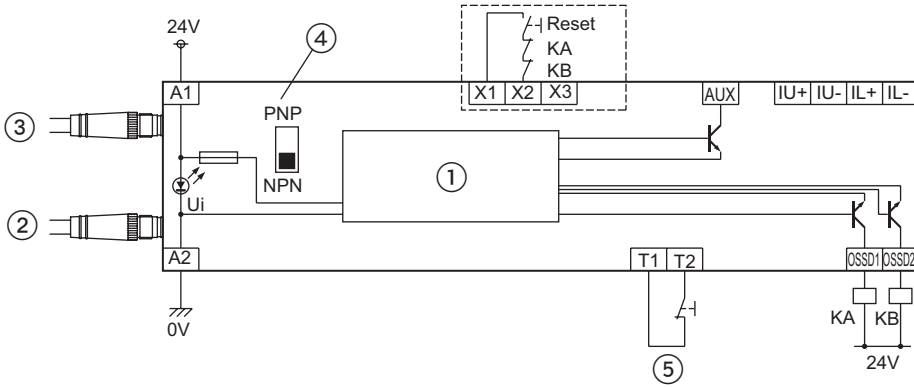

- ① = Main circuit
- ② = Emitter side
- ③ = Receiver side
- ④ = Output polarity switch
- ⑤ = Emission halt input



◆ NOTE

KA and KB are the external devices (forcibly guided relay or magnetic contactor).

2.5.2.2 Circuit of Multifunctional Controller ST4-C12EX

Multifunctional Controller ST4-C12EX

PNP output

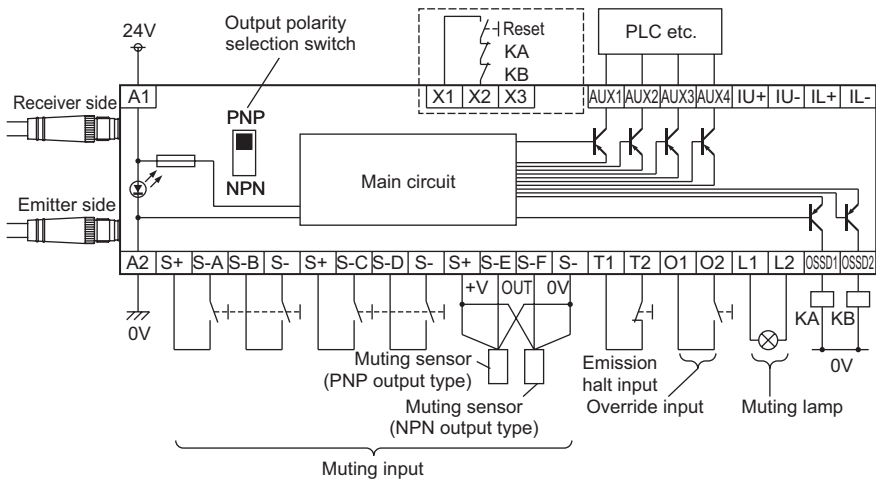

NPN output

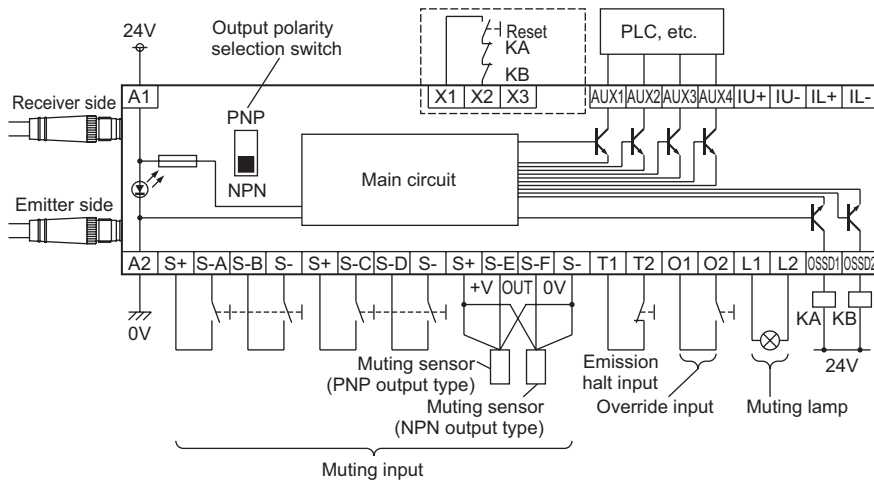

◆ NOTE

- KA and KB are the external devices (forcibly guided relay or magnetic contactor).
- When using the normally open (NO) contact switch as a muting sensor, wire as shown right.

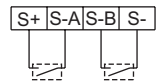

2.5.2.3 Manual and automatic reset

By wiring the reset input terminals (X1, X2, and X3) as shown, you can select a manual or an automatic reset, with or without back check.

Manual reset

When the back check circuit is needed:

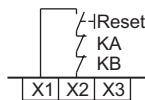

When the back check circuit is **not** needed:



Automatic reset

When the back check circuit is needed:

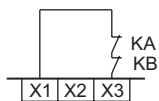

When the back check circuit is **not** needed:

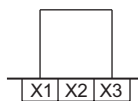

2.5.2.4 Emission Halt Input Terminals

The internal circuits of the emission halt input terminals (T1 and T2) as well as the override input terminals (O1 and O2) are switched by the output polarity selection switch.

Controller ST4-C11

PNP output

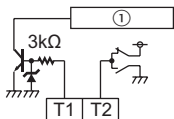

NPN output

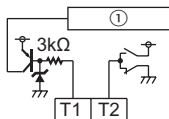

① = Main circuit

Controller ST4-C12EX

PNP output

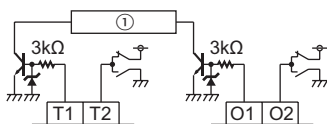

NPN output

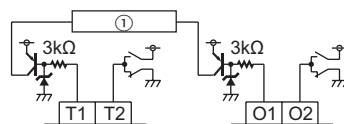

① = Main circuit

Output waveform (control output OSSD 1/2 ON)

Since the controller performs a self-diagnosis of the output circuit when the sensor is in light receiving status (ON), the output transistor periodically turns OFF (see following figure). If the preceding OFF signal is received by the controller the output circuit is judged as normal. If the OFF signal is not received, the controller judges either the output circuit or wiring as faulty, and the control output (OSSD 1/2) switches OFF.



Since the OFF signal of this device might cause malfunction, ensure that the input response time of the machine corresponds to the requirements of this device.

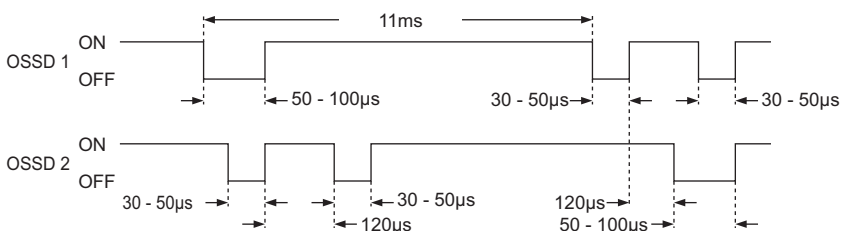

The values in the preceding picture are approximate values.

2.5.3 Connecting to the Terminal Block

For the connection with the terminal block of the controller, insert a solid wire or twisted wire (lead wire) with a ferrule into the hole till it stops. The wire is locked when properly inserted.

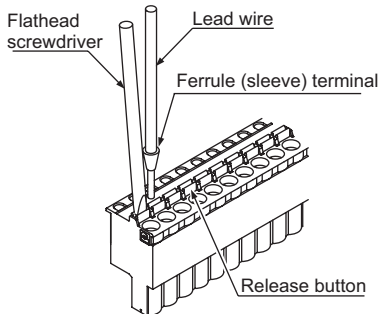

When connecting a twisted wire (lead wire) without a ferrule, insert the wire to the innermost of the terminal hole while pressing the release button.

If you want to release the solid wire or the twisted wire (lead wire), pull the wire while pressing the release button.



◆ CAUTION

However, do not pull the wire with excessive force, as this can cause a cable break.

The following wires are recommended:

- Terminal block connector: 0.2 to 1.5mm² (AWG 24 to 16)
- Power supply side connector (A1, A2) (ST4-C12EX only): 0.2 to 2.5mm² (AWG 24 to 12)

2.5.4 Terminal Arrangement Diagram

The following tables list the terminals of the controllers ST4-C11 and ST4-C12EX.

Controller ST4-C11

	<table border="1"> <thead> <tr> <th>Terminal name</th> <th>Description</th> </tr> </thead> <tbody> <tr> <td>IL+</td> <td rowspan="2">Interference prevention terminals (downstream) For details, see "Interference Prevention Function" on page 54.</td> </tr> <tr> <td>IL-</td> </tr> <tr> <td>IU+</td> <td rowspan="2">Interference prevention terminals (upstream) For details, see "Interference Prevention Function" on page 54.</td> </tr> <tr> <td>IU-</td> </tr> <tr> <td>X1</td> <td rowspan="3">Reset input terminals: <ul style="list-style-type: none"> • When X1 and X2 are connected: manual reset • When X1 and X3 are connected: auto-reset </td> </tr> <tr> <td>X2</td> </tr> <tr> <td>X3</td> </tr> </tbody> </table>	Terminal name	Description	IL+	Interference prevention terminals (downstream) For details, see "Interference Prevention Function" on page 54.	IL-	IU+	Interference prevention terminals (upstream) For details, see "Interference Prevention Function" on page 54.	IU-	X1	Reset input terminals: <ul style="list-style-type: none"> • When X1 and X2 are connected: manual reset • When X1 and X3 are connected: auto-reset 	X2	X3
Terminal name	Description												
IL+	Interference prevention terminals (downstream) For details, see "Interference Prevention Function" on page 54.												
IL-													
IU+	Interference prevention terminals (upstream) For details, see "Interference Prevention Function" on page 54.												
IU-													
X1	Reset input terminals: <ul style="list-style-type: none"> • When X1 and X2 are connected: manual reset • When X1 and X3 are connected: auto-reset 												
X2													
X3													

Terminal name	Description
T1	Emission halt input terminals (Open: emission halt, Short-circuit: emission)
T2	
AUX	Negative logic of the control output (OSSD 1/2)
OSSD 1	Control output (OSSD 1/2)
OSSD 2	
A1	24V DC
A2	0V

Multifunctional Controller ST4-C12EX

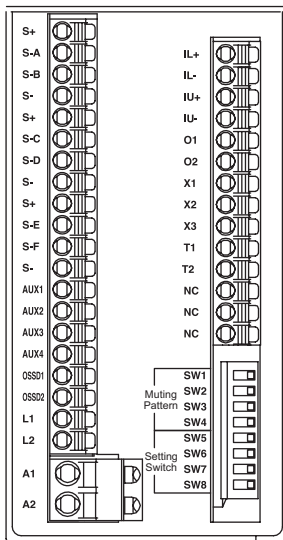

Terminal name	Description
S+	Muting input power supply 24V
S-A	Muting input S-A for PNP output type sensor
S-B	Muting input S-B for NPN output type sensor
S-	Muting input power supply 0V
S+	Muting input power supply 24V
S-C	Muting input S-C (for PNP type)
S-D	Muting input S-D (for NPN type)
S-	Muting input power supply 0V
S+	Muting input power supply 24V
S-E	Muting input S-E for PNP type
S-F	Muting input S-F for NPN type
S-	Muting input power supply 0V
AUX1	Auxiliary output 1 (muting function)
AUX2	Auxiliary output 2 (override function)
AUX3	Auxiliary output 3 (lamp shutoff)
AUX4	Negative logic of the control output (OSSD 1/2)
OSSD 1	Control output (OSSD 1/2)
OSSD 2	
L1	Muting lamp connecting terminal
L2	
A1	24V DC
A2	0V

Terminal name	Description
IL+	Interference prevention terminals (downstream) For details, see "Interference Prevention Function" on page 54.
IL-	
IU+	Interference prevention terminals (upstream) For details, see "Interference Prevention Function" on page 54.
IU-	

Terminal name	Description
O1	Override input terminals
O2	
X1	Reset input terminals: <ul style="list-style-type: none">• When X1 and X2 are connected: manual reset• When X1 and X3 are connected: auto-reset
X2	
X3	
T1	Emission halt input terminals: <ul style="list-style-type: none">• Open: emission halt• Short-circuit: emission
T2	

2.6 Adjustment and Operation

2.6.1 Beam-Axis Alignment



◆ Procedure

1. Turn ON the power supply unit of this device.
2. Check that the fault indicator (yellow) of the ST4-C11 or the fault display (red) of the ST4-C12EX is OFF.

If the following error occurs, see "Troubleshooting" on page 79 and report it and possible countermeasures to the maintenance staff in charge.

- ST4-C11: The fault indicator (yellow) lights up or blinks
- ST4-C12EX: An error is indicated on the fault display (red).

3. Move the emitter of the ST4-A□ vertically and horizontally in order to determine the range of light received with the help of the beam interruption indicator (red). Then fix the emitter in the center of this range.

The tightening torque should be 0.5N·m or less.

Loosen the M3 screws slightly between the ST4-A□ and the sensor mounting bracket (optional) to adjust the angle vertically.

Also, loosen the M3 screws slightly between the sensor mounting bracket and the mounting surface to adjust the angle horizontally.

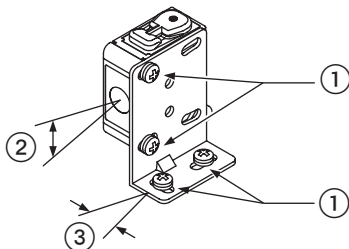

① = M3 screws with washers

② = Vertical adjustment

③ = Horizontal adjustment

For detailed information of the various sensor mounting brackets, refer to Dimensions (see "Dimensions" on page 95) to adjust the angle.

4. As you did for the emitter, perform the angular adjustment for the receiver of the ST4-A□.
5. Check that the beam interruption indicators (red) on the emitter and the receiver of the ST4-A□ are turned OFF. Also check that the stable incident beam indicator (green) of the receiver lights up.

When adjusting the angle between the emitter and the receiver of the ST4-A□, remember where the beam interruption indicators (red) of the emitter and the receiver turn OFF (both vertically and horizontally), and adjust the beam-axis to the position roughly in the center of the range. This makes detection more stable.

Vertical angle adjustment

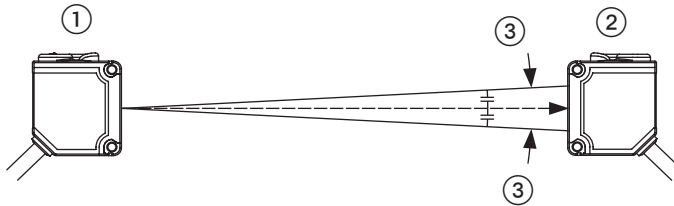

① = Emitter

② = Receiver

③ = Range where interruption indicators (red) turn off

Horizontal angle adjustment

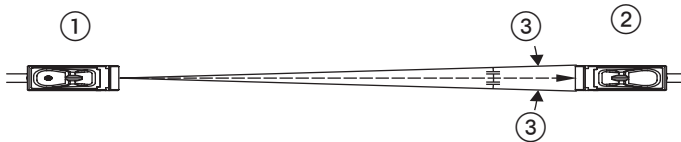

① = Emitter

② = Receiver

③ = Range where interruption indicators (red) turn off

2.6.2 Operation Test



DANGER!

The emission amount adjuster of the ST4-A□V is used to reduce the beam emission of the ST4-A□V to prevent influencing other sensors.

Do not use the emission amount adjuster of the ST4-A□V to prevent the reflection off surfaces. If it is used for such purposes and the emission amount adjuster is set at MAX., the reflection off surfaces increases. This may disable the sensor from detecting objects, which could result in serious injury or death.

To cope with reflective surfaces, see "Influence of Reflective Surfaces" on page 20 .

To test the installation:



◆ Procedure

1. Turn ON the power supply unit of this sensor.
2. Check that the fault indicator (yellow) of the ST4-C11 or the fault display (red) of the ST4-C12EX are OFF.

If the following error occurs, see (see "Troubleshooting" on page 79) and report it and possible countermeasures to the maintenance staff in charge.

- ST4-C11: The fault indicator (yellow) lights up or blinks
- ST4-C12EX: An error is indicated on the fault display (red).

3. When using the ST4-A□V, turn the emission amount adjuster on the emitter of the ST4-A□V to the position at MAX. side.

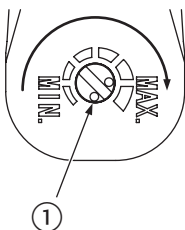

① = Emission amount adjuster

4. Check that the ST4-A□ is in the light beam received condition.
5. Check that the beam interruption indicators (red) on the emitter and receiver of the ST4-A□ light up by interrupting the light beam between the emitter and the receiver of the ST4-A□ by hand. Also, check that the control output indicator (green) on the controller is off.

In case that even if the light beam between the emitter and the receiver of the ST4-A□ is interrupted and the beam interruption indicator (red) on the emitter/receiver on the ST4-A□ does not light up, or the control output indicator (green) on the controller does not turn off, see (see "Troubleshooting" on page 79) and report the symptoms to the maintenance staff in charge.



◆ **NOTE**

If the indicators show reception of the light beam even though the beam is interrupted by hand, check whether there is a reflective object or extraneous light source near the sensor.

2.6.3 Operation

This device starts operation two seconds after the power is on. Configure the control system accordingly!

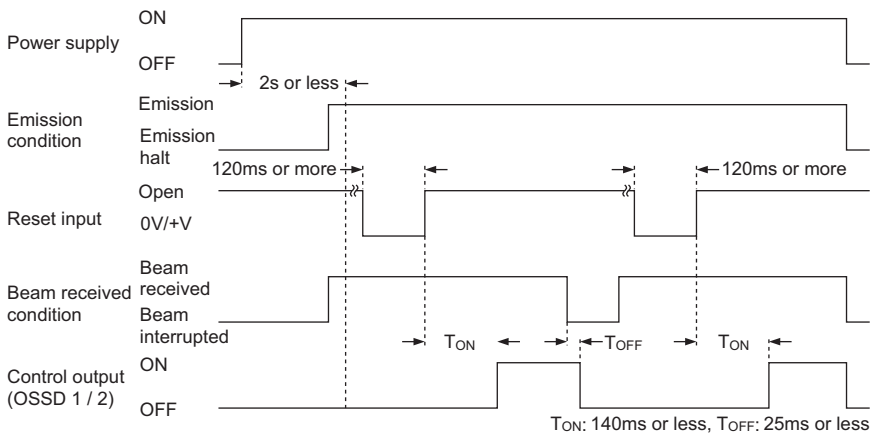

Timing chart for operation with manual reset

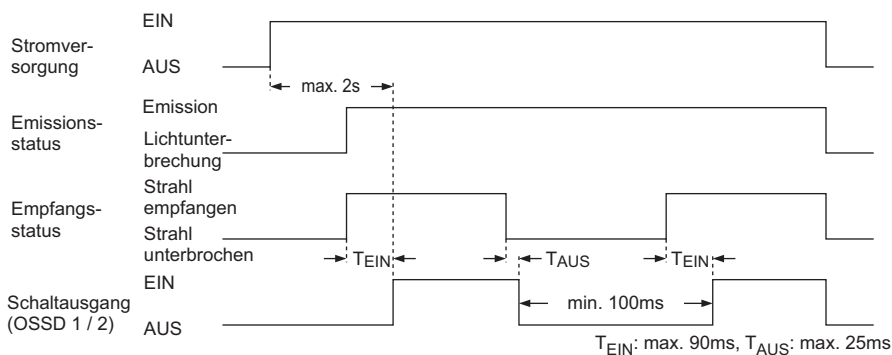

Timing chart for operation with automatic reset

Chapter 3

Functions

3.1 Self-Diagnosis Function

The controllers ST4-C11 and ST4-C12EX are equipped with a self-diagnosis function. Self-diagnosis is carried out periodically during operation.

In case an abnormality is detected during self-diagnosis, the sensor is immediately put in the lockout state and the control output (OSSD 1, OSSD 2) turns off. Find and remove the cause of abnormality (see page 79).

3.2 Reset Operation

Reset functionality is incorporated in the controllers ST4-C11 and ST4-C12EX. If the interlock function is activated for the control output (OSSD 1/2), you can reset the control output manually or automatically.

Manual and auto reset can be selected by wiring the reset input terminals (X1, X2, and X3) accordingly.

Terminals	Operation
X1-X2	Manual reset
X1-X3	Auto reset

3.2.1 Manual Reset



DANGER!

Install the reset switch outside of the dangerous area.

Install the reset switch where the staff in charge can see the whole dangerous area at all times.

For manual reset, keep the following aspects in mind:

- The control output (OSSD 1/2) is not turned ON automatically even if ST4-A□ receives the light beam.

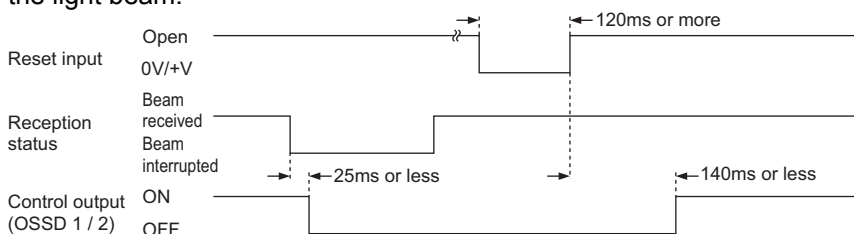

- The reset button and the back check circuit (KA, KB) are constructed between X1 and X2. When the back check circuit (KA, KB) is not required, only the reset button is constructed.

When the back check circuit is required

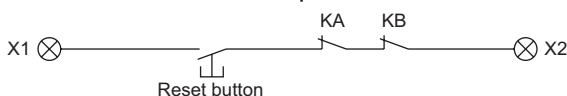

When the back check circuit is not required

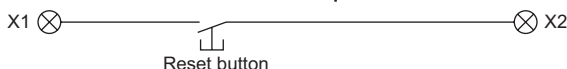

- The machine restarts at the start-up operation of the external reset button, assuming

ST4-A□ receives the light beam.

3.2.2 Auto Reset



DANGER!

If the auto-reset function is used and the control output (OSSD 1/2) is stopped, ensure that nothing else, such as a safety relay unit, executes an auto-restart of the system (EN 60204-1).

For automatic reset, keep the following aspects in mind:

- The control output (OSSD 1/2) turns on automatically when ST4-A□ receives the light beam.

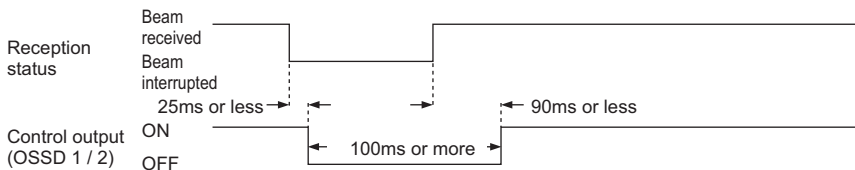

- The back check circuit (KA, KB) is constructed between X1 and X3. When the back check circuit (KA, KB) is not needed, short-circuit between X1 and X3.

When the back check circuit is required



When the back check circuit is not required



3.3 Emission Halt Function



WARNING!

Do not use the emission halt input to stop machinery! This could result in serious injury or death.

The emission halt input is incorporated in the controllers ST4-C11 and ST4-C12EX. This function stops the emission process of the ST4-A□. You can select whether emission is on or halted by wiring the terminals T1 and T2 as shown in the following table.

Between T1 and T2	Operation
Open	Emission halt
Short-circuit	Emission

During emission halt, the control output (OSSD 1/2) is off and the emission halt indicator (orange) lights up.

If the machinery is not stopped, the cause may be a malfunction due to extraneous noise or an abnormality in the control output (OSSD 1/2) or the auxiliary output, also from the machine.

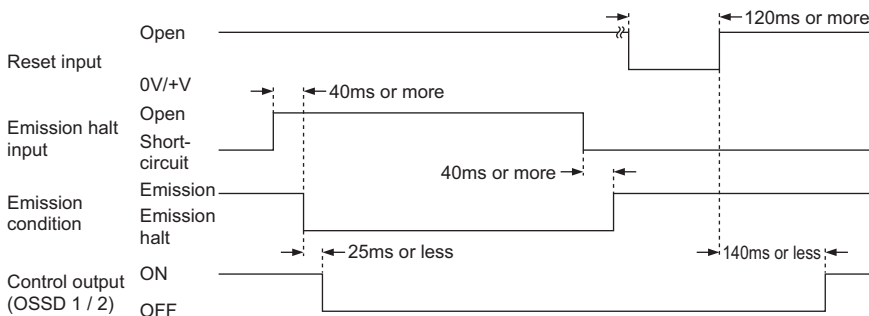

Time chart for manual reset

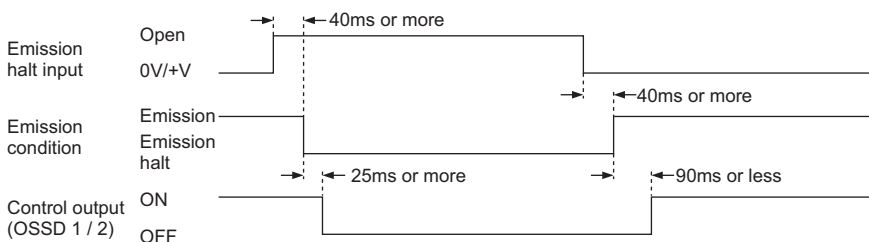

Time chart for auto reset

3.4 Interference Prevention Function

The interference prevention function is incorporated in both controllers ST4-C11 and ST4-C12EX.

3.4.1 Interference Prevention With One Controller

You can connect up to six units of the single beam sensor ST4-A□ per controller. Mutual interference can be prevented by the automatic interference prevention function incorporated into the controller.

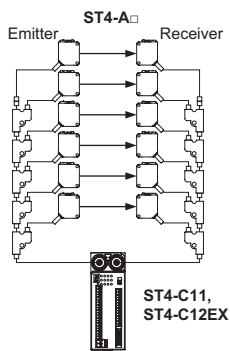

3.4.2 Interference Prevention Function When Using Two or More Controllers

You can connect up to six units of the single beam sensor ST4-A□ per controller. Mutual interference can be prevented for a maximum of three controller units.



◆ Procedure

1. Establish interference prevention by connecting the IL+ terminal of the first controller and the IU+ terminal of the second controller.
2. Connect the IL- terminal of the first controller and IU- terminal of the second controller.

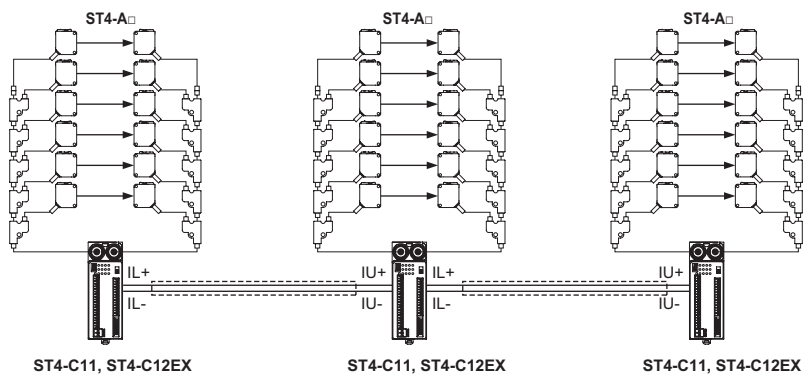
3. Connect the third controller in the same way.**◆ NOTE**

You can mix the controllers ST4-C11 and ST4-C12EX.

3.5 Auxiliary Output

The auxiliary output is a non-safety output which is incorporated in the controllers ST4-C11 and ST4-C12EX. It is reserved for non-safety-related purposes.

3.5.1 Auxiliary Output Operation of Controller ST4-C11

Terminal	Auxiliary output operation
AUX	Negative logic of the control output (OSSD 1/2)

3.5.2 Auxiliary Output Operation of Controller ST4-C12EX



DANGER!

Do not use the auxiliary output to stop the device. The result could be death or serious injury.

Terminal	Auxiliary output operation
AUX1	ON when the muting function is invalid. OFF when the muting function is valid.
AUX2	ON when the override function is invalid. OFF when the override function is valid.
AUX3	ON when the muting lamp is in the normal condition. OFF when the muting lamp is in an abnormal condition.
AUX4	Negative logic of the control output (OSSD 1/2)

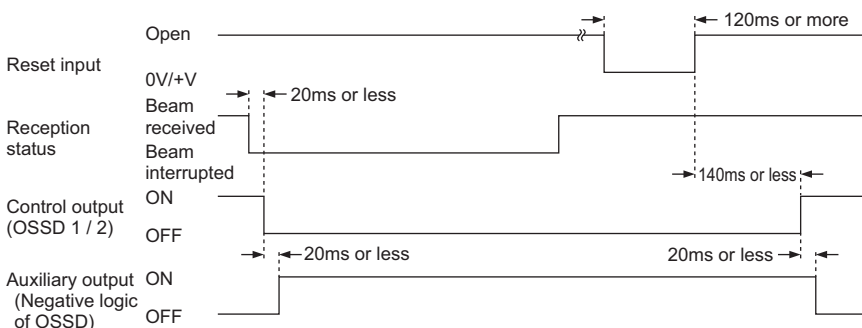

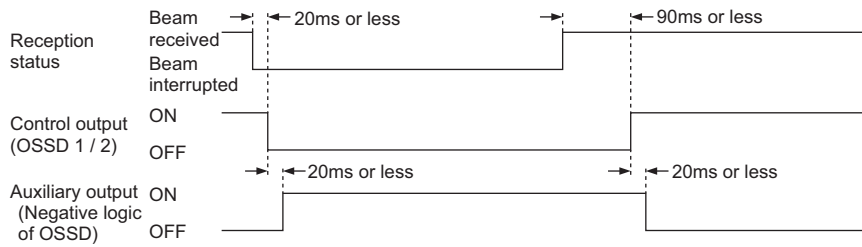
Time chart for manual reset*Time chart for auto-reset***3.5.3 Emission Amount Adjustment Function****DANGER!**

The emission amount adjuster of the ST4-A□V is used to reduce the beam emission of the ST4-A□V to prevent influencing other sensors.

Do not use the emission amount adjuster of the ST4-A□V to prevent the reflection off surfaces. If it is used for such purposes and the emission amount adjuster is set at MAX., the reflection off surfaces increases. This may disable the sensor from detecting objects, which could result in serious injury or death.

To cope with reflective surfaces, see "Influence of Reflective Surfaces" on page 20 .

This function is incorporated in the ST4-A□V. It is used to reduce the emission amount so that the emitted beam of ST4-A□V will not be received as extraneous light from the other sensors.

The emission amount can be reduced by turning the emission amount adjuster on the emitter of ST4-A□V to the MIN. side.

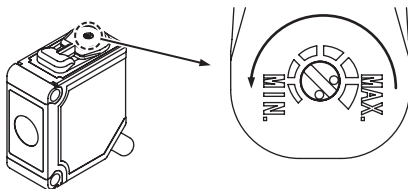

**DANGER!**

If you do not execute the following procedure, ST4-A□V cannot detect objects, which could result in serious injury or death.

**◆ Procedure**

1. Conduct safety checks at maximum emission to account for the effects of wall reflection.
2. Adjust the emission amount, respectively.
3. Make sure to conduct safety checks again.

**◆ NOTE**

The effective aperture angle $\pm 2.5^\circ$ does not vary even if the emission amount decreases. Before installing ST4-A□V, see "Influence of Reflective Surfaces" on page 20 .

3.6 Muting Function (Only for ST4-C12EX)

The muting function is incorporated only in the ST4-C12EX. To operate the muting function you need muting sensors (see page 60).

The muting function turns the safety function of ST4-C12EX off temporarily. When the control output OSSD 1/2 is ON, this function allows the work piece to pass through the sensing area without stopping the device.



DANGER!

Incorrect use of the muting function may cause accidents. Please study the muting function carefully before you use it.

Use the muting function while the machine cycle is not in danger mode. Maintain safety by using other measures while the muting control is activated.

For applications where the muting function is used when a work piece passes through, place the muting sensors at such a distance so that personnel do not accidentally activate the muting function.

Be sure to check that the muting function is working properly before you use it in live operation. Check the state of the muting lamp for cleanliness, brightness, etc.

Always connect a muting lamp and use the preset muting lamp diagnosis function (see page 74).

Install the muting lamp in a position where it can always be seen by operators who configure or adjust the machine.



◆ NOTE

The muting function complies with the requirements defined in the following international standards:

- ISO 13849-1 (EN 954-1/JIS B 9705-1): 'Safety of machinery - Safety-related parts of control systems - Part 1: General principles for design, Article 5.9 Muting'
- IEC 61496-1 (UL 61496/JIS B 9704-1): 'Safety of machinery - Electro sensitive protective equipment - Part 1: General requirements and tests' Annex A, A.7 Muting
- IEC 60204-1 (JIS B 9960-1): 'Safety of machinery - Electrical equipment of machines - Part 1: General requirements, 9.2.4 Overriding safeguards'
- EN 415-4: 'Safety of packaging machines part 4. Palletizers and depalletizers' Annex A, A2.2 Muting'
- ANSI B11.19-1990: 'for Machine Tools-Safeguarding When Referenced by the Other B11 Machine Tool Safety Standards-Performance Criteria for the Design, Construction, Care, and Operation' 4.2.3 Presence-Sensing Devices: Electro-Optical and Radio Frequency (R.F.)

- **ANSI/RIA R15.06-1999: 'for Industrial Robots and Robot Systems - Safety Requirements, 10.4.5 Muting'**

The muting function is active when all the conditions listed as follows are satisfied:

- The control output (OSSD 1/2) is ON.
- The incandescent lamp with 1 to 10W is connected to the muting lamp output.
- The muting inputs between S-A and S-B (between S-C and S-D, or between S-E and S-F) switch from OFF (open) to ON in a time range of 0 to 3 seconds.

However, if the time limit of 180sec is exceeded, the muting function will become inactive even if the preceding conditions are still satisfied.

3.6.1 What Is a Muting Sensor

As muting sensors you can use photoelectric sensors with a semiconductor output, inductive proximity sensors or position switches with NO (Normally Open) contacts.

The muting sensors have to turn on if an object is sensed. For NPN output this means 0V, for PNP output +V.



DANGER!

Only use a device that satisfies these criteria for muting sensors. If you use a device that does not meet these requirements, the muting function may operate with a different timing than expected, which could result in serious injury or death.

Always connect a muting lamp and use the preset muting lamp diagnosis function (see page 74).



◆ NOTE

The muting function can be used continuously even if the muting lamp diagnosis function (see page 74) is not active. However, if the muting lamp diagnosis function is not activated, perform the risk assessment by yourself according to the standards or regulations applicable for the respective region or country before using the muting function.

3.6.2 Installation of the Muting Sensor

In the following installation example, the muting sensors A and A' are PNP output type sensors. The muting sensors B and B' are NPN output type sensors.

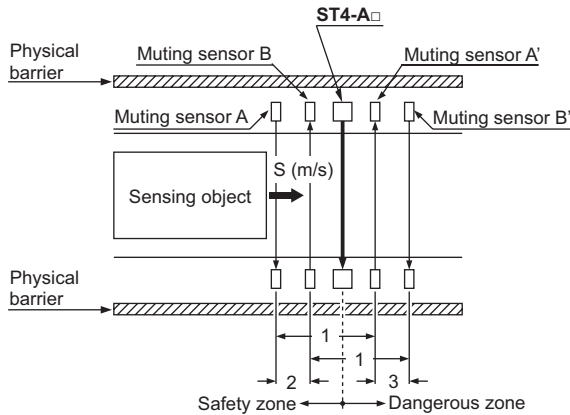

1. The distance between muting sensors A to A' and between B to B' must be shorter than the whole length of the object to be sensed.
2. The distance between muting sensors A and B has to be covered by the object to be sensed in less than 3 seconds. (S = speed)
Distance between A and B:
 $S \times 3$ (s)
3. The distance between muting sensors A' and B' has to be covered by the object to be sensed in less than 3 seconds.
Distance between A' and B':
 $S \times 3$ (s)

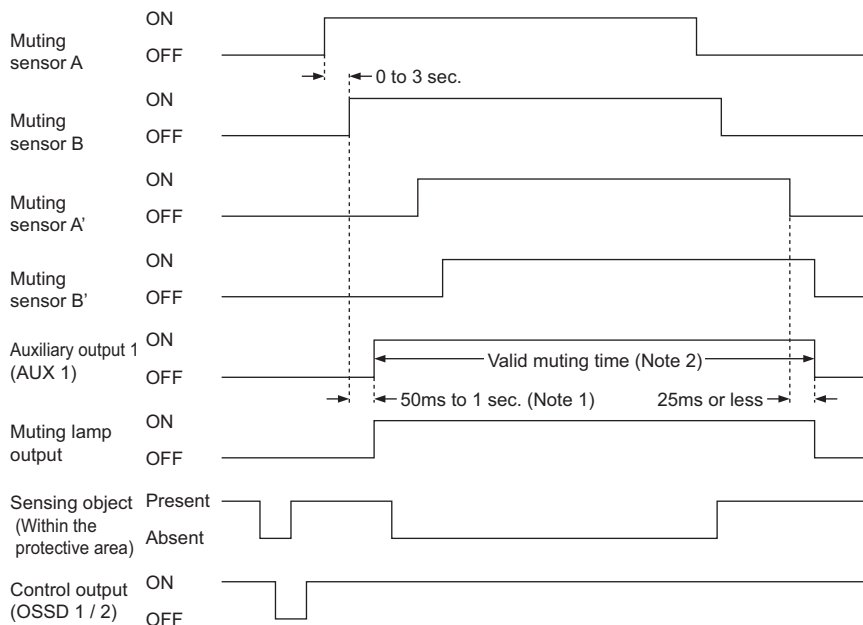

Time diagram for the muting function



◆ NOTE

1. When the diagnosis function for the muting lamp (see page 74) is active: If the muting lamp does not light up after 1s, the muting function is deactivated.
When diagnosis function for the muting lamp (see page 74) is not active: The muting function is activated with a delay of 50ms after the input conditions of the muting sensor A (A') and B (B') are satisfied.

- 2. The muting time can be set to 180 seconds or to have no time restriction (see page 67).**
- 3. We recommend connecting two muting lamps in parallel. Both together should not exceed 10W.**

3.7 Override Function (Only ST4-C12EX)

The override function is incorporated only in ST4-C12EX.

It forcibly turns off the safety function of ST4-C12EX. This function enables you to override the machine stop signal and to enter the muting state. It is used to restart the system smoothly without removing the objects from the production line when the sequence of operations is incorrect or in case of a power loss.

The override function is used when the muting function is active, something happened which stopped the operation and the operation then needs to be restarted again with the control output (OSSD 1/2) in OFF status.



DANGER!

Incorrect use of the muting function may cause accidents. Please study the muting function carefully before you use it.

Use the muting function while the machine cycle is not in danger mode. Maintain safety by using other measures while the muting control is activated.

For applications where the muting function is used when a work piece passes through, place the muting sensors at such a distance so that personnel do not accidentally activate the muting function.

Be sure to check that the muting function is working properly before you use it in live operation. Check the state of the muting lamp for cleanliness, brightness, etc.

Always connect a muting lamp and use the preset muting lamp diagnosis function (see page 74).

Install the muting lamp in a position where it can always be seen by operators who configure or adjust the machine.

When the override function of ST4-C12EX is active, the sensing area of the ST4-A□ can be intruded. If multiple sensing areas exist, make sure to install muting lamps in each sensing area. For all the sensing areas there must be a signal to prevent operators from entering into it. Failure to do so may allow operators to enter into the sensing areas, which could result in serious injury or death.



◆ NOTE

The muting function complies with the requirements defined in the following international standards:

- ISO 13849-1 (EN 954-1/JIS B 9705-1): 'Safety of machinery - Safety-related parts of control systems - Part 1: General principles for design, Article 5.9 Muting'

- **IEC 61496-1 (UL 61496/JIS B 9704-1): 'Safety of machinery - Electro sensitive protective equipment - Part 1: General requirements and tests' Annex A, A.7 Muting**
- **IEC 60204-1 (JIS B 9960-1): 'Safety of machinery - Electrical equipment of machines - Part 1: General requirements, 9.2.4 Overriding safeguards'**
- **EN 415-4: 'Safety of packaging machines part 4. Palletizers and depalletizers' Annex A, A2.2 Muting'**
- **ANSI B11.19-1990: 'for Machine Tools-Safeguarding When Referenced by the Other B11 Machine Tool Safety Standards-Performance Criteria for the Design, Construction, Care, and Operation' 4.2.3 Presence-Sensing Devices: Electro-Optical and Radio Frequency (R.F.)**
- **ANSI/RIA R15.06-1999: 'for Industrial Robots and Robot Systems - Safety Requirements, 10.4.5 Muting'**

The override function is active when all the conditions listed as follows are satisfied:

- The incandescent lamp with 1 to 10W is connected to the muting lamp output.
- The override signal is input from either or both of the muting inputs between S-A and S-B (between S-C and S-D, or S-E and S-F)
- Both the emission halt input shall be opened and the override input shall be short-circuited within 1 second (3 sec. continuously).

If any of these three conditions is not satisfied or takes longer than the valid muting/override time of 60 or 600 seconds, the override function becomes inactive (see "Muting Pattern Selection Function (Only ST4-C12EX)" on page 67).



◆ NOTE

The muting function can be used continuously even if the muting lamp diagnosis function (see page 74) is not active. However, if the muting lamp diagnosis function is not activated, perform the risk assessment by yourself according to the standards or regulations applicable for the respective region or country before using the muting function.

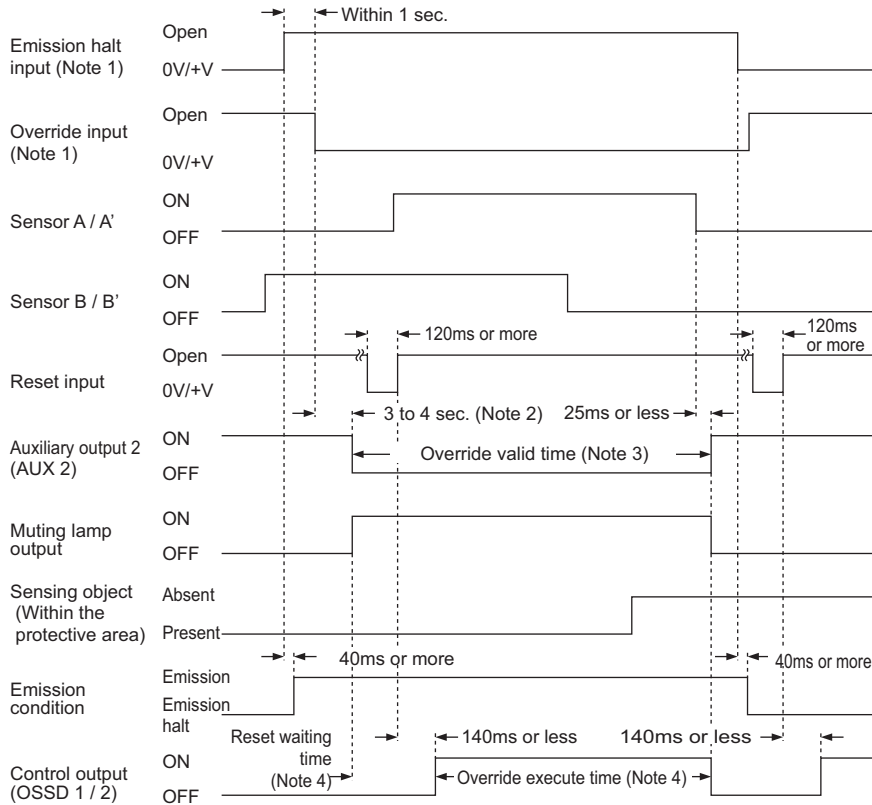

Time chart for manual reset



◆ NOTE

- 1. The order in which the emission halt input is opened and the override input is short-circuited is not important.**
- 2. This behavior is true when the muting lamp diagnosis function is active. If the muting lamp does not light up after 4 seconds, the override function will be deactivated. When the muting lamp diagnosis function is not active, the muting function becomes active 3 seconds after the input conditions of the muting sensor A (A') and B (B') are satisfied. For the setting of the muting lamp diagnosis function, refer to Muting Lamp Diagnosis Function (see page 74).**
- 3. Override time can be set to either 60 or 600 seconds. For the setting, refer to Muting Pattern Selection Function (see page 67).**

4. The total time of the reset waiting time and the override execute time is the override valid time. The override function will not be performed until the reset waiting time is passed and the override conditions are met.

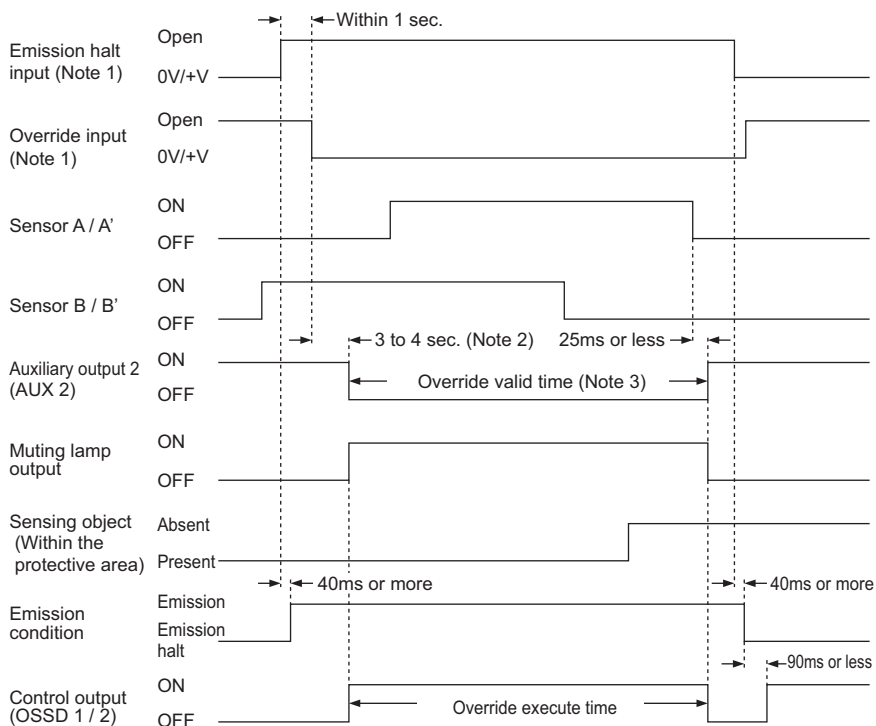

Time chart for auto-reset



◆ NOTE

1. The order in which the emission halt input is opened and the override input is short-circuited is not important.
2. This behavior is true when the muting lamp diagnosis function is active. If the muting lamp does not light up after 4 seconds, the override function will be deactivated. When the muting lamp diagnosis function is not active, the muting function becomes active 3 seconds after the input conditions of the muting sensor A (A') and B (B') are satisfied. For the setting of the muting lamp diagnosis function, refer to Muting Lamp Diagnosis Function (see page 74).
3. Override time can be set to either 60 or 600 seconds. For the setting, refer to Muting Pattern Selection Function (see page 67).

3.8 Muting Pattern Selection Function (Only ST4-C12EX)

The muting pattern selection function is incorporated only in ST4-C12EX.

The ST4-C12EX presets the muting patterns complying with ISO 12643 (Safety requirements for graphic technology equipment and systems).

The muting pattern and the valid time of the muting/override can be set with the setting switches "SW 1 to 4."



◆ CAUTION

Make sure to turn off the power to set the muting pattern. If you set the muting pattern while power is on, it will be invalid.

Muting pattern no.	Valid time			
	Muting	Override	Muting	Override
	180s	60s	No time restriction	600s
1	SW1 <input type="checkbox"/> ON SW2 <input type="checkbox"/> ON SW3 <input type="checkbox"/> ON SW4 <input type="checkbox"/> ON SW5 <input type="checkbox"/> ON SW6 <input type="checkbox"/> ON SW7 <input type="checkbox"/> ON SW8 <input type="checkbox"/> ON	SW1 <input type="checkbox"/> ON SW2 <input type="checkbox"/> ON SW3 <input type="checkbox"/> ON SW4 <input type="checkbox"/> ON SW5 <input type="checkbox"/> ON SW6 <input type="checkbox"/> ON SW7 <input type="checkbox"/> ON SW8 <input type="checkbox"/> ON	SW1 <input type="checkbox"/> ON SW2 <input type="checkbox"/> ON SW3 <input type="checkbox"/> ON SW4 <input type="checkbox"/> ON SW5 <input type="checkbox"/> ON SW6 <input type="checkbox"/> ON SW7 <input type="checkbox"/> ON SW8 <input type="checkbox"/> ON	SW1 <input type="checkbox"/> ON SW2 <input type="checkbox"/> ON SW3 <input type="checkbox"/> ON SW4 <input type="checkbox"/> ON SW5 <input type="checkbox"/> ON SW6 <input type="checkbox"/> ON SW7 <input type="checkbox"/> ON SW8 <input type="checkbox"/> ON
2	SW1 <input type="checkbox"/> ON SW2 <input type="checkbox"/> ON SW3 <input type="checkbox"/> ON SW4 <input type="checkbox"/> ON SW5 <input type="checkbox"/> ON SW6 <input type="checkbox"/> ON SW7 <input type="checkbox"/> ON SW8 <input type="checkbox"/> ON	SW1 <input type="checkbox"/> ON SW2 <input type="checkbox"/> ON SW3 <input type="checkbox"/> ON SW4 <input type="checkbox"/> ON SW5 <input type="checkbox"/> ON SW6 <input type="checkbox"/> ON SW7 <input type="checkbox"/> ON SW8 <input type="checkbox"/> ON	SW1 <input type="checkbox"/> ON SW2 <input type="checkbox"/> ON SW3 <input type="checkbox"/> ON SW4 <input type="checkbox"/> ON SW5 <input type="checkbox"/> ON SW6 <input type="checkbox"/> ON SW7 <input type="checkbox"/> ON SW8 <input type="checkbox"/> ON	SW1 <input type="checkbox"/> ON SW2 <input type="checkbox"/> ON SW3 <input type="checkbox"/> ON SW4 <input type="checkbox"/> ON SW5 <input type="checkbox"/> ON SW6 <input type="checkbox"/> ON SW7 <input type="checkbox"/> ON SW8 <input type="checkbox"/> ON
3	SW1 <input type="checkbox"/> ON SW2 <input type="checkbox"/> ON SW3 <input type="checkbox"/> ON SW4 <input type="checkbox"/> ON SW5 <input type="checkbox"/> ON SW6 <input type="checkbox"/> ON SW7 <input type="checkbox"/> ON SW8 <input type="checkbox"/> ON	SW1 <input type="checkbox"/> ON SW2 <input type="checkbox"/> ON SW3 <input type="checkbox"/> ON SW4 <input type="checkbox"/> ON SW5 <input type="checkbox"/> ON SW6 <input type="checkbox"/> ON SW7 <input type="checkbox"/> ON SW8 <input type="checkbox"/> ON	SW1 <input type="checkbox"/> ON SW2 <input type="checkbox"/> ON SW3 <input type="checkbox"/> ON SW4 <input type="checkbox"/> ON SW5 <input type="checkbox"/> ON SW6 <input type="checkbox"/> ON SW7 <input type="checkbox"/> ON SW8 <input type="checkbox"/> ON	SW1 <input type="checkbox"/> ON SW2 <input type="checkbox"/> ON SW3 <input type="checkbox"/> ON SW4 <input type="checkbox"/> ON SW5 <input type="checkbox"/> ON SW6 <input type="checkbox"/> ON SW7 <input type="checkbox"/> ON SW8 <input type="checkbox"/> ON











◆ NOTE

If other settings than the preceding muting patterns are chosen, the device will switch into lockout state, and an error will be indicated on the fault display (red).

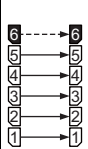
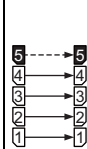
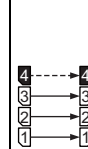
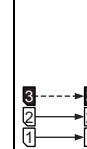
3.8.1 Control Condition of Muting Pattern No. 1

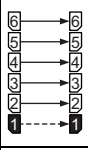
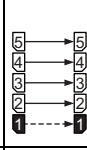
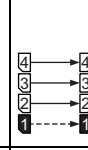
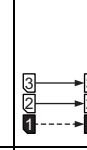
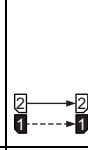
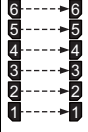
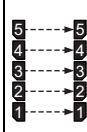
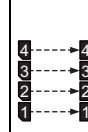
If you use muting pattern no. 1 together with different sets of ST4-A□, you can choose whether the muting state is active for the top-most, bottom-most or all sensor heads. To select one of these three options, you have to connect the muting input terminals as described in the following table.

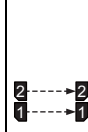
Symbols:  = addresses,  = muting conditions

Muting input terminals	Number of connected ST4-A□s					
	6 sets	5 sets	4 sets	3 sets	2 sets	1 set
Short-circuit: S-A to S+ S-B to S-						n/a
Short-circuit: S-C to S+ S-D to S-						n/a
Short-circuit: S-E to S+ S-F to S-						



◆ EXAMPLE

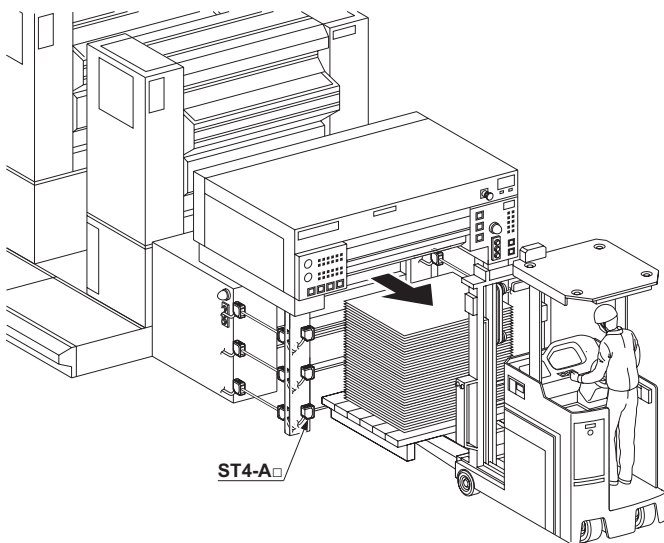

3.8.2 Control Condition of Muting Pattern No. 2

If you use muting pattern no. 2 together with different sets of ST4-A□, you can choose whether the muting state is active for the top-most, for all others except the top-most, or for all sensor heads. To select one of these three options, you have to connect the muting input terminals as described in the following table.

Symbols: $\overset{2}{\square}$ = addresses, $\overset{6}{\square} \dashrightarrow \overset{5}{\square}$ = muting conditions

Muting input terminals	Number of connected ST4-A□s					
	6 sets	5 sets	4 sets	3 sets	2 sets	1 set
Short-circuit: S-A to S+ S-B to S-						n/a
Short-circuit: S-C to S+ S-D to S-						n/a
Short-circuit: S-E to S+ S-F to S-						



◆ EXAMPLE

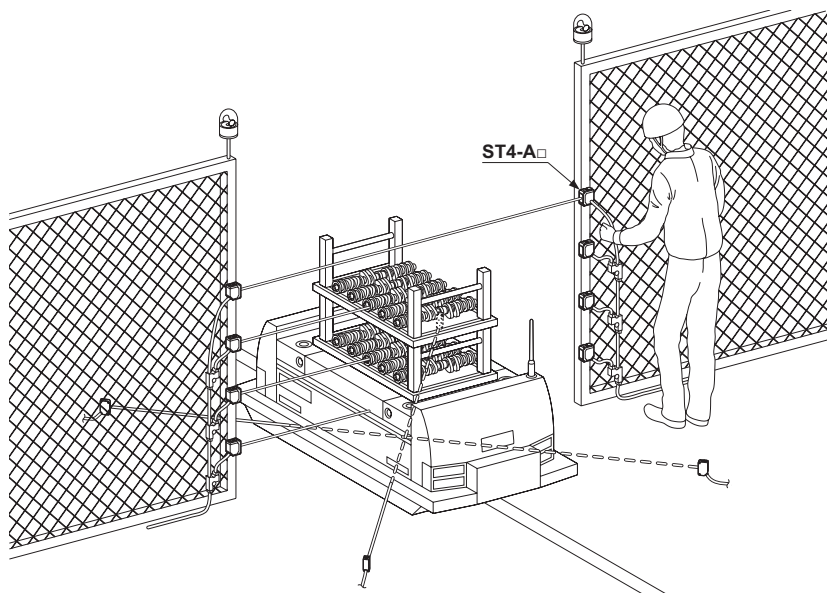

3.8.3 Control Condition of Muting Pattern No. 3

If you use muting pattern no. 3 together with different sets of ST4-A□, you can choose whether the muting state is active for the sensor heads indicated in black in the following table. To select one of these three options, you have to connect the muting input terminals as described in the following table.

Symbols: = addresses, = muting conditions

Muting input terminals	Number of connected ST4-A□s					
	6 sets	5 sets	4 sets	3 sets	2 sets	1 set
Short-circuit: S-A to S+ S-B to S-						n/a
Short-circuit: S-C to S+ S-D to S-						n/a
Short-circuit: S-E to S+ S-F to S-						



◆ EXAMPLE

4 sets of ST4-A□ are controlled by ST4-C12EX.

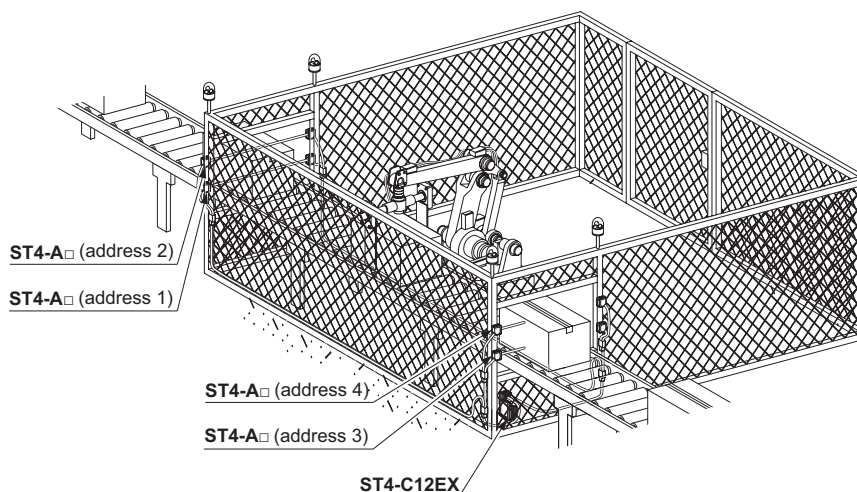

3.9 Sensor Diagnosis Function (Only ST4-C12EX)



The sensor diagnosis function is incorporated only in the controller ST4-C12EX. The function checks the reception status "beam received" and "beam interrupted" of the connected ST4-A□ as well as any other sensor fault.

If ST4-A□ is in the status "beam received", the muting input indicator (orange) lights up. However, if ST4-A□ is in the status "beam interrupted" or ST4-A□ is not connected, the muting input indicator (orange) stays off.

Under normal operation the display shows the state of the muting input terminals S-A to S-F.

If the sensor diagnosis function is active, the display also shows the state of the sensor heads (ST4-A□).

The relation between the muting input indicator (orange) and the addresses of the sensor heads (ST4-A□) is as follows.

	Normal operation	Active sensor diagnosis function
Setting switch "SW 5"		
Muting input indicator (Orange)	S-A <input type="radio"/> <input type="radio"/> S-B S-C <input type="radio"/> <input type="radio"/> S-D S-E <input type="radio"/> <input type="radio"/> S-F	Address 4 (S-A) <input type="radio"/> <input type="radio"/> Address 1 (S-B) Address 5 (S-C) <input type="radio"/> <input type="radio"/> Address 2 (S-D) Address 6 (S-E) <input type="radio"/> <input type="radio"/> Address 3 (S-F)

Continuous diagnosis under normal operation

While the power is on, you have to set the setting switch "SW5" to ON to activate the diagnosis function for ST4-A□.

If under normal operation a power loss occurs, power is supplied when the setting switch "SW5" is ON, the control output (OSSD 1/2) switches to OFF, and "ε" is indicated on the fault display (red).

To reset the system, you have to turn OFF the power and the setting switch "SW5". Then set the power and "SW5" to ON so that the sensor can return to the normal operation.



◆ EXAMPLE

Four units of ST4-A□ (address 1 to 4) are connected and only the muting input indicators (orange) of the addresses 1, 3, and 4 light up:

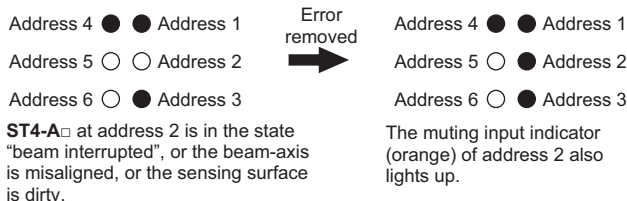

Temporary diagnosis in case of lockout

If an unknown error occurs while the sensor is in the lockout state, the error is indicated on the fault display (red). You then can use the diagnosis function temporarily to find out where the error occurred.



◆ Procedure

1. In case of lockout, turn off the power.
2. Turn ON the setting switch "SW5".
3. Turn on the power again.

The control output (OSSD 1/2) switches to OFF and "ε" is indicated on the fault display (red) to conduct the diagnosis of ST4-A□.

After turning OFF the power, eliminate the error and set "SW5" to OFF. When turning on the power again, the behavior of the sensor returns to normal operation and the diagnosis function has been activated only temporarily to find the error (see "Troubleshooting" on page 79).



◆ CAUTION

Turn off the power in order to eliminate the error display.



◆ EXAMPLE

Six units of ST4-A□ (addresses 1 to 6) are connected and only the muting input indicators (orange) of addresses 1 and 2 light up

Address 4 ○ ● Address 1
Address 5 ○ ● Address 2
Address 6 ○ ○ Address 3

The cable between addresses 2 and 3 may be disconnected, or **ST4-A**□ at address 3 may be broken.

Error removed
➔

Address 4 ● ● Address 1
Address 5 ● ● Address 2
Address 6 ● ● Address 3

The muting input indicators (orange) of addresses 3 to 6 also light up.

3.10 Muting Lamp Diagnosis Function (Only ST4-C12EX)

The diagnosis function of the muting lamp is incorporated only in the controller ST4-C12EX.

This function checks the status of the muting lamp while muting is in progress. If the lamp is blown, the auxiliary output 3 (AUX 3) turns off. Furthermore, the muting status is cancelled immediately if the lamp is blown.

It is possible to nullify the muting lamp diagnosis function.



WARNING!

If the muting lamp diagnosis function is not active, you have to execute the risk assessment by yourself.



CAUTION

Make sure to turn off the power in order to set the muting lamp diagnosis function.

	Muting lamp diagnosis function	
	Active	Inactive
Setting switch "SW8"	SW1 <input type="checkbox"/> SW2 <input type="checkbox"/> SW3 <input type="checkbox"/> SW4 <input type="checkbox"/> SW5 <input type="checkbox"/> SW6 <input type="checkbox"/> SW7 <input type="checkbox"/> SW8 <input checked="" type="checkbox"/>	SW1 <input type="checkbox"/> SW2 <input type="checkbox"/> SW3 <input type="checkbox"/> SW4 <input type="checkbox"/> SW5 <input type="checkbox"/> SW6 <input type="checkbox"/> SW7 <input type="checkbox"/> SW8 <input type="checkbox"/>



Procedure

1. The muting lamp diagnosis function is activated by default.
2. To deactivate the muting lamp diagnosis function, turn the power off once.
3. Set the DIP switch "SW8" to ON.
4. Turn on the power.

Chapter 4

Maintenance

4.1 Daily Inspection

If an error (see "Troubleshooting" on page 79) occurs, report this to the maintenance staff in charge. If the problem cannot be solved, please contact our office.

Please make a copy of this checklist, check each inspection item in the respective square, and file the list for your records.



DANGER!

Be sure to inspect the following items prior to operation and confirm that there is no error. Operating this device without inspection or in an error condition can result in serious injury or death.

Check list (Daily inspection)

Check column	Inspection item
<input type="checkbox"/>	Dangerous parts of the machine cannot be reached without passing through the sensing area of this device.
<input type="checkbox"/>	Some part of operator's body remain in the sensing area when operation is done with dangerous parts of the machine.
<input type="checkbox"/>	The calculated safety distance has been maintained or exceeded during installation.
<input type="checkbox"/>	There is no damage to the safety guard or protective structure.
<input type="checkbox"/>	There is no defect or damage in the wiring.
<input type="checkbox"/>	The corresponding connectors have been connected securely.
<input type="checkbox"/>	No dirt or scratches exist on the sensing surface.
<input type="checkbox"/>	The fault indicator (yellow) of ST4-C11 or the fault display (red) of ST4-C12EX are off.
<input type="checkbox"/>	The beam interruption indicators (red) on the emitter and receiver of ST4-A□ are off, and the beam emission indicator (green) on the emitter of ST4-A□ as well as the stable incident beam indicator (green) on the receiver of ST4-A□ light up when no object is present in the sensing area. The control output (OSSD 1/2) is ON. At this time, the effect of external noise can be inspected. If external noise effects operation, eliminate the cause and test again for noise.
<input type="checkbox"/>	With the machine in the operating condition, the dangerous parts operate normally when no object is present in the sensing area.
<input type="checkbox"/>	The dangerous parts stop immediately when the power supply of the sensor is turned OFF.
<input type="checkbox"/>	The control output (OSSD 1/2) turns OFF when the emission halt input terminal (between T1 and T2) of the controller is open. At this time, the effect of external noise can be inspected. If external noise effects operation, eliminate the cause and test again for noise.
<input type="checkbox"/>	Be sure to check the operation of the muting function before using it. Furthermore, check the condition of the muting lamp (cleanliness, brightness, etc.).

4.2 Periodic Inspection Checklist (Every Six Months)



DANGER!

Be sure to inspect the following items every six months and confirm that there is no error. Operating this device without inspection or in an error condition can result in serious injury or death.

Check column	Inspection item
<input type="checkbox"/>	The structure of the machine does not obstruct any of the safety mechanisms designed for stopping the operation.
<input type="checkbox"/>	No modification has been made in the machine controls which obstructs the safety mechanisms.
<input type="checkbox"/>	The output of this device is detected correctly.
<input type="checkbox"/>	The wiring from this device is correct.
<input type="checkbox"/>	The overall response time of the complete machine is equal to or less than the calculated value.
<input type="checkbox"/>	The actual number of operation cycles (time) of the limited lifetime parts (relay, etc.) is less than their rated operation cycles (time).
<input type="checkbox"/>	No screws or connectors of this device are loose.
<input type="checkbox"/>	No extraneous light source or reflective object has been added near this device.

4.3 Inspection After Maintenance

Under the following circumstances, perform all the inspection items mentioned in Daily Inspection List (see page 76) and Periodic Inspection List (see page 77).

1. When any part of this device needs to be replaced.
2. When abnormalities occur during operation.
3. When you perform beam-axis alignment of the emitter and receiver.
4. When the installation place or environment of this device is changed.
5. When the wiring method or wiring layout is changed.
6. When FSD (Final Switching Device) parts are replaced.
7. When FSD (Final Switching Device) settings are changed.

Chapter 5

Troubleshooting

5.1 Troubleshooting of Controller ST4-C11

First of all, check the wiring, the power supply voltage and the power supply capacity.

The number of blinks of the fault indicator (yellow) on ST4-C11 varies depending on the condition of error as shown in the following table.

Symptom	Cause		Remedy
All indicators are OFF.	Power is not being supplied.		Check that the power supply capacity is sufficient. Connect the power supply correctly.
	Supply voltage is out of the specified range.		Set the supply voltage to 24V DC ⁺¹⁰ -%.
Emission halt input indicator (orange) lights up.	The controller is in the emission halt condition.		Check that the emission halt input terminals (between T1 and T2) short-circuit.
Interlock indicator (yellow) lights up.	Reset condition is not cancelled.	Reset input terminal is not wired.	Wire the reset input terminals correctly (manual reset: between X1 and X2, or auto reset: between X1 and X3). To ensure the safety of the system, use the NC contact of a forcibly guided relay.
		Relay is welded.	Replace the relay.
		Relay response time is slow.	Replace the relay with proper response time.
		Reset signal at start-up is not input. (manually)	Use a momentary switch. Replace the switch.
Fault indicator lights up Microcomputer error	Large noise		Check the noise condition around this device.
	Internal error		Replace the ST4-C11.
Fault indicator blinks once • Error between emitter and receiver of ST4-A□	The emitters and receivers are of different types.		Use the same type of emitter and receiver. Do not mix them.
	Series connection condition is out of the specified range.		Set the series connection condition within the specified range (see "Connecting Multiple Sensors Heads" on page 23).
	The serial signal short-circuits.		Check that the cable of ST4-A□, ST4-CCJ□ (optional) or ST4-CCJ05-WY (optional) is not disconnected and the connectors are not loose.
	The connected ST4-A□ is faulty.		Check the indicator of the connected ST4-A□ (see "Connecting Multiple Sensors Heads" on page 23).

Symptom	Cause	Remedy
Fault indicator blinks twice <ul style="list-style-type: none"> Control output (OSSD 1/2) error 1 	Control output (OSSD 1/2) short-circuits with other I/O wires, or the control output (OSSD 1/2) short-circuits with other control output (OSSD 1/2)	Wire the control output (OSSD 1/2) wires correctly (see page 36).
	Control output (OSSD 1/2) short-circuits with +V or 0V.	
	The PNP/NPN settings of the output polarity selection switch and the control output (OSSD 1/2) do not match.	Check the output polarity selection switch.
	Output circuit error.	Output circuit is damaged. Replace the ST4-C11.
Fault indicator blinks three times <ul style="list-style-type: none"> Control output (OSSD 1/2) error 2 	Excessive incoming current flows in the control output (OSSD 1/2).	Current value should be within the specified control output (OSSD 1/2). For details, see "Specifications, Controller ST4-C12EX" on page 90.
	Control output (OSSD 1/2) short-circuits with +V or 0V.	Wire the control output (OSSD 1/2) wires correctly (see page 36).
	The PNP/NPN settings of the output polarity selection switch and the control output (OSSD 1/2) do not match.	Check the output polarity selection switch. Wire the control output (OSSD 1/2) wires correctly (see page 36).
	Output circuit error.	Output circuit is damaged. Replace the ST4-C11.
Fault indicator blinks four times <ul style="list-style-type: none"> Extraneous light error 	Extraneous light is entering or light from other ST4-A□ is entering.	When the power is ON, prevent any extraneous light from entering the receiver. If the extraneous light is coming from ST4-A□, execute the interference prevention function see "Interference Prevention Function" on page 54. In case of ST4-A□V, execute the emission amount adjustment function (see page 57) as well. If the error could not be resolved, contact our office.
Fault indicator blinks seven times <ul style="list-style-type: none"> Reset error 	Voltage level of reset input signal is unstable.	Wire the reset input terminals correctly (manual reset: between X1 and X2, or auto reset: between X1 and X3).
Fault indicator blinks eight times <ul style="list-style-type: none"> Input voltage monitor error 	Supply voltage is out of the specified range.	Set the supply voltage to 24V DC ⁻¹⁰ / ₊₁₅ %.
	Internal reference voltage error.	Check the power supply capacity.

Symptom	Cause		Remedy
Fault indicator blinks nine times <ul style="list-style-type: none"> Switch setting error 	Output polarity selection switch (PNP/NPN setting)	Output polarity was changed during operation of the device.	Turn OFF the power of the device and change the output polarity.
		Switch is broken.	Replace the ST4-C11.
Fault indicator blinks ten times or more <ul style="list-style-type: none"> Effect from noise/power supply or failure of internal circuit 	Affected by noise or power supply. Internal circuit is damaged.		Check the noise condition around this device. Check the wiring, supply voltage, and power supply capacity. If the error is not resolved, contact our office.
Control output indicator (green) does not light up.	The beam axes are not correctly aligned.		Align the beam axes. When connecting sensors in series, match the sensor addresses between emitter and receiver of ST4-A□.
	The receiver of ST4-A□ is wrongly connected to the emitter connector of the controller, and the emitter of ST4-A□ is wrongly connected to the receiver connector of the controller.		Make sure that the colors of the connectors match: gray: emitter, black: receiver.
	Mixed connection of emitter and receiver for series connection.		
	The connected ST4-A□ is faulty.		Check the indicator of the connected ST4-A□ (see "Connecting Multiple Sensors Heads" on page 23). For details, see "Troubleshooting of the Sensor ST4-A□" on page 86.

If the device does not work normally after checking the items in the preceding table, contact our office.

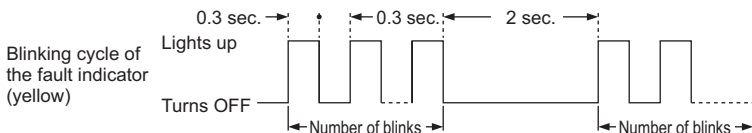

The blinking interval of the fault indicator (yellow) is shown in the following figure. There is approx. 2 seconds between blinking cycles.



5.2 Troubleshooting of Controller ST4-C12EX

First of all, check the wiring, the power supply voltage and the power supply capacity.

The display of the fault display (red) on ST4-C12EX varies depending on the condition of the error as shown in the following table.

Symptom	Cause		Remedy
All indicators are OFF.	Power is not being supplied.		Check that the power supply capacity is sufficient. Connect the power supply correctly.
	Supply voltage is out of the specified range.		Set the supply voltage to 24V DC ⁺¹⁰ ₋₁₅ %.
Emission halt input indicator (orange) lights up.	The controller is in the emission halt condition.		Check that the emission halt input terminals (between T1 and T2) short-circuit.
Interlock indicator (yellow) lights up.	Reset condition is not cancelled.	Reset input terminal is not wired.	Wire the reset input terminals correctly (manual reset: between X1 and X2, or auto reset: between X1 and X3). To ensure the safety of the system, use the NC contact of a forcibly guided relay.
		Relay is welded.	Replace the relay.
		Relay response time is slow.	Replace the relay with proper response time.
		Reset signal at start-up is not input. (manually)	Use a momentary switch. Replace the switch.
Fault display:  • Setting data error	Large noise		Check the noise condition around this device.
	Internal error		Replace the ST4-C12EX.
Fault display:  • System between emitter and receiver on ST4-A□ error	The emitters and receivers are of different types.		Use the same type of emitter and receiver. Do not mix them.
	Series connection condition is out of the specified range.		Set the series connection condition within the specified range (see "Connecting Multiple Sensors Heads" on page 23).
	The serial signal short-circuits.		Check that the cable of ST4-A□, ST4-CCJ□ (optional) or ST4-CCJ05-WY (optional) is not disconnected and the connectors are not loose.
	The connected ST4-A□ is faulty.		Perform the sensor diagnosis function (see page 71). Check the indicator of the connected ST4-A□ (see "Connecting Multiple Sensors Heads" on page 23). For details, see "Troubleshooting of the Sensor ST4-A□" on page 86.
Fault display:  • Control output (OSSD 1/2) error	Control output (OSSD 1/2) short-circuits with other I/O wires, or the control output (OSSD 1/2) short-circuits with other control output (OSSD 1/2).		Wire the control output (OSSD 1/2) wires correctly (see page 36).

Symptom	Cause		Remedy
1	Control output (OSSD 1/2) short-circuits with +V or 0V.		
	The PNP/NPN settings of the output polarity selection switch and the control output (OSSD 1/2) do not match.		Check the output polarity selection switch. Wire the control output (OSSD 1/2) wires correctly (see page 36).
	Output circuit error.		Output circuit is damaged. Replace the ST4-C12EX.
Fault display: 3 <ul style="list-style-type: none"> Control output (OSSD 1/2) error 2 	Excessive incoming current flows in the control output (OSSD 1/2).		Current value should be within the specified control output (OSSD 1/2). For details, see "Specifications, Controller ST4-C12EX" on page 90.
	Control output (OSSD 1/2) short-circuits with +V or 0V.		Wire the control output (OSSD 1/2) wires correctly (see page 36).For details, refer to Wiring (see page 36).
	The PNP/NPN settings of the output polarity selection switch and the control output (OSSD 1/2) do not match.		Check the output polarity selection switch. Wire the control output (OSSD 1/2) wires correctly (see page 36).
	Output circuit error.		Output circuit is damaged. Replace the ST4-C12EX.
Fault display: 4 <ul style="list-style-type: none"> Extraneous light error 	Extraneous light is entering or light from other ST4-A□ is entering.		When the power is ON, prevent any extraneous light from entering the receiver. If the extraneous light is coming from ST4-A□, execute the interference prevention function see "Interference Prevention Function" on page 54. In case of ST4-A□V, execute the emission amount adjustment function (see page 57) as well. If the error could not be resolved, contact our office.
Fault display: 5 <ul style="list-style-type: none"> Muting lamp error 	Muting lamp terminals short-circuit.		Wire the muting lamp correctly (see page 36).
	Muting lamp output short-circuits with other I/O wires.		
	Excessive incoming current flows in the muting output.		Current value should be within the specification of muting lamp. For details, see "Specifications, Controller ST4-C12EX" on page 90.
	Output circuit error.		Output circuit is damaged. Replace the ST4-C12EX.
Fault display: 7 <ul style="list-style-type: none"> Reset error 	Voltage level of reset input signal is unstable.		Wire the reset input terminals correctly (manual reset: between X1 and X2, or auto reset: between X1 and X3).
Fault display: 9 <ul style="list-style-type: none"> Switch setting error 	Output polarity selection switch (PNP/NPN setting)	Output polarity was changed during operation of the device.	Turn OFF the power of the device and change the output polarity.
		Switch is broken.	

Symptom	Cause		Remedy
	Setting switch	Various settings were changed during operation of the device.	Turn OFF the power of the device and change the output polarity.
		Switch is broken.	Replace the ST4-C12EX.
Fault display: ϵ <ul style="list-style-type: none"> During sensor diagnosis function (see page 71) 	The control output (OSSD 1/2) remains OFF and making a diagnosis of the beam received/interrupted condition of the sensor.		After turning OFF the power of device, turn OFF the setting switch "SW5" to return to normal operation.
Fault display: F <ul style="list-style-type: none"> Effect from noise/power supply or failure of internal circuit 	Affected by noise or power supply. Internal circuit is damaged.		Check the noise condition around this device. If the error could not be resolved, contact our office.
Control output indicator (green) does not light up.	The beam axes are not correctly aligned.		Align the beam axes. When connecting sensors in series, match the sensor addresses between emitter and receiver of ST4-A□.
	The receiver of ST4-A□ is wrongly connected to the emitter connector of the controller, and the emitter of ST4-A□ is wrongly connected to the receiver connector of the controller.		Make sure that the colors of the connectors match: gray: emitter, black: receiver.
	Mixed connection of emitter and receiver for series connection.		
	The connected ST4-A□ is faulty.		Perform the sensor diagnosis function (see page 71). Check the indicator of the connected ST4-A□ (see "Connecting Multiple Sensors Heads" on page 23). For details, see "Troubleshooting of the Sensor ST4-A□" on page 86.

5.3 Troubleshooting of the Sensor ST4-A□

Emitter-related problems

Symptom	Cause	Remedy
All indicators are OFF.	Failure of cable connection.	Make sure that the connector is not loose. In case of series connection, find the disconnected part (the one for which the sensor's indicator lights up).
The beam interruption indicator (red) and the stable incident beam indicator (green) light up simultaneously.	The beam axes are not correctly aligned.	Align the beam axes. Normal operation is indicated when the sensor receives the light beam and the interruption indicator (red) turns OFF.
	The emitter is connected to another emitter.	Check if the emitter is connected to the receiver side. Make sure that the colors of the connectors match: gray: emitter, black: receiver.
The beam interruption indicator (red) lights up.	The sensor is in the emission halt condition.	Check that the emission halt input terminals (between T1 and T2) of the controller are short-circuited.
	The sensor is damaged.	Replace the emitter of ST4-A□.

Receiver-related problems

Symptom	Cause	Remedy
All indicators are OFF.	Failure of cable connection.	Make sure that the connector is not loose. In case of series connection, find the disconnected part (the one for which the sensor's indicator lights up).
	The sensor is in an unstable incident beam condition.	Align the beam axes. Normal operation is indicated when the stable incident beam indicator (green) lights up.
The beam interruption indicator (red) and the stable incident beam indicator (green) light up simultaneously.	The receiver of ST4-A□ is wrongly connected to the emitter connector of the controller, and the emitter of ST4-A□ is wrongly connected to the receiver connector of the controller.	Make sure that the colors of the connectors match: gray: emitter, black: receiver.
	Mixed connection of emitter and receiver at series connection.	
	The sensor is damaged.	
The beam interruption indicator (red) lights up.	The beam axes are not correctly aligned.	Align the beam axes. Normal operation is indicated when the interruption indicator (red) turns OFF and the stable incident beam indicator (green) lights up.
	The receiver is connected to another receiver.	Check if the receiver is connected to the emitter side. Make sure that the colors of the connectors match: gray: emitter, black: receiver.

Chapter 6

Specifications

6.1 Specifications, Controller ST4-C11

Item	Description				
Supply voltage	24V DC ^{±10%} % Ripple P-P 10% or less				
Current consumption	0.1A or less				
Control output OSSD1/2 (Note 1)	PNP or NPN open-collector transistor. Select PNP or NPN output with switch.				
	<table border="1"> <tr> <td>PNP output</td> <td> <ul style="list-style-type: none"> Max. source current: 200mA Applied voltage: same as the supply voltage (between control output and +V) Residual voltage: 2.5V or less (at 200mA source current) Leakage current: 200μA or less (also in power OFF state) Maximum load capacity: 1μF (with or without load) Load wiring resistance: 3Ω or less </td> </tr> <tr> <td>NPN output</td> <td> <ul style="list-style-type: none"> Max. 200mA sink current Applied voltage: same as the supply voltage (between control output and 0V) Residual voltage: 2.0V or less (at 200mA sink current) Leakage current: 200μA or less (also in power OFF state) Maximum load capacity: 1μF (with or without load) Load wiring resistance: 3Ω or less </td> </tr> </table>	PNP output	<ul style="list-style-type: none"> Max. source current: 200mA Applied voltage: same as the supply voltage (between control output and +V) Residual voltage: 2.5V or less (at 200mA source current) Leakage current: 200μA or less (also in power OFF state) Maximum load capacity: 1μF (with or without load) Load wiring resistance: 3Ω or less 	NPN output	<ul style="list-style-type: none"> Max. 200mA sink current Applied voltage: same as the supply voltage (between control output and 0V) Residual voltage: 2.0V or less (at 200mA sink current) Leakage current: 200μA or less (also in power OFF state) Maximum load capacity: 1μF (with or without load) Load wiring resistance: 3Ω or less
	PNP output	<ul style="list-style-type: none"> Max. source current: 200mA Applied voltage: same as the supply voltage (between control output and +V) Residual voltage: 2.5V or less (at 200mA source current) Leakage current: 200μA or less (also in power OFF state) Maximum load capacity: 1μF (with or without load) Load wiring resistance: 3Ω or less 			
	NPN output	<ul style="list-style-type: none"> Max. 200mA sink current Applied voltage: same as the supply voltage (between control output and 0V) Residual voltage: 2.0V or less (at 200mA sink current) Leakage current: 200μA or less (also in power OFF state) Maximum load capacity: 1μF (with or without load) Load wiring resistance: 3Ω or less 			
	Output operation	<ul style="list-style-type: none"> ON when all beams of the connected ST4-A□s are received. OFF when one or more beams of the connected ST4-A□s are interrupted 			
	Short circuit protection	Incorporated			
Response time	<ul style="list-style-type: none"> Turn-off time: 25ms or less Turn-on time: 90ms or less (auto-reset)/140ms or less (manual reset) 				
Auxiliary output (Note 1)	PNP or NPN open-collector transistor. Select PNP or NPN output with switch.				
	<table border="1"> <tr> <td>PNP output</td> <td> <ul style="list-style-type: none"> Max. source current: 100mA Applied voltage: same as the supply voltage (between auxiliary output and +V) Residual voltage: 2.5V or less (at 100mA source current) </td> </tr> <tr> <td>NPN output</td> <td> <ul style="list-style-type: none"> Max. 100mA sink current Applied voltage: same as the supply voltage (between auxiliary output and 0V) Residual voltage: 2.0V or less (at 100mA sink current) </td> </tr> </table>	PNP output	<ul style="list-style-type: none"> Max. source current: 100mA Applied voltage: same as the supply voltage (between auxiliary output and +V) Residual voltage: 2.5V or less (at 100mA source current) 	NPN output	<ul style="list-style-type: none"> Max. 100mA sink current Applied voltage: same as the supply voltage (between auxiliary output and 0V) Residual voltage: 2.0V or less (at 100mA sink current)
	PNP output	<ul style="list-style-type: none"> Max. source current: 100mA Applied voltage: same as the supply voltage (between auxiliary output and +V) Residual voltage: 2.5V or less (at 100mA source current) 			
	NPN output	<ul style="list-style-type: none"> Max. 100mA sink current Applied voltage: same as the supply voltage (between auxiliary output and 0V) Residual voltage: 2.0V or less (at 100mA sink current) 			
	Output operation	<ul style="list-style-type: none"> OFF when all beams of the connected ST4-A□s are received. ON when one or more beams of the connected ST4-A□s are interrupted 			
Short circuit protection	Incorporated				
Protection	Enclosure: IP40 (IEC), Terminal area: IP20 (IEC)				
Ambient temperature	-10 to +55°C (No dew condensation or icing allowed),				

Item	Description
	Storage: -25 to +70°C
Ambient humidity	30 to 85% RH, Storage: 30 to 95% RH
Withstand voltage	1,000V AC for one minute (between all supply terminals connected together and enclosure)
Insulation resistance	20MΩ or more with 500V DC (between all supply terminals connected together and enclosure)
Vibration resistance	10 to 55Hz frequency 0.75mm amplitude in X, Y, and Z directions for two hours each
Shock resistance	300m/s ² acceleration in X, Y, and Z directions for three times each
Terminal block	Detachable spring cage terminal
Distributing cable	Terminal block connector: 0.2 to 1.5mm ²
Material	Enclosure: ABS
Weight	Approx. 180g
Applicable standard (Note 2)	IEC 61496-1 (Type 4), ISO 13849-1 (Category 4, PLe) IEC 61508-1 to 7 (SIL3), IEC 62061 (SIL3)



◆ NOTE

1. If the total current of both the control output (OSSD 1/2) and auxiliary output exceeds 400mA, the wiring resistance between the controller and the power supply should be 1Ω or less. In addition, if the total current is 400mA or less, the wiring resistance between the controller and the power supply should be 2Ω or less.
2. Complies with these standards only when the controller is used in combination with the single-beam sensor ST4-□.

6.2 Specifications, Controller ST4-C12EX

Item	Description				
Supply voltage	24V DC ^{±10%} % Ripple P-P 10% or less				
Current consumption	0.12A or less				
Control output OSSD1/2 (Note 1)	PNP or NPN open-collector transistor. Select PNP or NPN output with switch.				
	<table border="1"> <tr> <td>PNP output</td> <td> <ul style="list-style-type: none"> Max. source current: 200mA Applied voltage: same as the supply voltage (between control output and +V) Residual voltage: 2.5V or less (at 200mA source current) Leakage current: 200μA or less (also in power OFF state) Maximum load capacity: 1μF (with or without load) Load wiring resistance: 3Ω or less </td> </tr> <tr> <td>NPN output</td> <td> <ul style="list-style-type: none"> Max. 200mA sink current Applied voltage: same as the supply voltage (between control output and 0V) Residual voltage: 2.0V or less (at 200mA sink current) Leakage current: 200μA or less (also in power OFF state) Maximum load capacity: 1μF (with or without load) Load wiring resistance: 3Ω or less </td> </tr> </table>	PNP output	<ul style="list-style-type: none"> Max. source current: 200mA Applied voltage: same as the supply voltage (between control output and +V) Residual voltage: 2.5V or less (at 200mA source current) Leakage current: 200μA or less (also in power OFF state) Maximum load capacity: 1μF (with or without load) Load wiring resistance: 3Ω or less 	NPN output	<ul style="list-style-type: none"> Max. 200mA sink current Applied voltage: same as the supply voltage (between control output and 0V) Residual voltage: 2.0V or less (at 200mA sink current) Leakage current: 200μA or less (also in power OFF state) Maximum load capacity: 1μF (with or without load) Load wiring resistance: 3Ω or less
	PNP output	<ul style="list-style-type: none"> Max. source current: 200mA Applied voltage: same as the supply voltage (between control output and +V) Residual voltage: 2.5V or less (at 200mA source current) Leakage current: 200μA or less (also in power OFF state) Maximum load capacity: 1μF (with or without load) Load wiring resistance: 3Ω or less 			
	NPN output	<ul style="list-style-type: none"> Max. 200mA sink current Applied voltage: same as the supply voltage (between control output and 0V) Residual voltage: 2.0V or less (at 200mA sink current) Leakage current: 200μA or less (also in power OFF state) Maximum load capacity: 1μF (with or without load) Load wiring resistance: 3Ω or less 			
	Output operation	<ul style="list-style-type: none"> ON when all beams of the connected ST4-A□s are received. OFF when one or more beams of the connected ST4-A□s are interrupted (except during muting) 			
Short circuit protection	Incorporated				
Response time	<ul style="list-style-type: none"> Turn-off time: 25ms or less Turn-on time: 90ms or less (auto-reset)/140ms or less (manual reset) 				
Auxiliary output (Note 1)	PNP or NPN open-collector transistor. Select PNP or NPN output with switch.				
	<table border="1"> <tr> <td>PNP output</td> <td> <ul style="list-style-type: none"> Max. source current: 100mA Applied voltage: same as the supply voltage (between auxiliary output and +V) Residual voltage: 2.5V or less (at 100mA source current) </td> </tr> <tr> <td>NPN output</td> <td> <ul style="list-style-type: none"> Max. 100mA sink current Applied voltage: same as the supply voltage (between auxiliary output and 0V) Residual voltage: 2.0V or less (at 100mA sink current) </td> </tr> </table>	PNP output	<ul style="list-style-type: none"> Max. source current: 100mA Applied voltage: same as the supply voltage (between auxiliary output and +V) Residual voltage: 2.5V or less (at 100mA source current) 	NPN output	<ul style="list-style-type: none"> Max. 100mA sink current Applied voltage: same as the supply voltage (between auxiliary output and 0V) Residual voltage: 2.0V or less (at 100mA sink current)
	PNP output	<ul style="list-style-type: none"> Max. source current: 100mA Applied voltage: same as the supply voltage (between auxiliary output and +V) Residual voltage: 2.5V or less (at 100mA source current) 			
	NPN output	<ul style="list-style-type: none"> Max. 100mA sink current Applied voltage: same as the supply voltage (between auxiliary output and 0V) Residual voltage: 2.0V or less (at 100mA sink current) 			
Output operation	<p>Auxiliary output 1 ON when muting function is disabled OFF when muting function is enabled</p> <p>Auxiliary output 2 ON when override function is disabled OFF when override function is enabled</p> <p>Auxiliary output 3 ON when muting lamp is in normal condition</p>				

Item	Description	
		OFF when muting lamp is in abnormal condition Auxiliary output 4 Negative logic of the control output (OSSD 1/2)
	Short circuit protection	Incorporated
Muting lamp output (Note 1)	Available muting lamp: 24V DC, 1 to 10W	
	Short circuit protection	Incorporated
Protection	Enclosure: IP40 (IEC), Terminal area: IP20 (IEC)	
Ambient temperature	-10 to +55°C (No dew condensation or icing allowed), Storage: -25 to +70°C	
Ambient humidity	30 to 85% RH, Storage: 30 to 95% RH	
Withstand voltage	1,000V AC for one minute (between all supply terminals connected together and enclosure)	
Insulation resistance	20MΩ or more with 500V DC (between all supply terminals connected together and enclosure)	
Vibration resistance	10 to 55Hz frequency 0.75mm amplitude in X, Y, and Z directions for two hours each	
Shock resistance	300m/s ² acceleration in X, Y, and Z directions for three times each	
Terminal block	Detachable spring cage terminal	
Distributing cable	Terminal block connector: 0.2 to 1.5mm ² Power wire connector (A1, A2): 0.2 to 2.5mm ²	
Material	Enclosure: ABS	
Weight	Approx. 180g	
Applicable standard (Note 2)	IEC 61496-1 (Type 4), ISO 13849-1 (Category 4, PL _e) IEC 61508-1 to 7 (SIL3), IEC 62061 (SIL3)	



◆ NOTE

1. If the total current of the control output (OSSD 1/2), auxiliary output, and muting lamp output exceeds 400mA, the wiring resistance between the controller and the power supply should be 1Ω or less. In addition, if the total current is 400mA or less, the wiring resistance between the controller and the power supply should be 2Ω or less.
2. Complies with these standards only when the controller is used in combination with the single-beam sensor ST4-□.

6.3 Specifications, Sensor ST4-A□

Type	Cable length 0.2m		Cable length 1m	
	Model No. (Note 1)	ST4-A1-J02	ST4-A1-J02V (with emission amount adjuster)	ST4-A1-J1
Sensing range	0.1 to 15m			
Standard sensing object	ø9 or more opaque object			
Effective aperture angle (EAA)	±2.5 degree (or less for a sensing range exceeding 3m)			
Supply voltage	Supplied from controller			
Current consumption	Emitter: 11mA or less, Receiver: 9mA or less			
Protection	IP67 (IEC)			
Ambient temperature	-10 to +55°C (no dew condensation or icing allowed) Storage: -25 to +70°C			
Ambient humidity	30 to 85% RH, Storage: 30 to 95% RH			
Ambient illuminance	Incandescent lamp: 3,500lx at the light-receiving surface			
Withstand voltage	1,000V AC for one minute (between all supply terminals connected together and enclosure)			
Insulation resistance	20MΩ or more with 500V DC (between all supply terminals connected together and enclosure)			
Vibration resistance	10 to 55Hz frequency, 0.75mm amplitude in X, Y, and Z directions for two hours each			
Shock resistance	300m/s ² acceleration in X, Y, and Z directions for three times each			
Emitting element	Infrared LED (Peak emission wavelength: 870nm)			
Material	Enclosure: PBT (Polybutylene terephthalate), Lens: Acrylic Indicator cover: Acrylic			
Cable	Shielded cable with connector: 0.2m		Shielded cable with connector: 1m	
Extension cable	Use the optional exclusive cable (see page 93); the total cable length must not exceed 50m (emitter and receiver, respectively, i.e. 100m in total).			
Weight	Emitter: Approx. 20g Receiver: Approx. 25g		Emitter: Approx. 50g Receiver: Approx. 50g	
Applicable standard (Note 2)	IEC 61496-1/2 (Type 4), ISO 13849-1 (Category 4, PLe) IEC 61508-1 to 7 (SIL3), IEC 62061 (SIL3)			



◆ **NOTE**

1. Features encoded in the model no. on the name plate of the product:

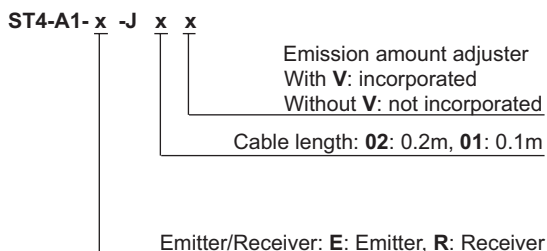

2. Complies with those standards only when the sensor is used in combination with the controller ST4-C11/ST4-C12EX.

6.4 Options

Optional products must be purchased separately.

6.4.1 Extension Cable

You receive 1 set (2 pieces: one for emitter, one for receiver). The emitter cable has a gray connector; the receiver cable has a black connector.

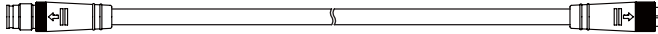

Model No.	Cable length	Remarks	
ST4-CCJ1E	1m	For emitter	
ST4-CCJ1D		For receiver	
ST4-CCJ3E	3m	For emitter	
ST4-CCJ3D		For receiver	
ST4-CCJ5E	5m	For emitter	
ST4-CCJ5D		For receiver	
ST4-CCJ7E	7m	For emitter	
ST4-CCJ7D		For receiver	
ST4-CCJ15E	15m	For emitter	
ST4-CCJ15D		For receiver	

Used to extend the ST4-A□.
5-core shielded cable

6.4.2 Branch Cable

You receive 1 set (2 pieces: one for emitter, one for receiver). The emitter cable has a gray connector; the receiver cable has a black connector.

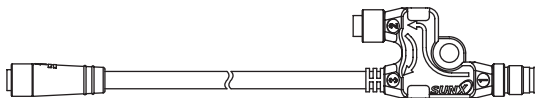

Model No.	Cable length	Remarks
ST4-CCJ05-WY	0.5m	Used to connect multiple units of the ST4-A□. Y type connector 5-core shielded cable

6.4.3 Foot Angled Mounting Bracket

You receive 1 set (2 pieces) including M3 screws with washers (length 12mm).

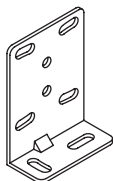

Model No.	Remarks
MS-CX-1	Used to mount at the bottom.

6.4.4 Back Angled Mounting Bracket

You receive 1 set (2 pieces) including M3 screws with washers (length 12mm).

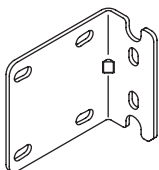

Model No.	Remarks
MS-ST4-3	Used to mount at the back side.

6.4.5 Foot Biangled Protective Mounting Bracket

You receive 1 set (2 pieces) including M5 screws with washers (length 12mm).

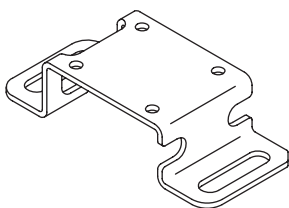

Model No.	Remarks
MS-ST4-6	Used to mount on two positions at the bottom.

6.4.6 Slit Masks

You receive 1 piece.

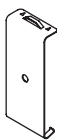

Model No.	Slit size	Sensing range		Remarks
		Mounted on one side	Mounted on both sides	
OS-ST4-2	ø2mm	3m	0.75m	Restrains the amount of the beam emitted or received and hence reduces interference between neighboring sensors.
OS-ST4-3	ø3mm	4.5m	1.5m	

Chapter 7

Dimensions

7.2 Multifunctional Controller ST4-C12EX

Unit: mm

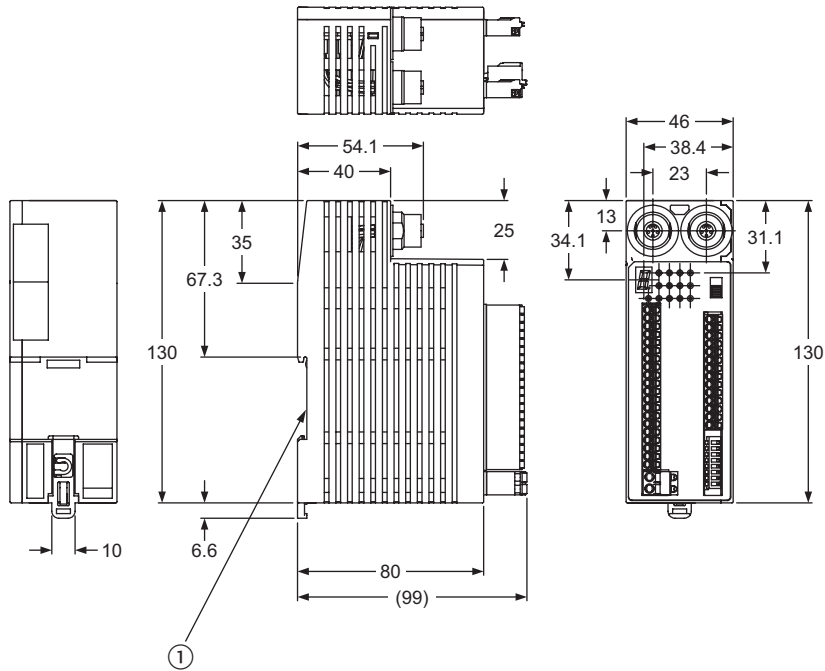

① = Suitable for 35mm width DIN rail

7.3 Single-beam Sensor ST4-A□

Emitter

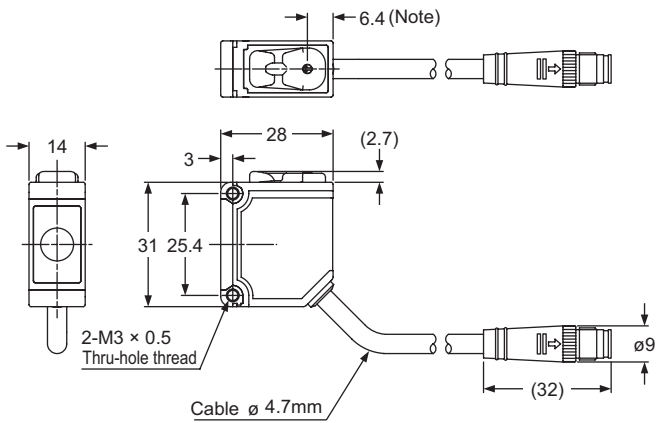

Unit: mm

Receiver

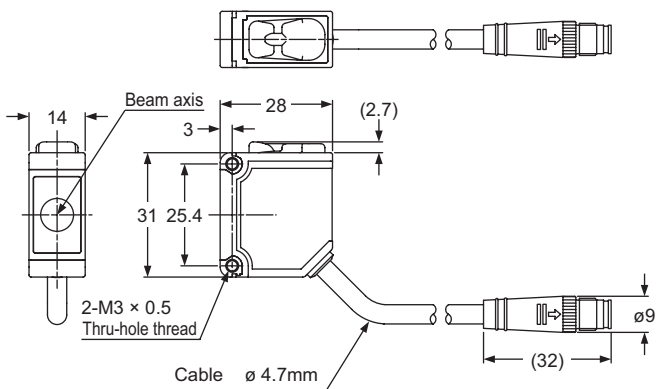

Unit: mm



◆ NOTE

Indicates the position of the emission amount adjuster on the ST4-A□V.

7.5 Foot Angled Mounting Bracket MS-CX-1

Unit: mm

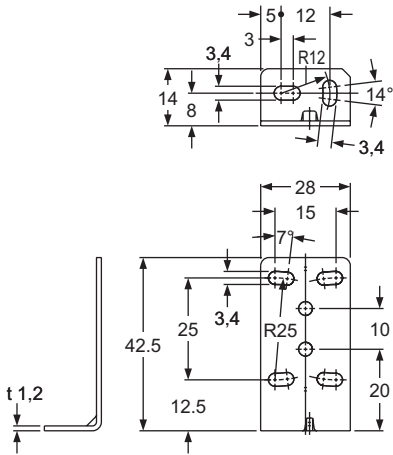

Material: SUS304 (Stainless steel)

7.6 Back Angled Mounting Bracket MS-ST4-3

Unit: mm

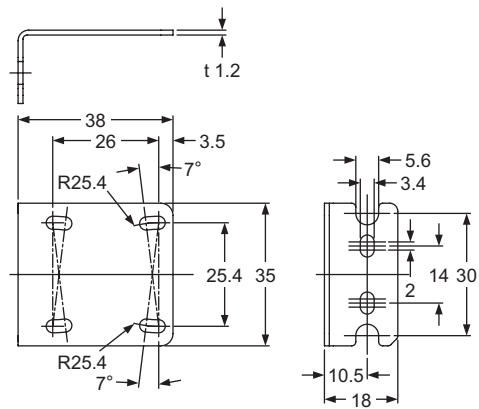

Material: SUS304 (Stainless steel)

7.7 Foot Biangled Protective Mounting Bracket MS-ST4-6

Unit: mm

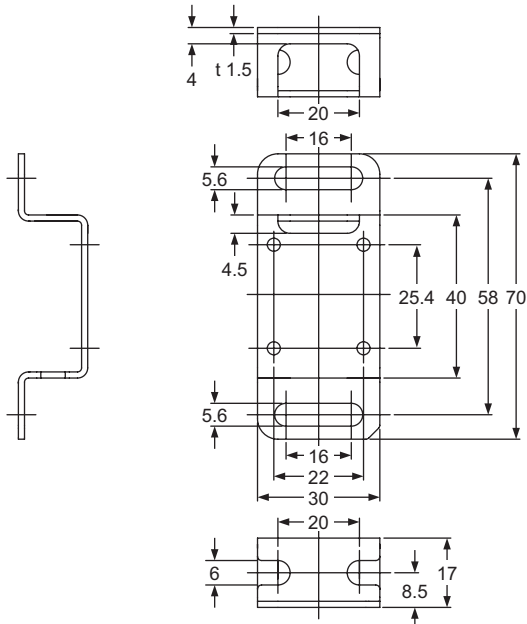

Material: SUS304 (Stainless steel)

Glossary of Terms

Control output (OSSD)

Output Signal Switching Device. A component of the light curtain that turns off when light of the light curtain is blocked.

EMC Directive

On the one hand, the directive relating to electromagnetic compatibility (EMC) governs the electromagnetic emissions of this equipment in order to ensure that, when used as intended, such equipment does not disturb radio, telecommunication or other equipment. On the other hand, the directive also governs the immunity of such equipment to ensure that this equipment is not disturbed by radio emissions normally present when used as intended.

Emission Halt Function

This function enables receiver operation to be checked by turning OFF light emission. Light emission can be halted by keeping the emission halt input terminals between T1 and T2 of the controller open.

EN 55011

This standard specifies the limits and methods of measurement of radio disturbance characteristics of industrial, scientific and medical (ISM) radio-frequency equipment.

EN 61496-1, IEC 61496-1/2, UL61496-1/2, JIS B 9704-1/2

These standards pertain to machine safety, especially electro-sensitive protective equipment (ESPE). EN 61496-1, IEC 61496-1, UL 61496-1 or JIS B 9704-1 define general requirements, examinations and effect analysis, EMC requirements, etc. IEC 61496-2, UL 61496-2 or JIS B 9704-2 specifies effective aperture angle, protection against extraneous light sources, etc, for Active Opto-electronic Protective Devices (AOPDs).

FSD

Final Switching Device. Additional relays between the outputs of the controller and the machinery.

ISO-13849-1 (JIS B 9705-1)

This standard specifies the safety-related matters of machine safety (control system).

Lockout

Lockout is one of the safe states of this device. Operation is stopped if the self-diagnosis function determines that an irrecoverable failure (OSSDs do not operate normally, etc.) has occurred. If an emitter is in the lockout condition, it will stop emitting light. If a receiver is in the lockout condition, the OSSDs are turned OFF.

Machinery Directive

"Machinery" means an assembly of linked parts or components, at least one of which moves, energized by electricity, compressed air, oil pressure, etc. The latest amendment to the directive introduces safety components, placed on the market separately, into its scope.

These are defined as components which are placed on the market "to fulfill a safety function when in use and the failure or malfunctioning of which endangers the safety or health of exposed persons".

PSDI

Presence Sensing Device Initiation. The safety configuration that restarts automatically without any operation by the operator after the device detects the danger status and halts for a while.

Safety distance

The minimum distance that must be maintained between the light curtain and the dangerous parts of a machine so that the machine can be stopped before a human body or an object can reach the dangerous parts.

Sensing area

The range in which the safety light curtain is able to detect objects. The actual size of this range depends on the safety light curtain model.

Sensing height

The sensing height is determined by the number of beam channels +10mm (+5mm at the bottom and +5mm at the top).

Sensing range

The range between the emitter and receiver.

UL1998

UL standard for safety-related software in programmable components.

Index

A

Address allocations.....	25
Adjustment.....	44
Alignment (vertical and horizontal).....	44
Aperture angle.....	20
Auto-reset.....	52, 53
Auxiliary Output.....	56

B

Barrier.....	21
Brackets.....	93, 94, 100, 101, 102

C

Cables.....	93, 99
Calculation of safety distance.....	16, 17, 18
Circuit diagrams.....	37
Controller.....	10, 11, 80, 83, 96, 97

D

Digital error indicator.....	44
Dimensions.....	95
Dismantling.....	29, 30, 31, 32

E

Emission halt function.....	40, 53
Extraneous light.....	79

F

Fault indicator.....	10, 11, 44, 46, 76, 80, 83, 86
----------------------	--------------------------------

I

Inspection checklist.....	76, 77, 78
Installation.....	15, 21, 29, 30, 31

Interference.....	3, 15, 21
Interference prevention function.....	10, 11, 54
Interlock.....	51, 52
Interlock function.....	10, 11, 51, 52

M

Maintenance.....	76, 78
Manual reset.....	51
Maximum cable length.....	23, 92
Maximum response time.....	16, 17, 18
Mounting procedure.....	29, 30, 31, 32
Muting function.....	59, 60
Muting lamp.....	60, 74
Muting pattern selection function.....	67, 68, 69, 70

N

Non-safety output.....	56
NPN output.....	36

O

Operation.....	46, 47
Options.....	93
Output.....	40
Override function.....	63

P

PNP output.....	36
Protective housing.....	15

R

Reflective surfaces.....	20
Reset operation.....	51

S

Safety instructions.....	3
--------------------------	---

Self-diagnosis function.....	50
Sensing area.....	15
Sensing height	15
Sensing range.....	15
Sensor Correct installation.....	15, 44, 46
Sensor extension in series connection ...	32
Slit mask	94
Specifications.....	60, 88, 90, 92
Standards.....	6

T

Terminal arrangement	41
Test.....	46

W

Wiring.....	37, 38, 39, 40
-------------	----------------

EC Declaration of Conformity

We SUNX Limited
of 2431-1, Ushiyama-cho, Kasugai, Aichi 486-0901, Japan

declare that:

Product Safety Beam Sensor
Model name ST4 Series
Trade name SUNX

in accordance with the following Directives:

98/37/EC Machinery Directive (Valid until 29 December 2009)
2006/42/EC Machinery Directive (Valid from 29 December 2009)
2004/108/EC EMC Directive

has been designed and manufactured to the following specifications:

EN 61496-1 : 2004	IEC 61508-4: 1998
IEC 61496-2 : 2006	IEC 62061 : 2005
IEC 61508-1: 1998	EN ISO 13849-1: 2008
IEC 61508-2: 2000	EN 50178 : 1997
IEC 61508-3: 1998	EN 55011 : 2007 +A2 :2007
EN 61000-6-2: 2005	

I hereby declare that the product named above has been designed to comply with the relevant sections of the above referenced specifications. The product complies with all essential requirements of the Directives.

TÜV Certificate

Certificate No. Z10 09 12 19003 041 (Date 10-December-2009)
(by TÜV SÜD Product Service GmbH, Ridlerstrasse 65 80339 München Germany)

Year of CE Marking : 2008

Issued on : 11-December-2009

Signed by the manufacturer :



Name : Takanobu Yada

Position : Divisional General Manager, Sensor Division

Contact :

(Date) 23. December 2009
(Signature) i.v. Christoph Oehler
(Printed name) : Christoph Oehler, Senior Manager IPS
(Company name) : Panasonic Electric Works Europe AG
(Address) Rudolf-Diesel-Ring 2
83607 Holzkirchen, Germany

Addendum to Declaration of Conformity (DoC)

We, Panasonic Electric Works SUNX Co., Ltd.
of 2431-1, Ushiyama-cho, Kasugai, Aichi 486-0901, Japan

comprehensively declare, regardless of previous corporate name, trade name, brand name, and/or brand logo listed below:

The enclosed DoC remains unchanged valid unless it is revised with the present corporate name, trade name, brand name, and/or brand logo.

This declaration concerns the product at hand.

As from 1 October, 2010, corporate name, trade name, brand name, and brand logo are recognized as follows:

Corporate Name

Present:

Previous:

Panasonic Electric Works SUNX Co., Ltd. **SUNX Limited**

Trade and Brand Name

Present:

Previous:

Panasonic

SUNX

Logo

Present:

Previous:

The logo for SUNX, featuring the word "SUNX" in a bold, italicized sans-serif font. A stylized, curved line or swoosh starts under the 'S' and loops around the 'X'.The logo for Panasonic, featuring the word "Panasonic" in a bold, sans-serif font.

Issued on: 1 October 2010

Record of changes

Manual No.	Date	Description of Changes
MEUEN-ST4-V1	January 2010	1st edition

North America | **Europe** | **Asia Pacific** | **China** | **Japan**

Panasonic Electric Works Global Sales Companies

Europe		
▶ Headquarters	Panasonic Electric Works Europe AG	Rudolf-Diesel-Ring 2, 83607 Holzkirchen, Tel. +49(0)8024648-0, Fax +49(0)8024648-111, www.panasonic-electric-works.com
▶ Austria	Panasonic Electric Works Austria GmbH	Rep. of PEWDE, Josef Madersperger Str. 2, 2362 Biedermansdorf, Tel. +43(0)223626846, Fax +43(0)223646133, www.panasonic-electric-works.at
▶ Benelux	PEW Electronic Materials Europe GmbH Panasonic Electric Works Sales Western Europe B.V.	Ennshafenstraße 9, 4470 Enns, Tel. +43(0)7223883, Fax +43(0)722388333, www.panasonic-electronic-materials.com De Rijn 4, (Postbus 211), 5684 PJ Best, (5680 AE Best), Netherlands, Tel. +31(0)499372727, Fax +31(0)499372185, www.panasonic-electric-works.nl
▶ Czech Republic	Panasonic Electric Works Czech s.r.o.	Prumyslová 1, 34815 Planá, Tel. (+420-)374799990, Fax (+420-)374799999, www.panasonic-electric-works.cz
▶ France	Panasonic Electric Works Sales Western Europe B.V.	French Branch Office, B.P. 44, 91371 Verrières le Buisson CEDEX, Tél. +33(0)16013 5757, Fax +33(0)1 6013 5758, www.panasonic-electric-works.fr
▶ Germany	Panasonic Electric Works Deutschland GmbH	Rudolf-Diesel-Ring 2, 83607 Holzkirchen, Tel. +49(0)8024648-0, Fax +49(0)8024648-555, www.panasonic-electric-works.de
▶ Hungary	Panasonic Electric Works Europe AG	Magyarországi Közvellen Kereskedelmi Képviselet, 1117 Budapest, Neumann János u. 1., Tel. +36(0)14829258, Fax +36(0)14829259, www.panasonic-electric-works.hu
▶ Ireland	Panasonic Electric Works UK Ltd.	Dublin, Tel. +353(0)14600969, Fax +353(0)14601131, www.panasonic-electric-works.co.uk
▶ Italy	Panasonic Electric Works Italia s.r.l.	Via del Commercio 3-5 (Z.I. Ferlina), 37012 Bussolengo (VR), Tel. +390456752711, Fax +390456700444, www.panasonic-electric-works.it
▶ Nordic Countries	Panasonic Electric Works Nordic AB PEW Fire & Security Technology Europe AB	Piazza della Repubblica 24, 20154 Milano (MI), Tel. +39022900-5391, Fax +39022900-3466, www.panasonic-building-materials.com Sjöängsvägen 10, 19272 Sollentuna, Sweden, Tel. +4659476680, Fax +46859476690, www.panasonic-electric-works.se
▶ Poland	Panasonic Electric Works Polska sp. z o.o.	Jungmansgatan 12, SE-211 19 Malmö, Tel. +46406977000, Fax +46406977099, www.panasonic-fire-security.com Przedstawicielstwo w Polsce, Al. Krakowska 4/6, 02-284 Warszawa, Tel. +48 22 338-11-33, Fax +48 22 338-12-00, www.panasonic-electric-works.pl
▶ Portugal	Panasonic Electric Works España S.A.	Portuguese Branch Office, Avda Adelino Amaro da Costa 728 R/C J, 2750-277 Cascais, Tel. +351 214812520, Fax +351 214812529
▶ Spain	Panasonic Electric Works España S.A.	Barajas Park, San Severo 20, 28042 Madrid, Tel. +34 91 3293875, Fax +34 91 3292976, www.panasonic-electric-works.es
▶ Switzerland	Panasonic Electric Works Schweiz AG	Grundstrasse 8, 6343 Rotkreuz, Tel. +41(0)417997050, Fax +41(0)417997055, www.panasonic-electric-works.ch
▶ United Kingdom	Panasonic Electric Works UK Ltd.	Sunrise Parkway, Linford Wood, Milton Keynes, MK14 6LF, Tel. +44(0) 1908 231555, +44(0) 1908 231599, www.panasonic-electric-works.co.uk
North & South America		
▶ USA	PEW Corporation of America	629 Central Avenue, New Providence, N.J. 07974, Tel. +1-908-464-3550, Fax +1-908-464-8513, www.pewa.panasonic.com
Asia Pacific/China/Japan		
▶ China	Panasonic Electric Works (China) Co., Ltd.	2013, Beijing Fortune, Building No. 5, Dong San Huan Bei Lu, Chaoyang District, Beijing Tel. +86-10-6590-8646, Fax: +86-10-6590-8647, www.pewc.panasonic.cn
▶ Hong Kong	Panasonic Electric Works (Hong Kong) Co., Ltd.	RM1205-9, 12/F, Tower 2, The Gateway, 25 Canton Road, Tsimshatsui, Kowloon, Hong Kong, Tel. +852 2956-3118, Fax +852 2956-0398
▶ Japan	Panasonic Electric Works Co., Ltd.	1048 Kadoma, Kadoma-shi, Osaka 571-8686, Japan, Tel. +81-6-6908-1050, Fax +81-6-6908-5781 http://panasonic-electric-works.net
▶ Singapore	Panasonic Electric Works Asia Pacific Pte. Ltd.	101 Thomson Road, #25-03/05, United Square, Singapore 307591, Tel. +65-6255-5473, Fax +65-6253-5689