

Hybrid motor starter - ELR H3-I-SC- 24DC/500AC-2 - 2900543

Please be informed that the data shown in this PDF Document is generated from our Online Catalog. Please find the complete data in the user's documentation. Our General Terms of Use for Downloads are valid (<http://download.phoenixcontact.com>)



"2 in 1" hybrid motor starter for starting 3~ AC motors up to 550 V AC, with 24 V DC input, 2.4 A output current, and adjustable overload shutdown.

The figure shows the 9 A version

Product Features

- 22.5 mm wide
- Low-wear switching
- Space saving
- Reduction in wiring
- Long service life
- 3-phase loop bridges
- Bimetal function can be set up to 9 A



Key commercial data

package_quantity	1
GTIN	4046356527682

Technical data

Dimensions

Width	22.5 mm
Height	99 mm
Depth	114.5 mm

Ambient conditions

Ambient temperature (operation)	-25 °C ... 70 °C
Ambient temperature (storage/transport)	-40 °C ... 80 °C
Degree of protection	IP20

Input data

Input name	Device supply
Rated control supply voltage U_s	24 V DC
Voltage range with reference to U_s	0.8 ... 1.25
Rated control supply current I_s	40 mA
Rated actuating voltage U_c	24 V DC

Hybrid motor starter - ELR H3-I-SC- 24DC/500AC-2 - 2900543

Technical data

Input data

Voltage range with reference to U_c	0.8 ... 1.25
Rated actuating current I_c	5 mA
Switching threshold "0" signal, voltage	9.6 V
Switching threshold "1" signal voltage	19.2 V
Protective circuit	Protection against polarity reversal Parallel polarity protection diode
Protective circuit	Surge protection
Typical response time	< 35 ms
Typical turn-off time	< 40 ms
Operating voltage display	Green LED
Status display	Yellow LED
Indication	Red LED
Input name	Control input right/left

Output data

Output name	AC output
Nominal output voltage	500 V AC
Nominal output voltage range	42 V AC ... 550 V AC
Load current	max. 2.4 A (see derating curve)
Rated operating current at AC-51	2.4 A
Rated operating current at AC-53a	2.4 A
Leakage current	0 mA
Residual voltage	< 0.3 V
Surge current	100 A (t = 10 ms)
Type of protection	Surge protection
Output name	Acknowledge output
Note	Confirmation 01: Floating PDT contact
Nominal output voltage	max. 250 V AC
Continuous load current	6 A

Output data, signaling contact

Measuring via	Current transformer for line current on L1 and L3
---------------	---

Connection data

Connection method	Screw connection
Conductor cross section solid min.	0.14 mm ²
Conductor cross section solid max.	2.5 mm ²
Conductor cross section stranded min.	0.14 mm ²
Conductor cross section stranded max.	2.5 mm ²
Conductor cross section AWG/kcmil min.	26
Conductor cross section AWG/kcmil max	14

General

Test voltage input/output	4 kV _{rms}
---------------------------	---------------------

Hybrid motor starter - ELR H3-I-SC- 24DC/500AC-2 - 2900543

Technical data

General

Mounting position	Vertical (horizontal DIN rail)
Assembly instructions	Can be aligned with spacing = 20 mm
Operating mode	100% operating factor
Name	Standards/regulations
Standards/regulations	DIN EN 50178
Standards/regulations	EN 60947
Name	Power station requirements
Standards/regulations	DWR 1300 / ZXX01/DD/7080.8d
Name	Air and creepage distances between the power circuits
Standards/regulations	DIN EN 50178
Rated surge voltage / insulation	6 kV/safe isolation
Rated insulation voltage	500 V
Pollution degree	2
Surge voltage category	III

classifications

eCl@ss

eCl@ss 4.0	27371102
eCl@ss 4.1	27371102
eCl@ss 5.0	27371601
eCl@ss 5.1	27371601
eCl@ss 6.0	27371601
eCl@ss 7.0	27371601
eCl@ss 8.0	27371601

ETIM

ETIM 2.0	EC000066
ETIM 3.0	EC000066
ETIM 4.0	EC000066
ETIM 5.0	EC000066

UNSPSC

UNSPSC 6.01	30211915
UNSPSC 7.0901	39121514
UNSPSC 11	39121514
UNSPSC 12.01	39121514
UNSPSC 13.2	39121514

approvals

UL Listed / cUL Listed / IECCE CB Scheme / UL Listed / cUL Listed / IECCE CB Scheme / cULus Listed /

Hybrid motor starter - ELR H3-I-SC- 24DC/500AC-2 - 2900543

approvals

Approval details

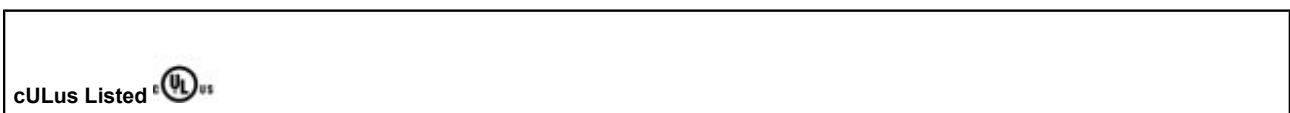
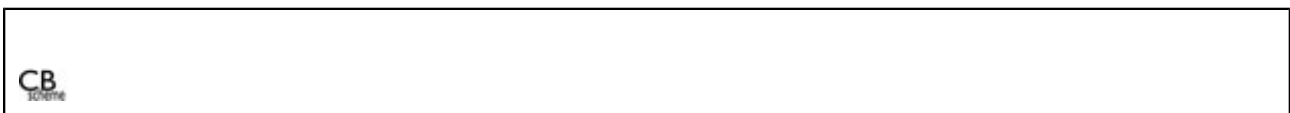
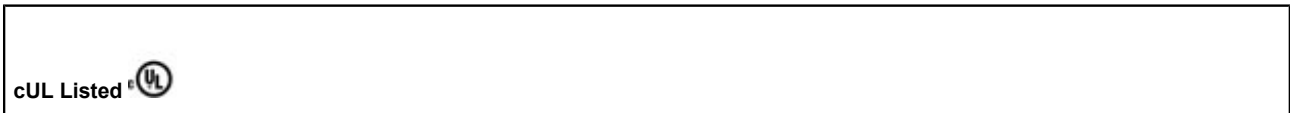

accessories

Loop bridge

BRIDGE- 2 - 2900746



Hybrid motor starter - ELR H3-I-SC- 24DC/500AC-2 - 2900543

accessories

BRIDGE- 3 - 2900747



BRIDGE- 4 - 2900748



BRIDGE- 5 - 2900749



BRIDGE- 6 - 2900750



BRIDGE- 7 - 2900751



BRIDGE- 8 - 2900752



Hybrid motor starter - ELR H3-I-SC- 24DC/500AC-2 - 2900543

accessories

BRIDGE- 9 - 2900753



BRIDGE-10 - 2900754



BRIDGE- 2-3M - 2901543



BRIDGE- 3-3M - 2901656



BRIDGE- 4-3M - 2901659



Hybrid motor starter - ELR H3-I-SC- 24DC/500AC-2 - 2900543

accessories

BRIDGE- 5-3M - 2901545



BRIDGE- 6-3M - 2901697



BRIDGE- 7-3M - 2901698



BRIDGE- 8-3M - 2901700



BRIDGE- 9-3M - 2901701



BRIDGE-10-3M - 2901702



Hybrid motor starter - ELR H3-I-SC- 24DC/500AC-2 - 2900543

accessories

BRIDGE- 2-1M - 2901542



BRIDGE- 3-1M - 2901655



BRIDGE- 4-1M - 2901658



BRIDGE- 5-1M - 2901544



BRIDGE- 6-1M - 2901649



Drawings

Hybrid motor starter - ELR H3-I-SC- 24DC/500AC-2 - 2900543

Block diagram

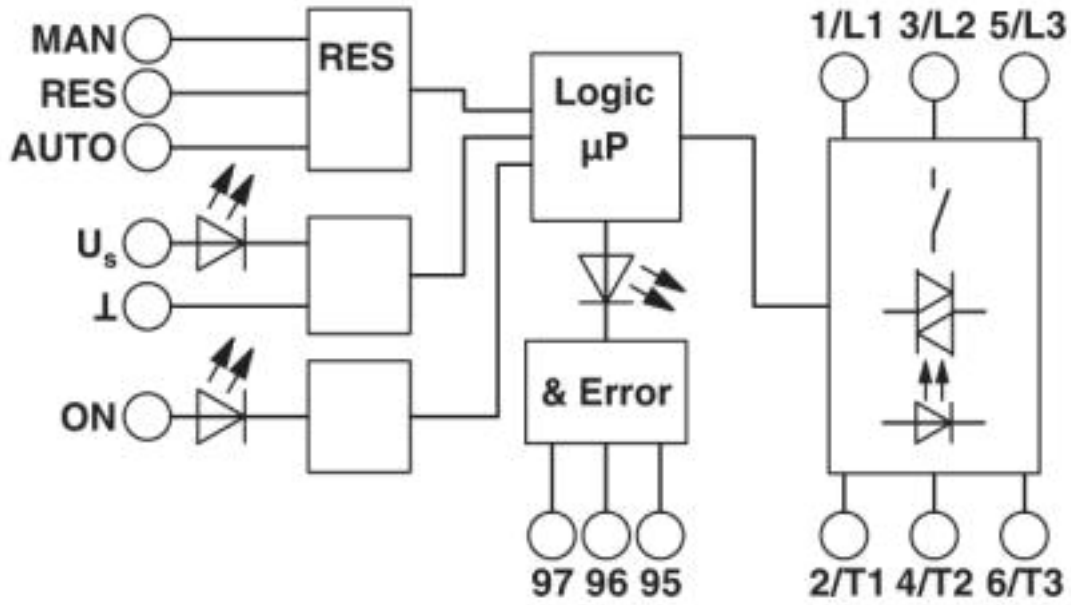

Hybrid motor starter - ELR H3-I-SC- 24DC/500AC-2 - 2900543

Circuit diagram

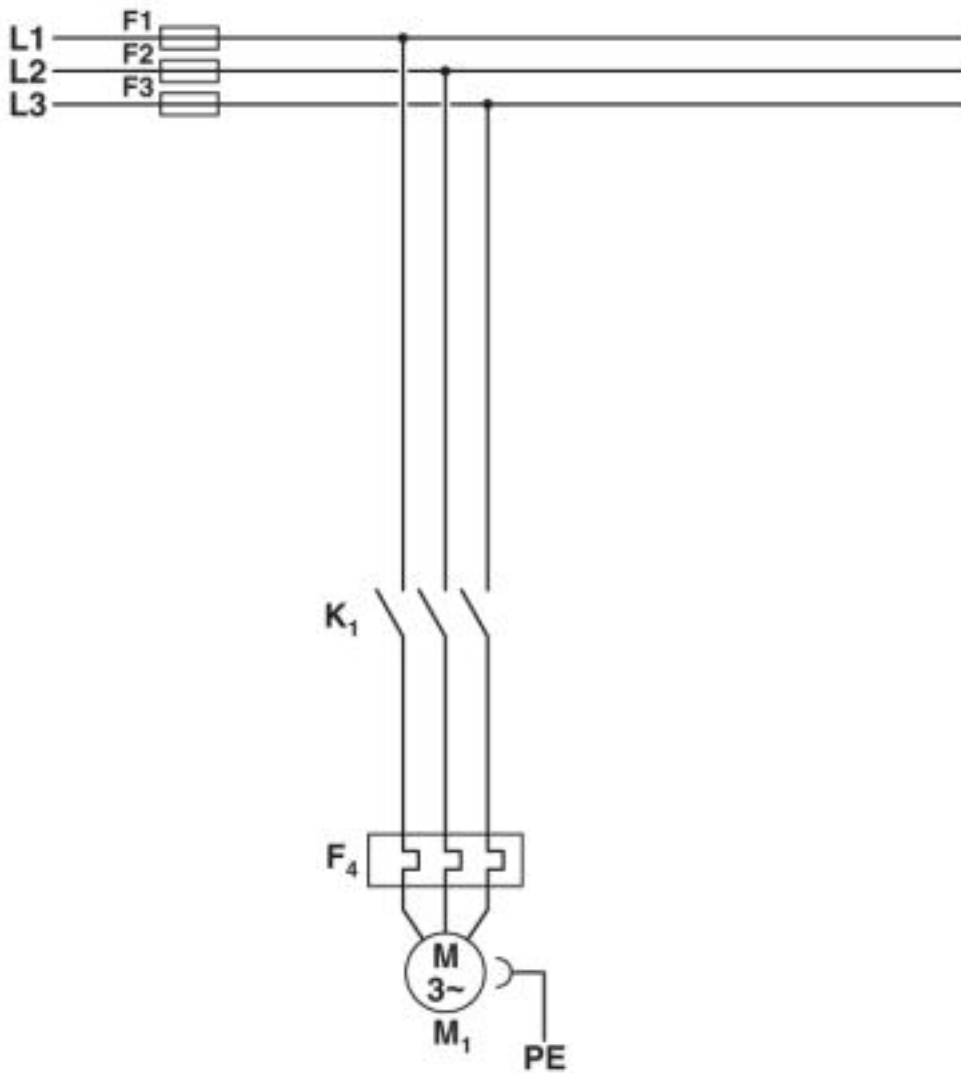

Conventional structure
Main current path reversing contactor K1 = Right contactor
F4 = Motor protection relay

Hybrid motor starter - ELR H3-I-SC- 24DC/500AC-2 - 2900543

Circuit diagram

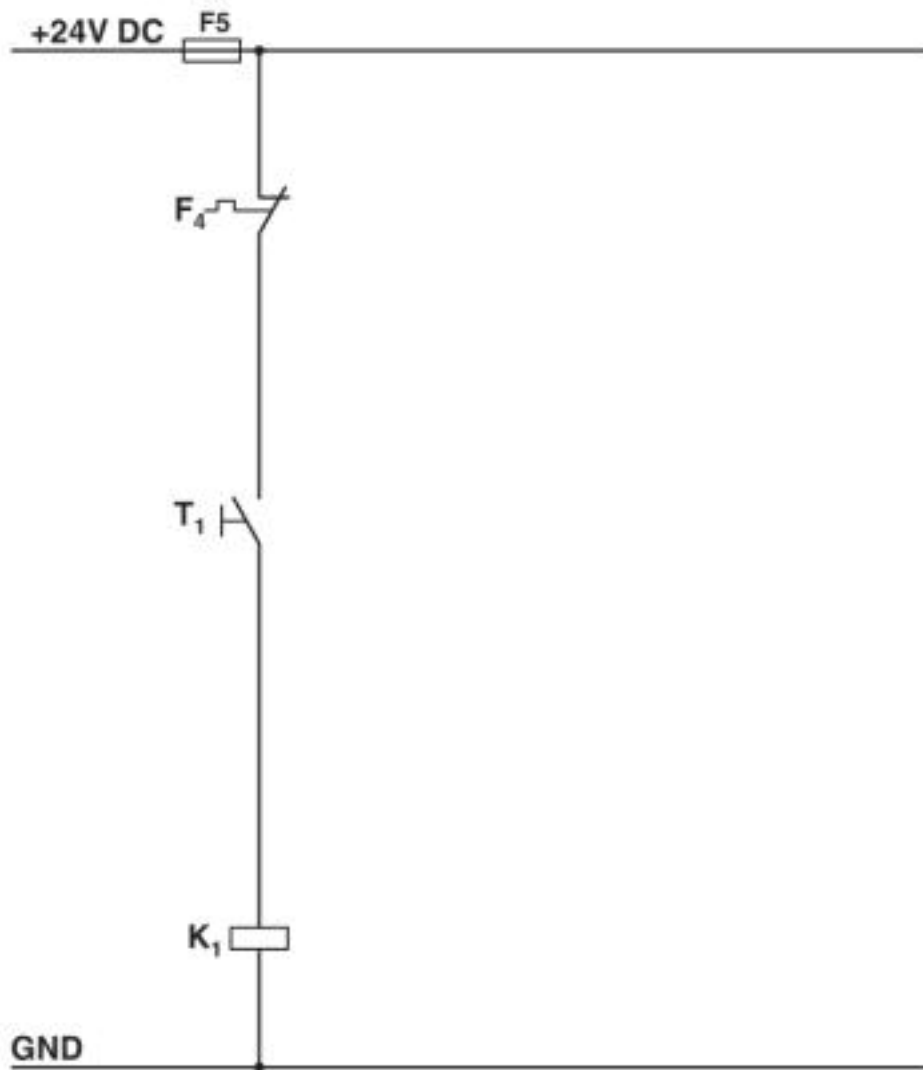

Conventional structure Control current path contactor K1 = Right
contactor T1 = Right F4 = Motor protection relay

Hybrid motor starter - ELR H3-I-SC- 24DC/500AC-2 - 2900543

Circuit diagram

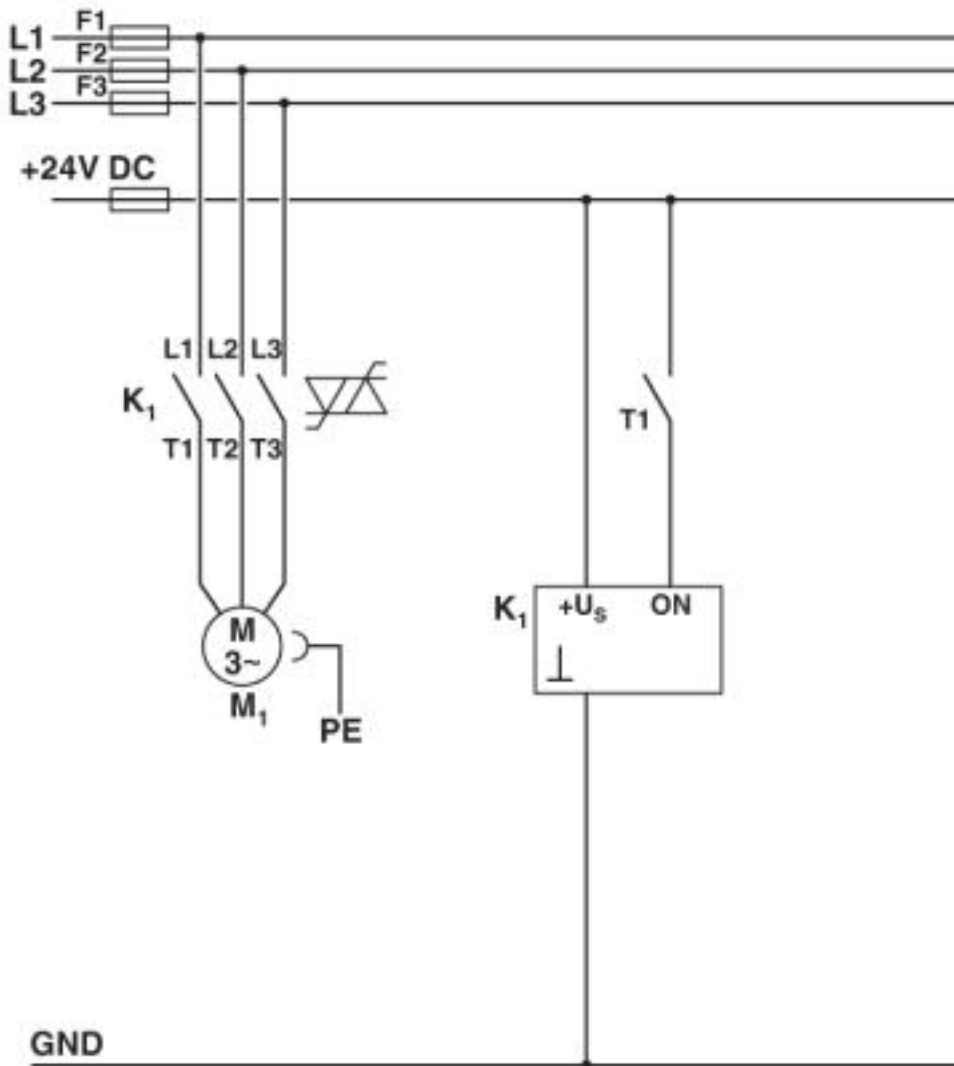

Structure with CONTACTRONMain and control current path for "2 in 1" hybrid motor starter
K1 = "2 in 1" hybrid motor starter
T1 = Right

© Phoenix Contact 2013 - all rights reserved
<http://www.phoenixcontact.com>