



DPP120-XX-1 Din Rail Mountable Switching Power Supply



Technical Data
Installation and Operation

DEFINITION OF MODELS

Output Voltage

DPP120-12-1 : 12V output

DPP120-24-1 : 24V output

DPP120-48-1 : 48V output

Fig. 1

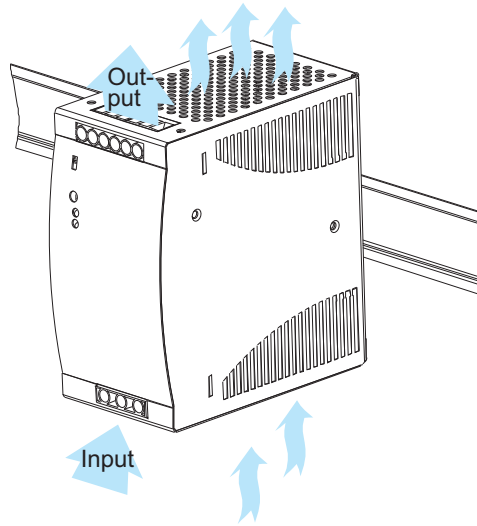

Fig. 2

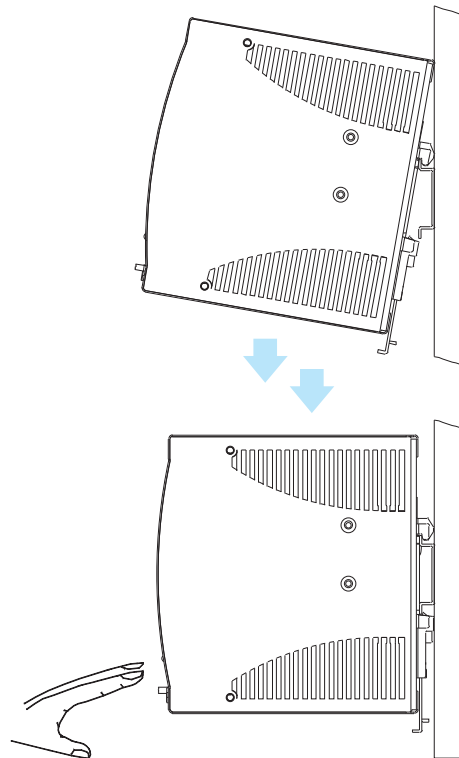
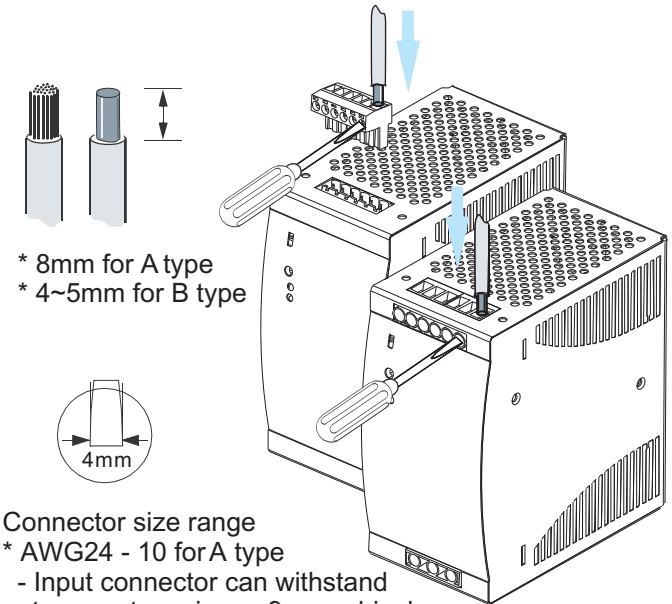

Fig. 3



* 8mm for A type
* 4~5mm for B type

Connector size range

- * AWG24 - 10 for A type
 - Input connector can withstand torque at maximum 9 pound-inches
 - Output connector can withstand torque at maximum 5.5 pound-inches
 - * AWG24 - 14 for B type
 - Connector can withstand torque at maximum 7 pound-inches
- use copper conductors only, 60/75 °C

Fig. 4

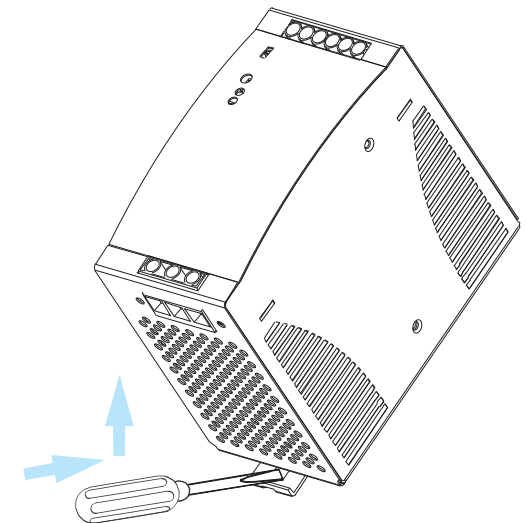



Safety notes

Read Instructions!

Before working with this unit, read these instructions carefully and completely. Make sure that you have understood all the information!

Disconnect system from supply network

Before any installation, maintenance or modification work: Disconnect your system from the supply network. Ensure that it cannot be re-connected inadvertently!

Before start of operation

Ensure appropriate installation

Warning! Improper installation / operation impair safety and result in operational difficulties or complete failure of the unit. The unit must be installed and put into service appropriately by qualified personnel. Compliance with the relevant regulations must be ensured. Before operation is begun the following conditions must be ensured, in particular:

- Connection to main power supply in compliance with VDE01000 and EN50178.
- With stranded wires: all strands must be secured in the terminal blocks (potential danger of short circuit).
- Unit and power supply cables must be properly fused; if necessary a manually controlled disconnecting element must be used to disengage from supply mains.
- The non-fused earth conductor must be connected to the "⊕" terminal (protection class 1).
- All output lines must be rated for the power supply output current and must be connected with the correct polarity.
- Sufficient air-cooling must be ensured.

In operation: No modifications!

As long as the unit is in operation: do not modify the installation! The same applies also to the secondary side. Risk of electric arcs and electric shock (fatal)!

Only connect/disconnect plug connectors when the power is off!

Convection cooling (See Fig. 1)

Do not cover any ventilation holes!
Leave sufficient space around the unit **for cooling!**

Warning: High voltage! Stored energy!

The unit contains unprotected conductors carrying a lethal high voltage, and components storing substantial amounts of energy. Improper handling may result in an electric shock or serious burn!

- The unit must not be opened except appropriately trained personnel!
- Do not introduce any object into the unit!
- Keep away from fire and water!

Installation

Application

This unit is a primary switched-mode power supply designed for use in panel-board installations or building-in applications where access to the supply is restricted (shock-hazard protection). It must only be installed and put into service appropriately by qualified personnel.

Mounting

Mounting (See Fig. 1)

Permissible mounting position: keep free ventilation hole, leave space for cooling! Recommended to have 25mm free space at all sides for ventilation / cooling.

Snap on support rail (See Fig. 2)

- Tilt the unit slightly rearwards.
- Fit the unit over top hat rail.
- Slide it downward until it hits the stop.
- Press against the bottom front side for locking.
- Shake the unit slightly to check the locking action.

Front elements

Operation indicator

Indicates whether the unit is working properly. Green LED is lit if the voltage at the output terminal is more than 75%.

DC output low indicator

Red LED is lit when the voltage at the output terminal is 70% to 90% of the rated output voltage.

Potentiometer

Used to set the output voltage.

Technical Data

All specifications are typical at nominal line, full load, 25°C; Unless otherwise noticed.

Output Wattage	VO [V]	Io [A]	Eff. [typ.]	Inrush Current	
				115Vac	230Vac
120	12	10	84%	< 24A	< 48A
	24	5	86%		
	48	2.5	87%		

General Specification

Isolation	3000 Vac / 4242 Vdc
Isolation Resistance.....	100 M ohm
Operation amb. Temperature....	-25 ~ +71 °C
Storage Temperature.....	-25 ~ +85 °C
Derating.....	+61 ~ +71 °C (see Fig. 5)
Relative Humidity.....	95% RH
Cooling.....	Free air convection
Temperature Coefficient.....	0.02% / °C
Dimension.....	L123.6 x W63.5 x D123.6 [in mm] for A type L143 x W63.2 x D123.6 [in mm] for B type
Weight.....	920g

Fig. 5 Derating

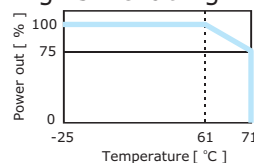

Connection / Internal fuse

Connection (See Fig. 3)

- Data for permitted loads, cable cross-sections and stripping.
- Use only commercial cables designed for the indicated voltage and current values!
- With flexible cables: make sure that all stranded cable are secured in the terminal.
- Ensure proper polarity at output terminals!

Grounding

- **Do not operate without PE connection!** To comply with EMC and safety standards (CE mark, approvals), the unit must only be operated if the PE terminal ⊕ is connected to the non-fused earth conductor.
- Secondary side is not earthed; if necessary the ⊕ or ⊖ terminal can be earthed optionally.

Internal fuse

The internal input fuse serves to protect the unit and must not be replaced by the user. In case of an internal defect, the unit must be returned to the manufacturer for safety reasons.

Removal

Removal from DIN Rail

Insert a flat screwdriver into the slot in the clamp. Pull down the clamp out until the clamp clicks, and turn the switching power supply bottom out. (See Fig. 4)

Input Specification

Input Voltage Range.....	AC 115 Vac (90 ~ 132 Vac)
(Auto Select)	AC 230 Vac (186 ~ 264 Vac)
	DC 210 ~ 370 Vdc

Output Specification

Output Accuracy.....	-0%, +1%
Line Regulation	± 0.5%
Load Regulation.....	± 1% for single mode ± 5% for parallel mode
Ripple & Noise	50 mV 11.4 ~ 14.5 Vdc for 12V models
Voltage Trim Range.....	22.5 ~ 28.5 Vdc for 24V models 45 ~ 55 Vdc for 48V models
Hold up time.....	>25ms
DC ON Indicator.....	Green LED
DC LOW Indicator.....	Red LED
Parallel Operation.....	3 unit max.

Control And Protection

Input Internal Fuse.....	T3.15A / 250 Vac
Output Short Circuit	By Fold Forward
Output Over Load.....	110 % ~ 145 %

Approvals And Standard

UL / cUL.....	UL 508 Listed , UL 60950-1 Recognized
TUV	EN 60950-1
CE.....	EN 55022 & EN 61000-6-3, EN 61000-3-2, EN 61000-3-3, EN 55024 & EN 61000-6-2, EN 61000-4-2, EN 61000-4-3, EN 61000-4-4, EN 61000-4-5, EN 61000-4-6, EN 61000-4-8, EN 61000-4-11