

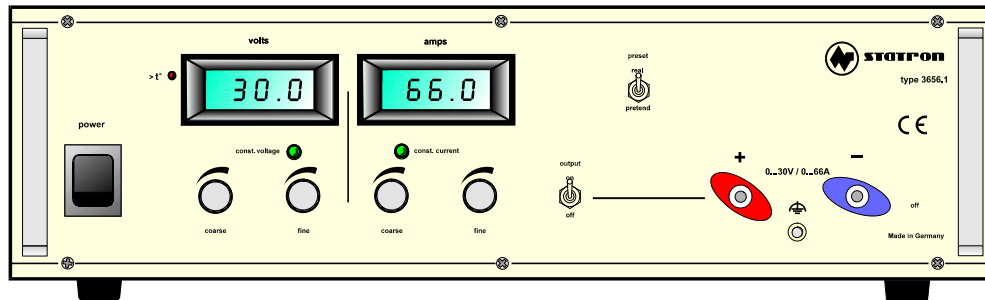

STATRON

Gerätetechnik GmbH

switching power supply type 3656.1



The connection and business of low voltage consumers with an operating voltage between 0 and 30 V direct voltage. The current consumption of the consumer mustn't exceed 66 amps.

Respect! Read absolutely!

These read through these instructions exactly. The right to claim under guarantee dies at damages which are caused by no observance of the instructions. For resultant damages we don't assume any liability.

1. introduction for the switching power supply

This power supply unit is of tension with his direct one moving possibilities and current is universally usable for industry, research and education.

An electronic current limitation protects the power supply unit from overload.

Output voltage is current electronically stabilized and directly adjustably and -- . The electronic current stabilization can therefore be used to protect consumers from one to high current consumption as adjustable current limitation. The output voltage then becomes at an overload according to drop (at short-circuit on near 0 V). This one overlooked at elimination the before oriented output voltage automatically again. One becomes the respective work condition, tension, (cv) or current stabilization (cc) LED reported by ever.

The oriented results are a 3 ½ digit LCD indication 13 mm readable over ever. The tension or current attitude carried out about rough -- and fine-tuning control.

2. Sicherheitshinweise

- 2.1 Die Sicherheit entspricht der DIN. Die Transformatoren entsprechen der DIN und sind primär/sekundär mit 3,75 kV_{eff} geprüft. The power supply unit is built up in safety class I as well as in accordance with EN61010 und DIN EN 60950 . The net transformer is built up after EN 61558 as safety separating transformer and is checked with 3.75 kV_{eff} primarily/secondarily. It is 0875th it is equipped with a VDE checked mains power line with protection leader and may be operated or attached only at 230~V alternating voltage nets with protective earthing therefore radio suppressed in accordance with VDE.
- 2.2 It has to be respected on this that the protection leader is interrupted (yellow/green) neither in the mains power line nor in the piece of equipment or in the net since with interrupted protection leader there is serious danger. It has to be respected on this furthermore that the insulation is neither damaged nor destroyed.
- 2.3 **power supply units don't belong child hands in!**
- 2.4 The accident prevention regulations of the association of the commercial employers mutual insurance association have to be observed for electrical plants and operating supplies in commercial facilities.
- 2.5 Operating power supply units by trained staff is responsible to supervise to hobby and alone help workshops in schools, education facilities.
- 2.6 Open of shutters or remove of parts at this, unless if this is possible by hand, voltage-carrying parts can be exposed. Junctions also can be voltage-carrying. The piece of equipment must be separated from all voltage sources in front of a comparison, a maintenance, an overhaul or an exchange of parts, if a opening the piece of equipment is required. After one, at the open piece of equipment under tension unavoidably is comparison, a maintenance or a repair, may happen only by a qualified employee which is familiar with the thus obliged dangers or the appropriate regulations for this if.
- 2.7 Condensers in the piece of equipment still can be loaded even if the piece of equipment was separated from all voltage sources.
- 2.8 It has to be guaranteed that only safeguarding of rated current said the given type and this one are used as a substitute. The use of mended safeguarding or bridging of the fuse holder are inadmissible. The piece of equipment is overtaxing safe and short-circuit protected. There is a grave fault to blow of the initial safeguarding which must be removed by a qualified employee before the new intact safeguarding can be used by this qualified employee.
- 2.9 Never switch your power supply unit on immediately, if it is taken to a warm room from a cold, then. The condensation arising at dewfall can destroy your piece of equipment under unfavourable circumstances. Let the piece of equipment switched off on room temperature come.
- 2.10 At works with power supply units carrying is forbidden to rings by metallic or conductive jewellery like chains, bracelets, or the like.
- 2.11 Power supply units aren't allowed for the application at people or animals.
- 2.12 Critical tensions (> 35 VDC) are caused at the series connection of the exits of one or several power supply units.
- 2.13 Ventilation slits of power supply units may not be covered! The pieces of equipment have to be moved to hard, heavily inflammable documents so that the air can unhindered enter the pieces of equipment. The cooling of the pieces of equipment is made by forced ventilation.
- 2.14 Power supply units and the attached consumers may not be operated for uncontrolled. It is (measures z to the protection and the safeguarding of the attached consumers opposite effects of the power supply units. B. overloads, failure of the power supply unit) and meet effects and going out dangers (e.g. inadmissibly high current consumption) of the consumers this one.
- Respect! Sensitive consumers must in addition be protected from destruction by external measures!**
- 2.15 In the fault case power supply units can give V direct voltage to tensions over 50 of which dangers start out, also then if the given output voltages of the pieces of equipment lie more lowly.
- 2.16 At works under tension tool only allowed particularly for this may be used.
- 2.17 (the exits of the power supply units/and lines attached to this must be protected from direct touch output jacks-stick). The used lines must have a sufficient isolation or tension strength and be touch sure the contact points (safety sockets) to this.
- 2.18 Transferring metallic shiny lines and contacts has to be avoided. All these places have to be covered by suitable, heavily inflammable insulant or other measures and protected which from direct touch. The electrically leading parts of the attached consumers also have to be protected from direct touch by corresponding measures.
- 2.19 To be assumed has that a safe business is no longer possible, it is to put apart from business and to safeguard against unintentional business the piece of equipment so if. It has to be assumed, that a safe operating no longer possible if:

- the piece of equipment or the power cord shows visible damages --
- the piece of equipment doesn't work -- any more
- after longer storage under unfavourable conditions
- after heavy transport uses

3. Operation

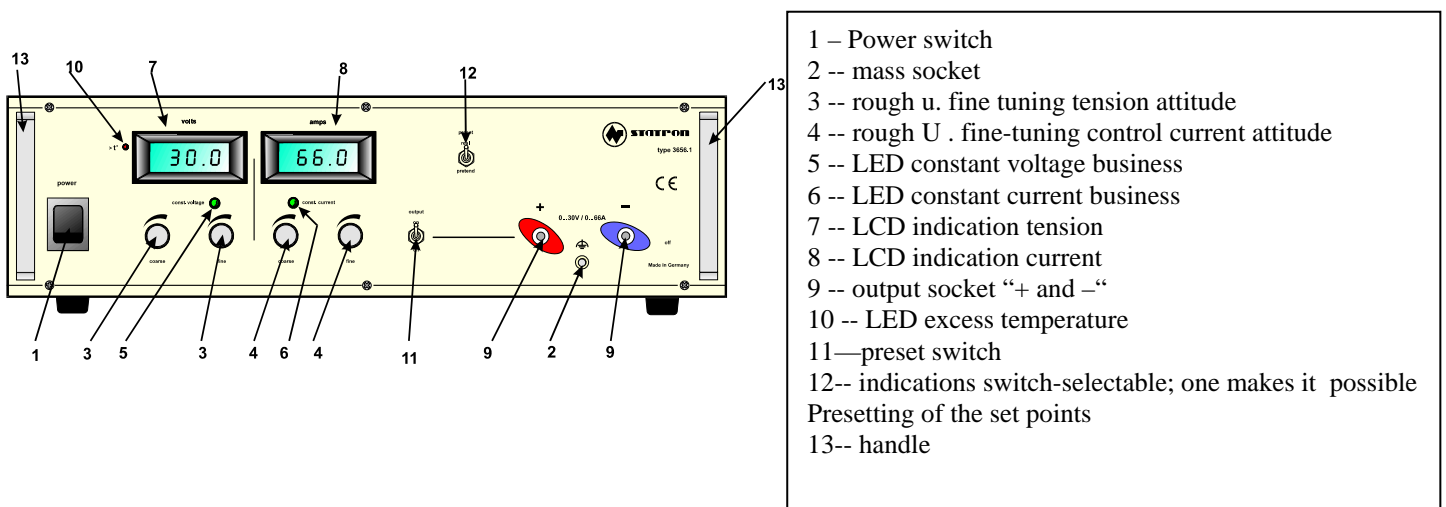

- 1 – Power switch
- 2 -- mass socket
- 3 -- rough u. fine tuning tension attitude
- 4 -- rough U . fine-tuning control current attitude
- 5 -- LED constant voltage business
- 6 -- LED constant current business
- 7 -- LCD indication tension
- 8 -- LCD indication current
- 9 -- output socket “+ and -“
- 10 -- LED excess temperature
- 11—preset switch
- 12-- indications switch-selectable; one makes it possible Presetting of the set points
- 13-- handle

4. putting into operation are

a) connection

Plug the shock proof plug of the power supply unit in to a safety contact electrical outlet 230 V/(50 Hz) and switch the power supply unit on about the power switch.

Respect!

With longer business with maximum current withdrawal (66 amps) or at short-circuit the cool body gets very warm in the power supply unit. An overload of the power supply is reported to LED "excess temperature" by the red. The exit data fall against zero simultaneously.

You pay attention therefore absolutely to a sufficient ventilation of the power supply unit the air leaving opening of the coercive cooling and never conceal they the ventilation slits at the piece of equipment underside and at the rear.

The availability of the maximum output current in the permanent operation immediately depends on an optimal cooling and the surroundings temperature.

Take care at the connection of a consumer absolutely that this isn't attached in the condition switched on. A consumer switched on can lead to a spark formation at the connection to the output terminals of the power supply unit at the terminals which the ports or the attached lines and/or whose clamps can damage in turn.

The short-term mode of the piece of equipment is the LED (5) and (6) recognizable to.

b) presetting of maximum tensions and current exit results

You press in the condition of the power supply unit switched on without for attached consumer for the presetting switch for "preset" .An the LCD-displays are readably the at the moment at most attainable exit results now directly. The handicap results can by the adjust belonging Potentiometer to the desired application case to this.

Respect!

Follow the safety notes absolutely under section 2 of these instructions.

Technical data

Operating voltage	230 V AC +10 / -10%
Mains frequency	48 bis 62 Hz
Current consumption	max. 12A <0,98
Output voltage	0,01 ... 30,5V
Output current	0,0166,6A
Tension stability +6/-10% net fluctuation Burden end rope at 100% burden change	<2mV <10mV
Current stability at +6/-10% net fluctuation	<15mA
Residual ripple at mentioning burden	<50mVss / 6mVeff <55mAss / 22mAeff
display	digital LCD 3½ digit 13mm für voltage and current separate
cooling	temperature regulated ventilator
test voltage	EN 61010; EN 61558-2-4
EMV	DIN EN 61204-3 Klasse A
Weight	16 Kg
Measurements (B x H x T) Surroundings conditions	445 x 134 x 440 mm IP 30 / I

Protection degree; Safety class

Business temperature area	+10 °C ... 20 ... +35 °C
relative atmospheric humidity.	max. 85 %
Air pressure	800 bis 1333 hPa

Warning: This type is a class A. Close by cannot radio interference. This type not for living quarters.

Subject to alterations!

STATRON Gerätetechnik GmbH

Ehrenfried-Jopp-Straße 59

15517 Fürstenwalde

Telefon: (03361) 37 21 01

Fax: (03361) 37 21 03

e-mail: statron@statron.deInternet: www.statron.de