

TDK-Lambda

DPP120-XX-3

Din Rail Mountable
Switching Power Supply



Technical Data
Installation and Operation

DEFINITION OF MODELS

Output Voltage

DPP120-12-3 : 12V output

DPP120-24-3 : 24V output

Fig. 1

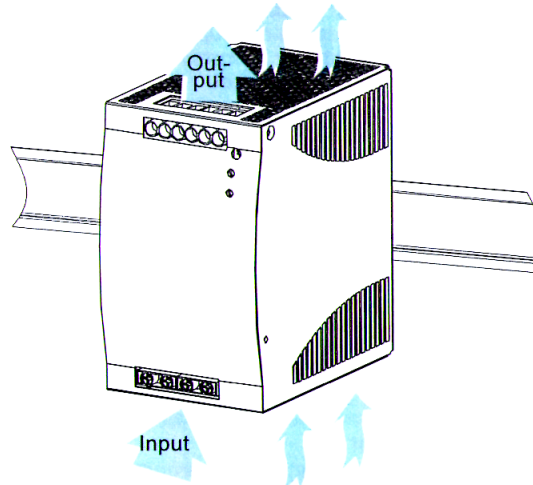

Fig. 2

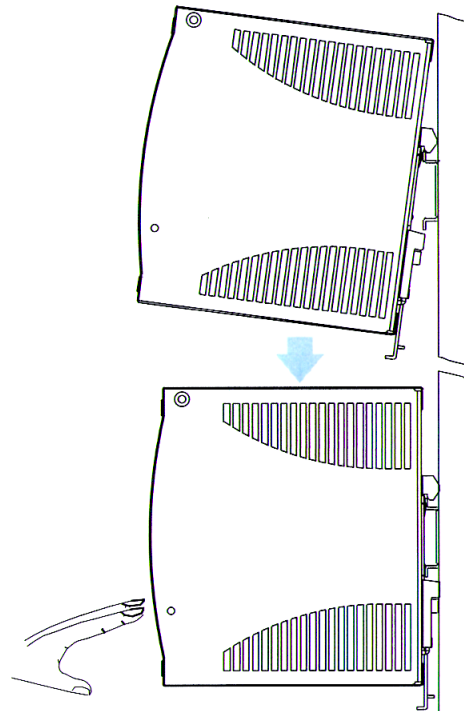
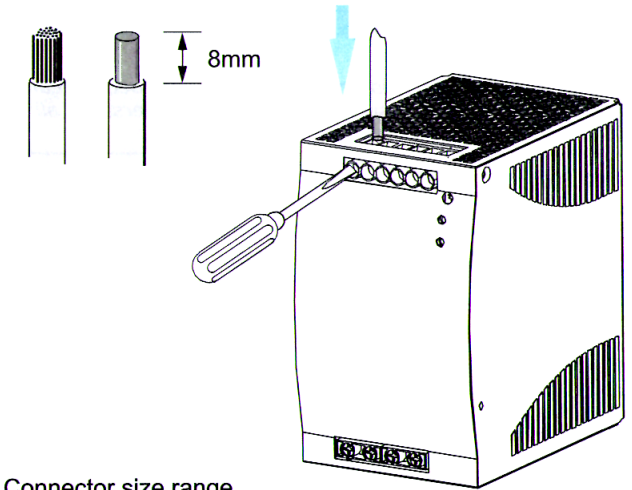

Fig. 3



Connector size range

* AWG24 - 10

- Input connector can withstand torque at maximum
1.01Nm (9 pound-inches)

- Output connector can withstand torque at maximum
0.62Nm (5.5 pound-inches)

Use copper conductors only, 60/75 °C

Max. Surrounding Air Temperature of 55 °C

Fig. 4

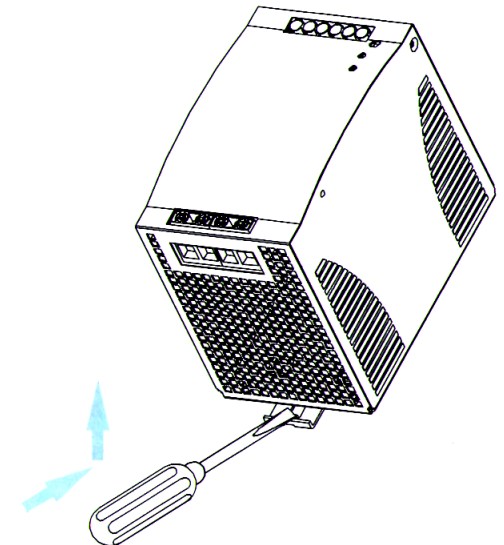



Safety notes

Read Instructions!

Before working with this unit, read these instructions carefully and completely. Make sure that you have understood all the information!

Disconnect system from supply network

Before any installation, maintenance or modification work: Disconnect your system from the supply network. Ensure that it cannot be re-connected inadvertently!

Before start of operation Ensure appropriate installation

Warning! Improper installation / operation impair safety and result in operational difficulties or complete failure of the unit. The unit must be installed and put into service appropriately by qualified personnel. Compliance with the relevant regulations must be ensured. Before operation is begun the following conditions must be ensured, in particular:

- Connection to main power supply in compliance with VDE01000 and EN50178.
- With stranded wires: all strands must be secured in the terminal blocks (Potential danger of short circuit).
- Unit and power supply cables must be properly fused; if necessary a manually controlled disconnecting element must be used to disengage from supply mains.
- The non-fused earth conductor must be connected to the "⊕" terminal (protection class 1).
- All output lines must be rated for the power supply output current and must be connected with the correct polarity.
- Sufficient air-cooling must be ensured.
- pollution degree 2 environment.

In operation: No modifications!

As long as the unit is in operation: do not modify the installation! The same applies also to the secondary side. Risk of electric arcs and electric shock (fatal)!

Only (dis) connect plug connectors when the power is off!

Convection cooling (See Fig. 1)

Do not cover any ventilation holes!
Leave sufficient space around the unit for cooling!

Warning: High voltage! Store energy!

The unit contains unprotected conductors carrying a lethal high voltage, and components storing substantial amounts of energy. Improper handling may result in an electric shock or serious burn!

- The unit must not be opened except appropriately trained personnel!
- Do not introduce any object into the unit!
- Keep away from fire and water!

Installation

Application

This unit is a primary switched-mode power supply designed for use in panel-board installations or building-in applications where access to the supply is restricted (shock-hazard protection). It must only be installed and put into service appropriately by qualified personnel.

Mounting

Mounting (See Fig. 1)

Permissible mounting position: keep free ventilation hole, leave space for cooling! Recommended to have 25mm free space at all sides for ventilation / cooling:

Snap on support rail (See Fig. 2)

- Tilt the unit slightly rearwards.
- Fit the unit over top hat rail.
- Slide it downward until it hits the stop.
- Press against the bottom front side for locking.
- Shake the unit slightly to check the locking action.

Front elements

Operation indicator

Indicates whether the unit is working properly. Green LED is lit on if the voltage at the output terminal is more than 75%.

DC output low indicator

Red LED is lit when the voltage at the output terminal is 70% to 90% of the rated output voltage.

Potentiometer

Used to set the output voltage.

Connection / Internal fuse

Connection (See Fig. 3)

- Data for permitted loads, cable cross-sections and stripping:
- Use only commercial cables designed for the indicated voltage and current values!
- With flexible cables: make sure that all stranded cable are secured in the terminal.
- Ensure proper polarity at output terminals!

Grounding

- **Do not operate without PE connection!** To comply with EMC and safety standards (CE mark, approvals), the unit must only be operated if the PE terminal ⊕ is connected to the non-fused earth conductor.
- Secondary side is not earthed; if necessary the ⊕ or ⊖ terminal can be earthed optionally.

Internal fuse

The internal input fuse serves to protect the unit and must not be replaced by the user. In case of an internal defect, the unit must be returned to the manufacturer for safety reasons.

External circuit breaker

- For input line protection observe national regulations; recommended recommended circuit breaker: Mitsubishi, Type NF30-CS, rated 20A max or equipollent of TUV/VDE/UL approved sources.

Removal

Removal from DIN Rai (See Fig. 4)

Insert a flat screwdriver into the slot in the clamp. Pull the clamp down until it clicks off the Din rail, then, from the bottom, lift the power supply up and away.

Technical Data

All specifications are typical at nominal line, full load, 25°C; Unless otherwise noticed.

Output Wattage	VO [V]	Io [A]	Eff. [typ.]	Inrush Current
				400/500Vac
120	12	10	87%	< 10A
	24	5	89%	

General Specification

Isolation 3000 Vac / 4242 Vdc
 Isolation Resistance 100 M ohm
 Operation amb. Temperature -25 ~ +71 °C
 Storage Temperature -25 ~ +85 °C
 Derating +61 ~ +71 °C (see Fig. 5)
 Relative Humidity 20 ~ 95% RH
 Cooling Free air convection
 Temperature Coefficient 0.03% / °C
 Dimension L124 x W74.3 x D118.8 [mm]
 Weight 800g

Input Specification

Rated Input Voltage 3ø 400-500 Vac
 Input Voltage Range 3ø 340 ~ 575 Vac
 Rated Input Current 0.5A
 Line Frequency 47 - 63 Hz
 Power Factor 0.55

Output Specification

Output Accuracy -0%, +1%
 Line Regulation +/- 1%
 Load Regulation +/- 1%
 Ripple & Noise 100 mV
 Voltage Trim Range 11.4 ~ 14.5 Vdc for 12V model
 22.5 ~ 28.5 Vdc for 24V model
 DC ON Indicator Green LED
 DC LOW Indicator Red LED
 Turn on time <1000ms
 Fall time <150ms
 Rise time <150ms
 Hold Up Time >20ms
 Case material Metal

Control And Protection

Input Internal Fuse 2A / 600 Vac internal / phase
 Output Short Circuit Current limited
 Output Over Load 115 % ~ 135 %

Approvals And Standard

UL / cUL UL 508 Listed, UL 60950-1 Recognized
 TUV EN 60950-1
 CE EN 61000-6-3, EN 55022 class B
 EN 61000-3-2, EN61000-3-3
 EN 61000-6-2, EN 55024
 EN 61000-4-2, -3, -4, -5, -6, -8, -11
 EN 61204-3

Fig. 5 Derating

