

Top View of Assembly

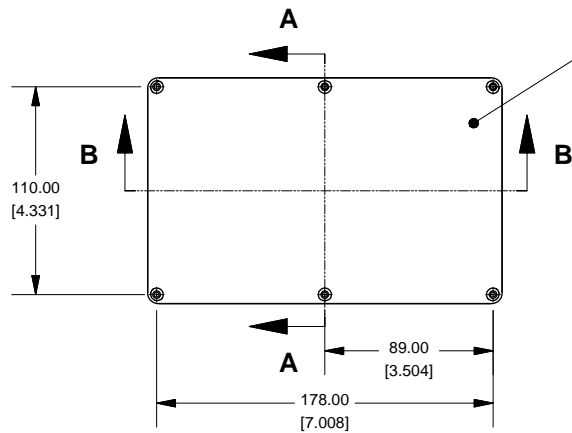

SECTION A-A
End View of Assembly

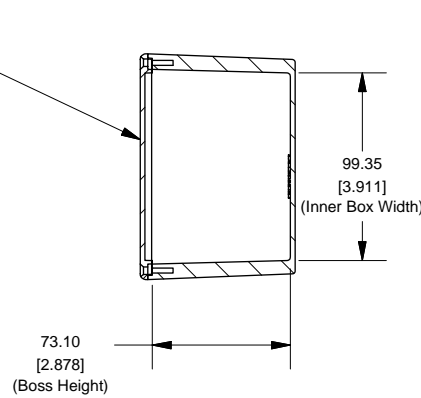

Series 1590E

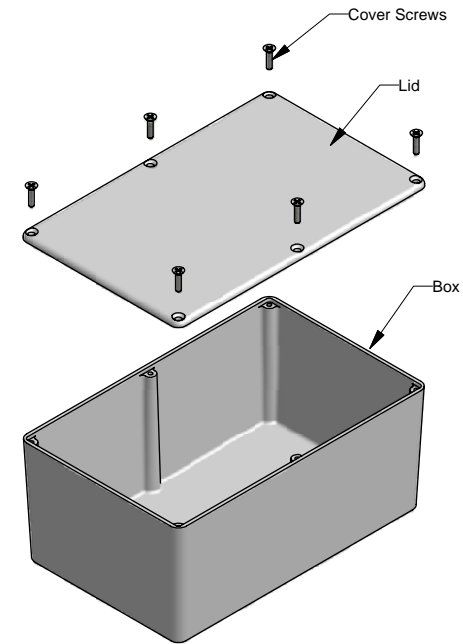

SECTION B-B
Side View of Assembly

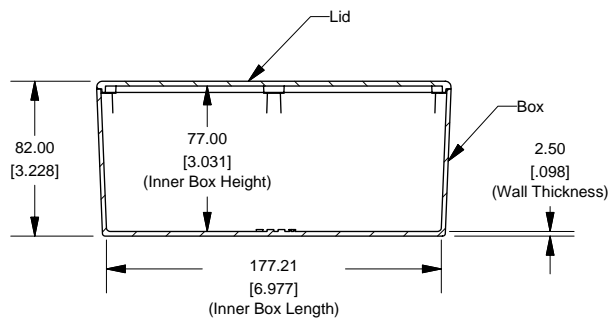

Top View Looking Inside Box

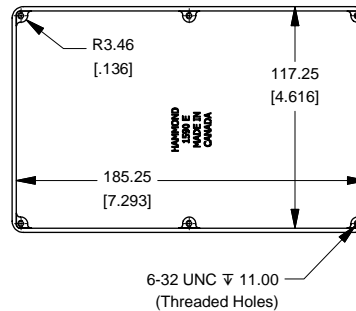

Lid

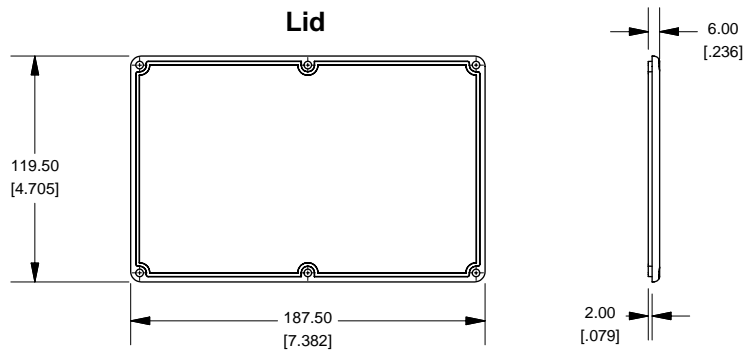

NOTE
Purchased assembly includes box, lid and 4 cover screws.
Box and lid are made from Diecast Aluminum Alloy (alloy type 360.1).

PART NUMBERS	
1590E Enclosure	
Unfinished	1590E
Black Textured Powder Paint	1590EBK
1590E Liquid Resistant Enclosure (Silicon Factory Installed Gasket)	
Unfinished	1590WE
Black Textured Powder Paint	1590WEBK
ACCESSORIES	
Unfinished	
Cover Screws (Pkg 100) [6-32 x 1/2" Nickel Plated Screws]	1590MS100
Black Textured Powder Paint	
Cover Screws (Pkg 50) [6-32 x 1/2" Stainless Steel Black Screws]	1590MS50BK

