

SECTION A-A

REV.	MODIFICATION.	DATE	DRN
A	NEW DWG	221295	
B	SCN99-027	290499	JPM
C	SCN01-110	251001	JPM
D	ECN#802	160604	NJB
E	ECR05-041	310305	NBr
06	ECR06-032	180106	OW
07	ECR06-035	260106	OW
08	ECN07-050	270207	OW

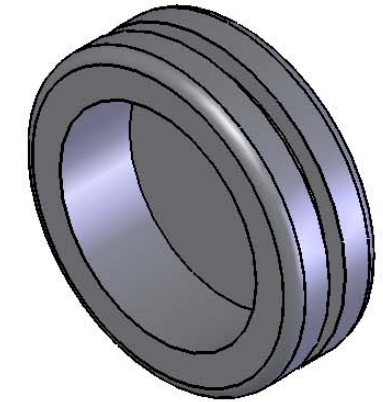

NOTES

- 1a) METRIC PRIMARY UNITS:mm
- 1b) IMPERIAL SECONDARY UNITS: [inches]
- 2) PARTS ALSO AVAILABLE IN V0 RATED MATERIAL (RMS-263) BY SPECIAL ORDER.

INFORMATION CONTAINED IN THIS DOCUMENT IS CONFIDENTIAL TO RICHCO INTERNATIONAL Co. Ltd. AND MAY NOT BE DISCLOSED OR REPRODUCED IN WHOLE OR PART WITHOUT THEIR WRITTEN CONSENT.



GENERAL TOLERANCE:
FOR REFERENCE ONLY ±0.5 [.02]
UNLESS OTHERWISE STATED
ANGULAR ±1°

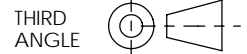

MATERIAL: TPE (RMS-262)		COLOUR: BLACK	
DESCRIPTION: DIAPHRAGM GROMMET, BLIND		PART No: SEE TABLE	
DRG No: 770-0001	NPR No: N/A	SHEET SIZE A4	
DRN OW	DATE 31/03/05	CHKD NBr	DATE 31/03/05
SCALE NTS		SHEET No. 1 OF 1	

DGB-2.5	9.4 [.37]	6.4 [.252]	4.1 [.161]	0.8 [.032]	3.6 [.142]
DGB-4	12.7 [.5]	9.9 [.39]	6.4 [.252]	1.5 [.06]	6.6 [.26]
DGB-5	15.7 [.62]	12.5 [.49]	9.5 [.374]	1.5 [.06]	6.4 [.252]
DGB-6	17.5 [.689]	11.0 [.433]	8.0 [.315]	1.5 [.06]	8.0 [.315]
DGB-7	19.0 [.75]	16.0 [.63]	11.0 [.433]	1.5 [.06]	8.0 [.315]
DGB-10	25.5 [1.004]	22.0 [.866]	18.4 [.724]	1.5 [.06]	8.0 [.315]
DGB-11	25.5 [1.004]	19.0 [.75]	16.0 [.63]	1.5 [.06]	7.0 [.276]
DGB-13	30.0 [1.2]	25.5 [1.004]	20.5 [.807]	1.5 [.06]	8.0 [.315]
PART NUMBER	"A"	"B"	"C"	"D"	"E"