

Top View of Assembly

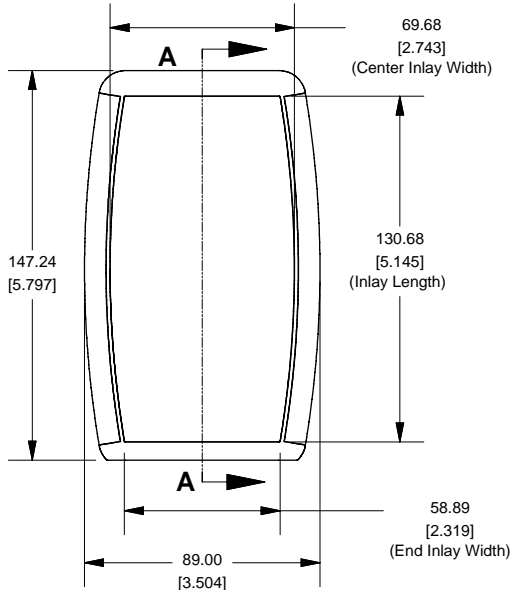

SECTION A-A (Side View Inside Assembly)

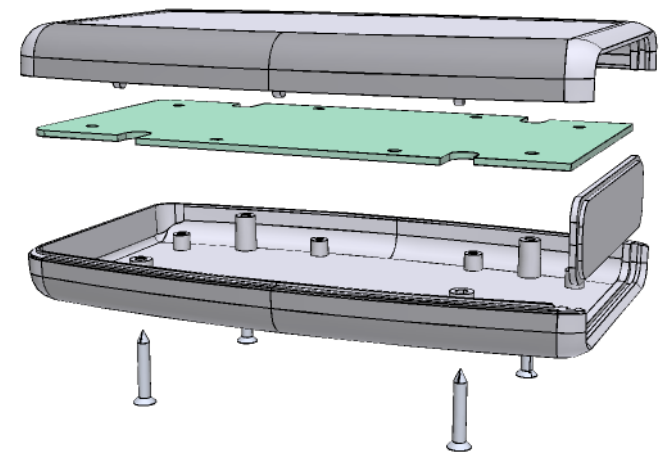
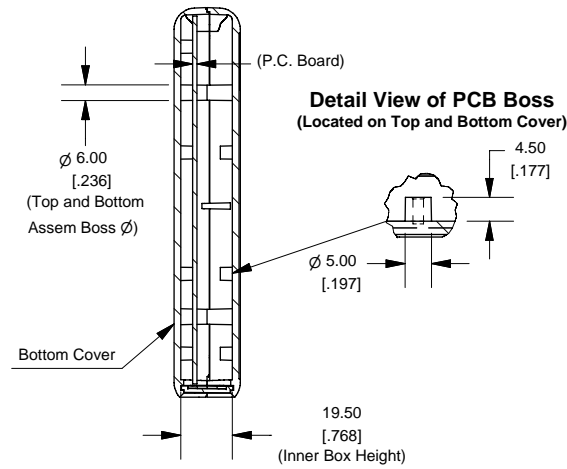

End View of Assembly

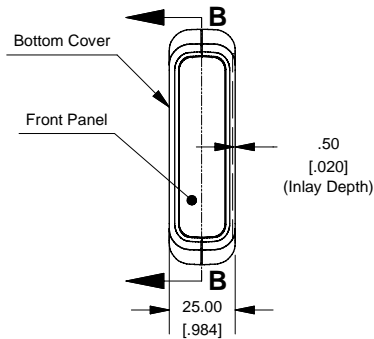

SECTION B-B (Inside of Bottom Cover)

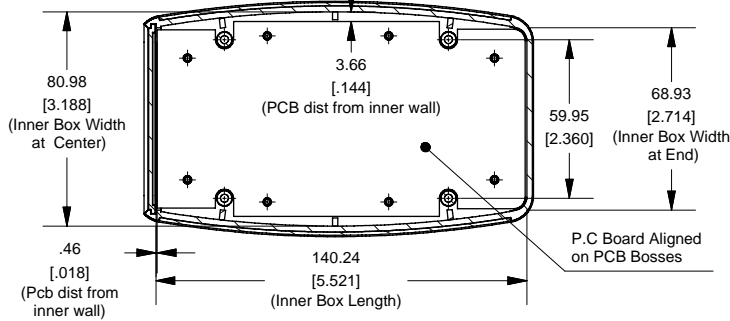

Maximum P.C. Board Size

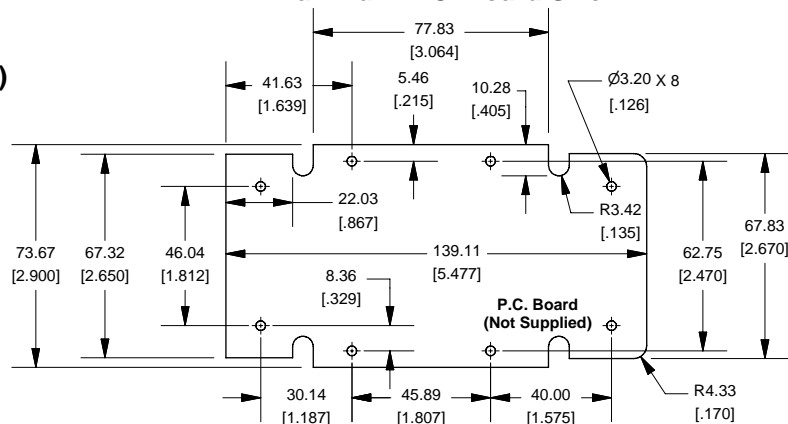

Front/Rear Panel (Dashed Line Indicates Viewing Area)

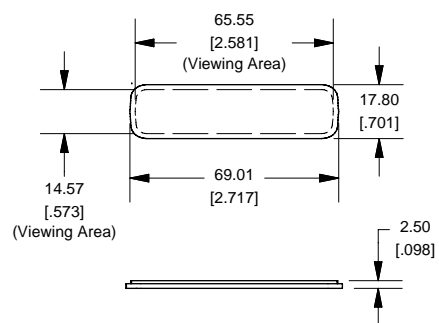

Enclosures can be Factory Modified (Milling, Drilling, Printing etc.)
 Solid models of this enclosure available in STEP or IGES.
 Contact Factory mjm@hammondmgf.com

NOTE	
Enclosure molded from GP ABS (UL94-HB) plastic.	
Purchased assembly includes top and bottom cover, front plastic panel and 4 cover screws.	

PART NUMBERS	
1553D Enclosure	
Black Enclosure/Grey Over-mold	1553DBK
Grey Enclosure/Grey Over-mold	1553DGY
ACCESSORIES	
Cover Screws (Pkg 100) [#4 x 5/8" self-tapping oval head (15.9mm)]	1593MS100 (Silver) 1593MS100BK (Black)
P.C. Board Screws [#4 x 1/4" self-tapping (6.4mm)]	1593ATS50 (Pkg 50) 1593ATS100 (Pkg 100)
Belt or Pocket Clip	1599CLIP (Black) 1599CLIPGY (Grey)

HAMMOND MANUFACTURING™

1553D

www.hammondmgf.com