

2

1

Top View of Assembly

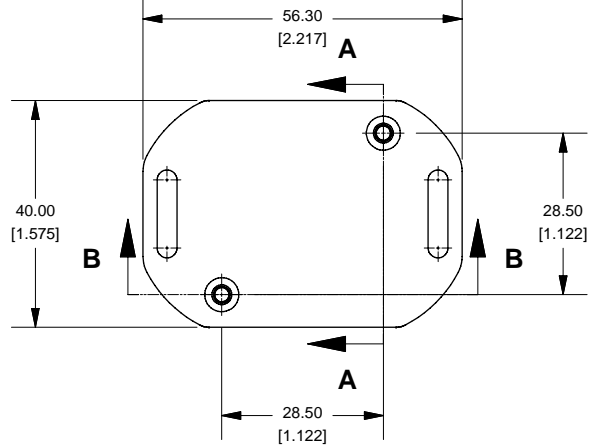

SECTION A-A End View of Assembly

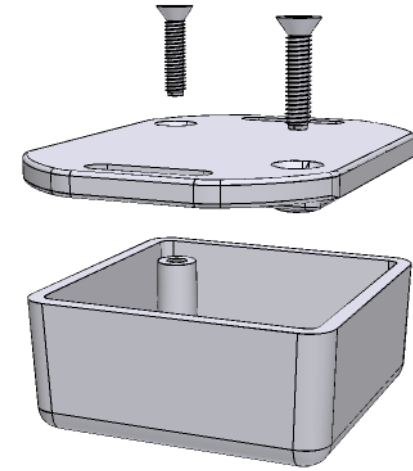
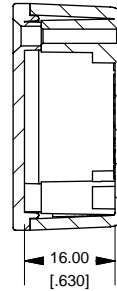

SECTION B-B Side View of Assembly

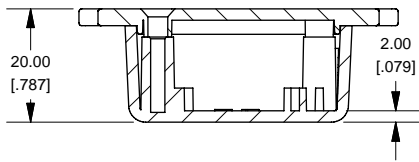

Top View Looking Inside Box

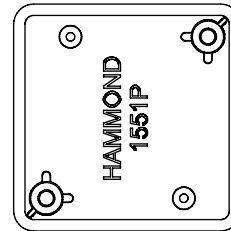

SECTION C-C Boss Heights

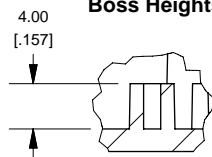

Lid

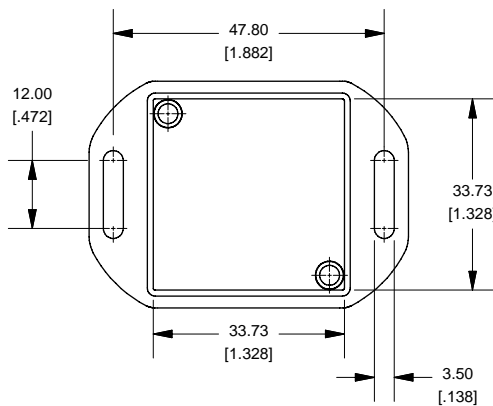

Maximum P.C. Board Size

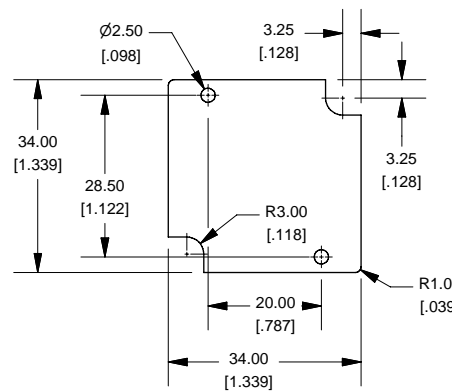

NOTE

Purchased assembly includes lid and box made from GP ABS material and cover screws.

1551PFL

1551PFL Enclosure

Black Enclosure - RAL 9011 - UL94 - HB	1551PFLBK
Gray Enclosure - RAL 7035 - UL94 - HB	1551PFLGY
Translucent Blue - UL94 - HB	1551PFLTBU

ACCESSORIES

Recommended Screw Torque: 15-20 ozf.in (10-15 cN.m)

Black Enclosure Cover Screws (Pkg 100) X 1/2" Self Tapping	#4	1591TS100BK
Grey Enclosure Cover Screws (Pkg 100) X 1/2" Self Tapping	#4	1591TS100
P.C. Board Screws (Pkg 100) #2 x 3/16" Self Tapping		1551ATS100



HAMMOND MANUFACTURING™

1551PFL

www.hammondmfg.com

2

1