

Top View of Assembly

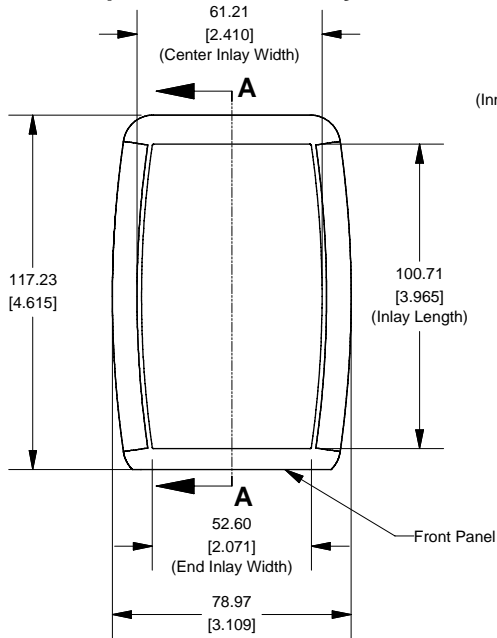

SECTION A-A (Side View Inside Assembly)

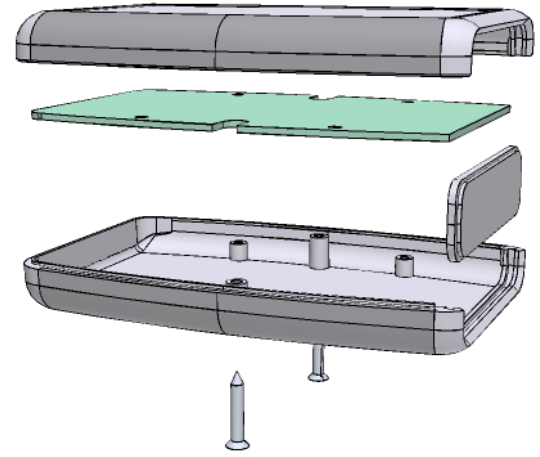
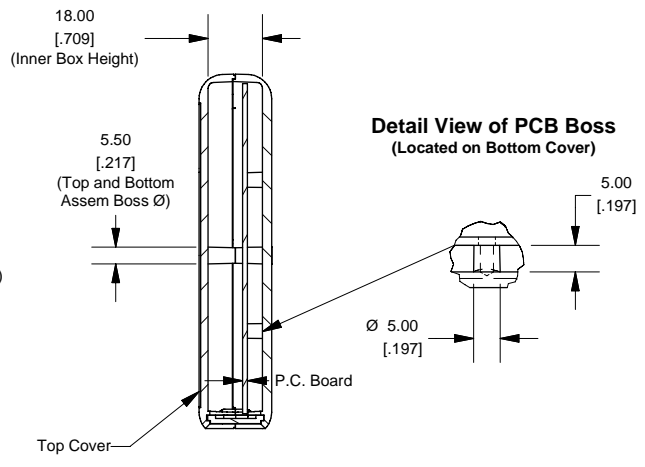

End View of Assembly

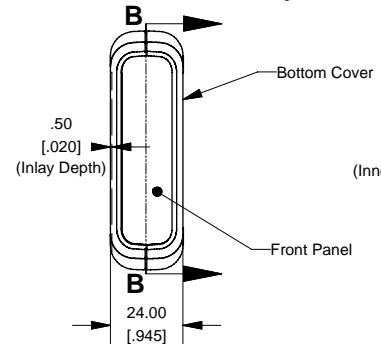

SECTION B-B (Inside of Bottom Cover)

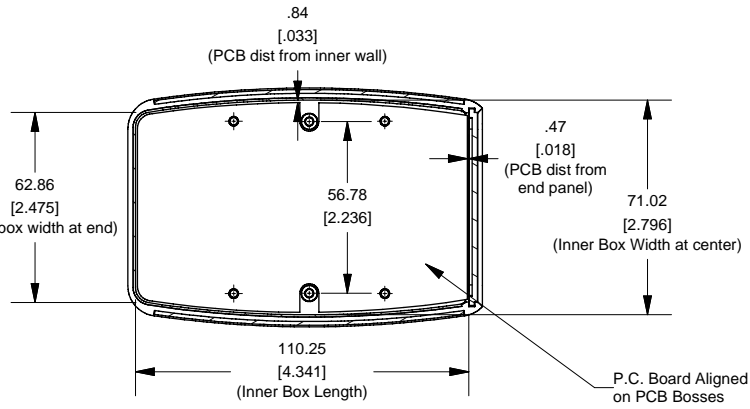

Enclosures can be Factory Modified (Milling, Drilling, Printing etc.)
 Solid models of this enclosure available in STEP or IGES.
 Contact Factory mjm@hammondmfg.com

NOTE	
Enclosure molded from GP ABS (UL94-HB) plastic.	
Purchased assembly includes top and bottom cover, front plastic panel and 2 cover screws.	

PART NUMBERS

1553B Enclosure	
Black Enclosure/Grey Over-mold	1553BBK
Red Enclosure/Black Over-mold	1553BGY
Translucent Blue Enclosure/Black Over-mold	1553BTBUBK
Yellow Enclosure/Black Over-mold	1553BYLKB
Grey Enclosure/Grey Over-mold	1553BGYBAT

ACCESSORIES

Cover Screws (Pkg 100)	1593MS100 (Silver)
[#4 x 5/8" self-tapping oval head (15.9mm)]	1593MS100BK (Black)
P.C. Board Screws	1593ATS50 (Pkg 50)
[#4 x 1/4" self-tapping (6.4mm)]	1593ATS100 (Pkg 100)
Belt or Pocket Clip	1599CLIP (Black) 1599CLIPGY (Grey)

Front/Rear Panel (Dashed Line Indicates Viewing Area)

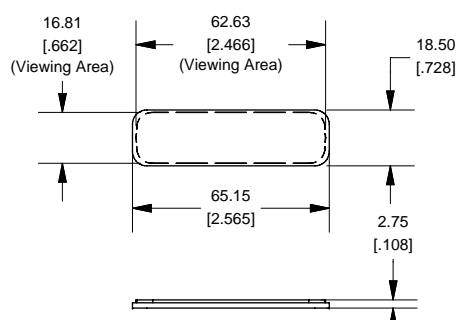

Maximum P.C. Board Size

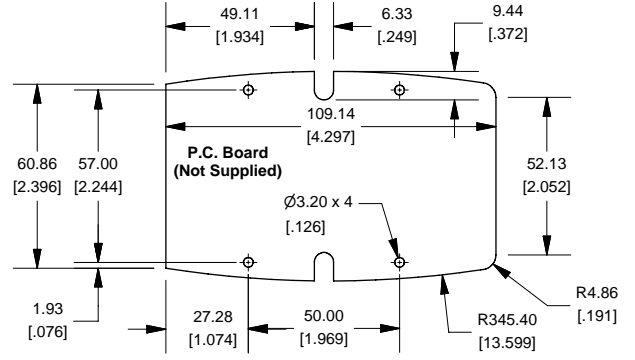

HAMMOND MANUFACTURING™
1553B
www.hammondmfg.com