

1591GFL Enclosure

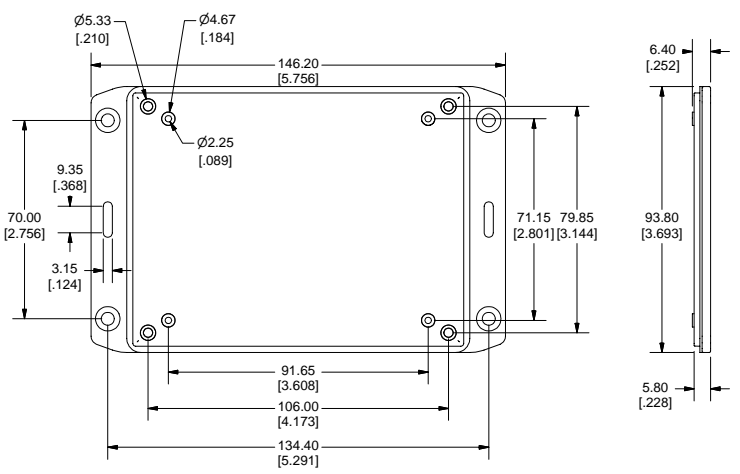

Note:
 Enclosures can be Factory Modified (Milling, Drilling, Printing etc.)
 Solid models of this enclosure available in STEP or IGES Format.
 Contact Factory mjm@hammondmfg.com

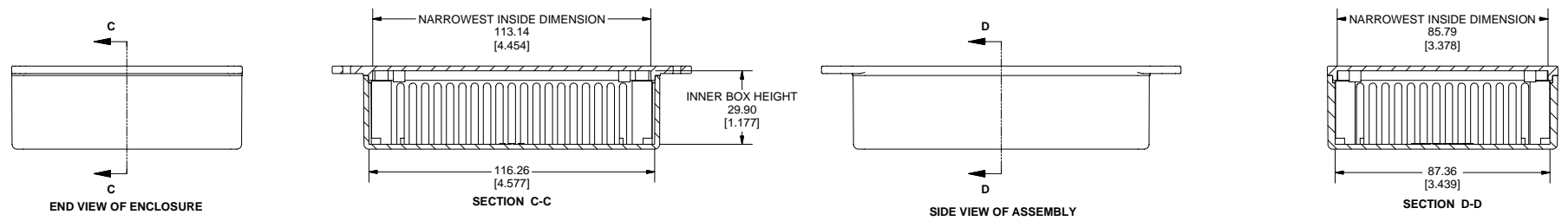
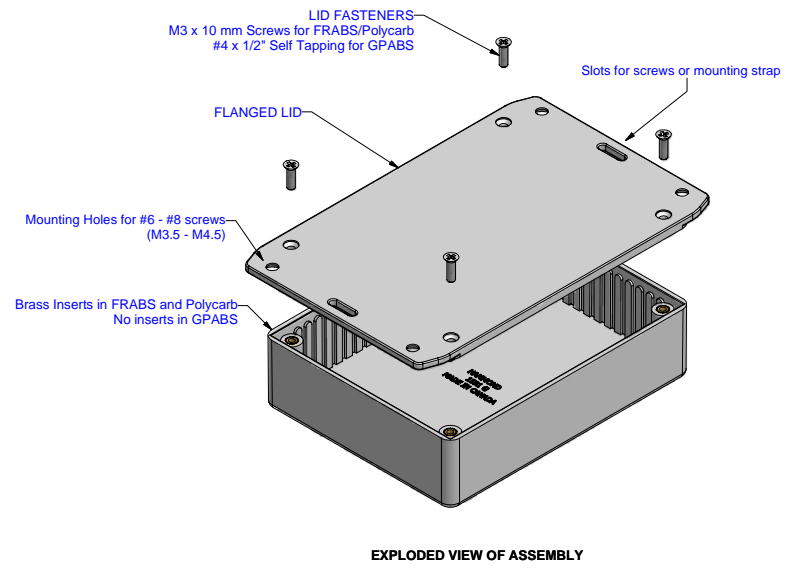
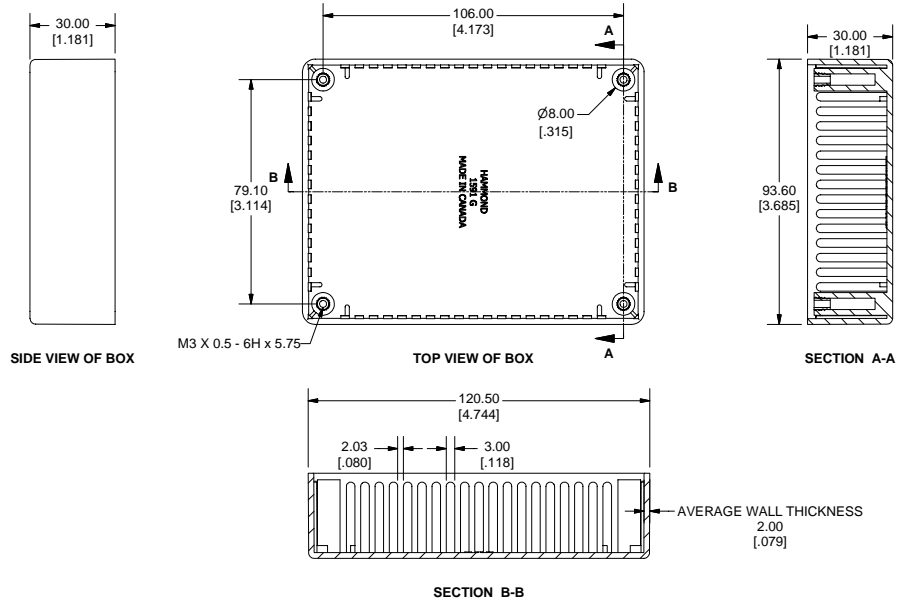

PART NUMBERS		
1591G Flanged Lid Enclosures		
Material	Colour	Part Number
FRABS UL94	Black	1591GFLBK
- V0	Grey	1591GFLGY
Accessories		
Description	Part Number	
Used with ABS Enclosures	PC Board Card Adapters	See Accessories Section
	Replacement Screws, Flat Head Phillips Nickel Plated Pack of 100,	1591MS100
	Recommended Torque on Fasteners (no lubrication)	1591MS100BK (Black)
	M3 - 0.5 x 10mm Screws	30-40 cN*m
	#4 x 0.5 Screws	30-40 cN*m