

SPECIFICATION FOR APPROVAL

| | | | | |
|---|-----------------------------------|------------------|----------------------------------|-------------------|
| CUSTOMER ROSSMANN | CUSTOMER P/N 5344 12-66 | REV. — | SPL. LOT NO. | |
| PART NAME TOROID COIL (RoHS) | 3011I162-LFR | REV. | DATE OF ISSUE 07/13/10 | Q'TY EA |

1. MECHANICAL DIMENSION

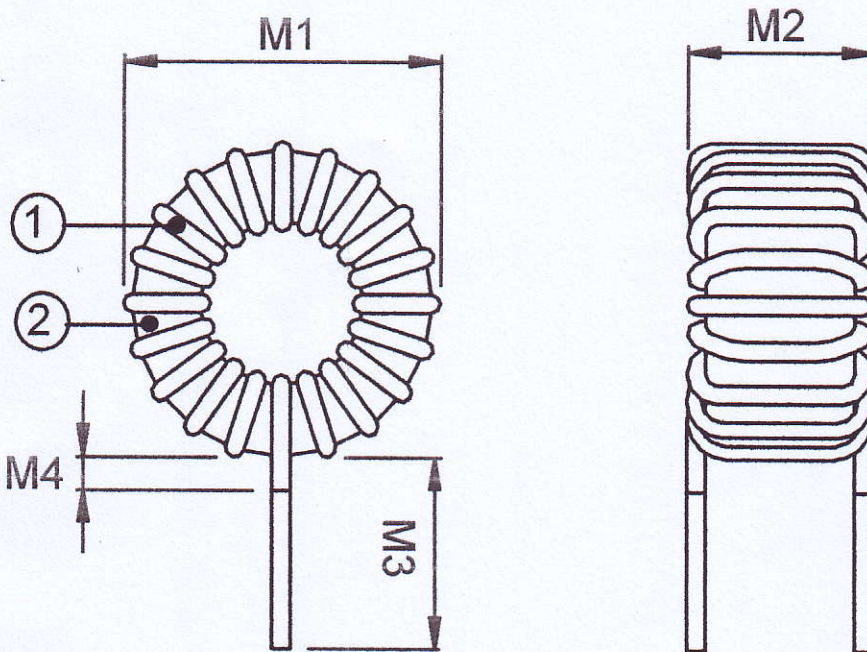

UNIT: mm

| | DIM. | TOL. |
|----|-------|-------|
| M1 | 19.05 | MAX. |
| M2 | 8.89 | MAX. |
| M3 | 12.7 | ±1.27 |
| M4 | 1.5 | MAX. |

2. ELECTRICAL

| | |
|---------------------------------|-----------------------------|
| L(uH) @ 1 KHz ±25% | DCR (OHM) MAX. |
| 50 | 0.08 |

TEST INSTRUMENT: HP4276A & CH502A

3. WINDING:

WIRE: 0.6 φ mm.

TURN: 31.5 Ts (REF.)

SPECIFICATION FOR APPROVAL

| CUSTOMER | | CUSTOMER P/N | | REV. | SPL. LOT NO. | |
|-----------------------|---------|--|--------------|---|---|--------------------|
| ROSSMANN | | 5344 12-66 | | — | | |
| PART NAME | | | REV. | DATE OF ISSUE | Q'TY | |
| TOROID COIL (RoHS) | | | 3011I162-LFR | | 07/13/10 | EA |
| ITEM | PART | DESCRIPTION | RATING | SUPPLIERS | SGS NO. | UL NO. |
| a | WIRE | SINGLE POLYURETHANE NYLON COATED COPPER WIRE.(UEY) | 130°C | JUNG SHING WIRE CO., LTD. OR EQUIV. | KA/2009/B1304 CE/2009/11669B | E174837 E201757 |
| b | CORE | IRON | | SAMSON ENTERPRISES LIMITED. CURIE INDUSTRIAL CO., LTD. OR EQUIV. | CANEC0805455703 KA/2008/B0461A-02 KA/2008/B0464A-02 CE/2009/12032 CE/2009/12048 | |
| c | VARNISH | 2820 8110 TS-1001 | | SHENZHEN KAIWEISI CHEMICAL CO., LTD. TESH CHEN ENTERPRISE CO., LTD. OR EQUIV. | CANEC0903560901 CE/2009/43378A | |
| d | SOLDER | Pb FREE (Sn96.5% , Ag3% , Cu 0.5%) | | NISHIMURA CHEMITECH CO., LTD. SOLNET MATEL INDUSTRY CO., LTD. OR EQUIV. | CE/2009/21432 CE/2009/20602 | |
| | | | | | | |
| | | | | | | |
| | | | | | | |
| | | | | | | |
| | | | | | | |