

FOR ENGINEERING DRAWING SEE SIDE 2

*SUPPLIED WITH KIT ONLY

MODEL	1 TOP COVER	2 BOTTOM COVER	3 PANEL BLANK	4 FEET	5 SCREW
LH84-130	71574-01	71575-01	71884-03	60221-01	60227-06
LH84-200	71574-01	72284-01	71884-07	60221-01	60227-11

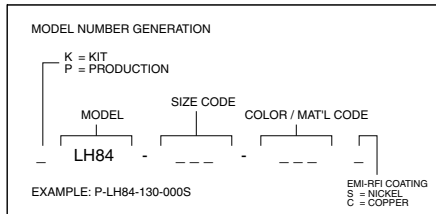

COLOR / MATL CODE		
COLOR	94HB	94VO
BLACK	000	028
*GREY	001	024
*TAN	002	025
P.C.BONE	039	060

*SEE FACTORY FOR AVAILABILITY

PACNTEC®

LH84-130 & LH84-200

1-610-361-4200

SIDE 1

71912-00 REV D 6/96

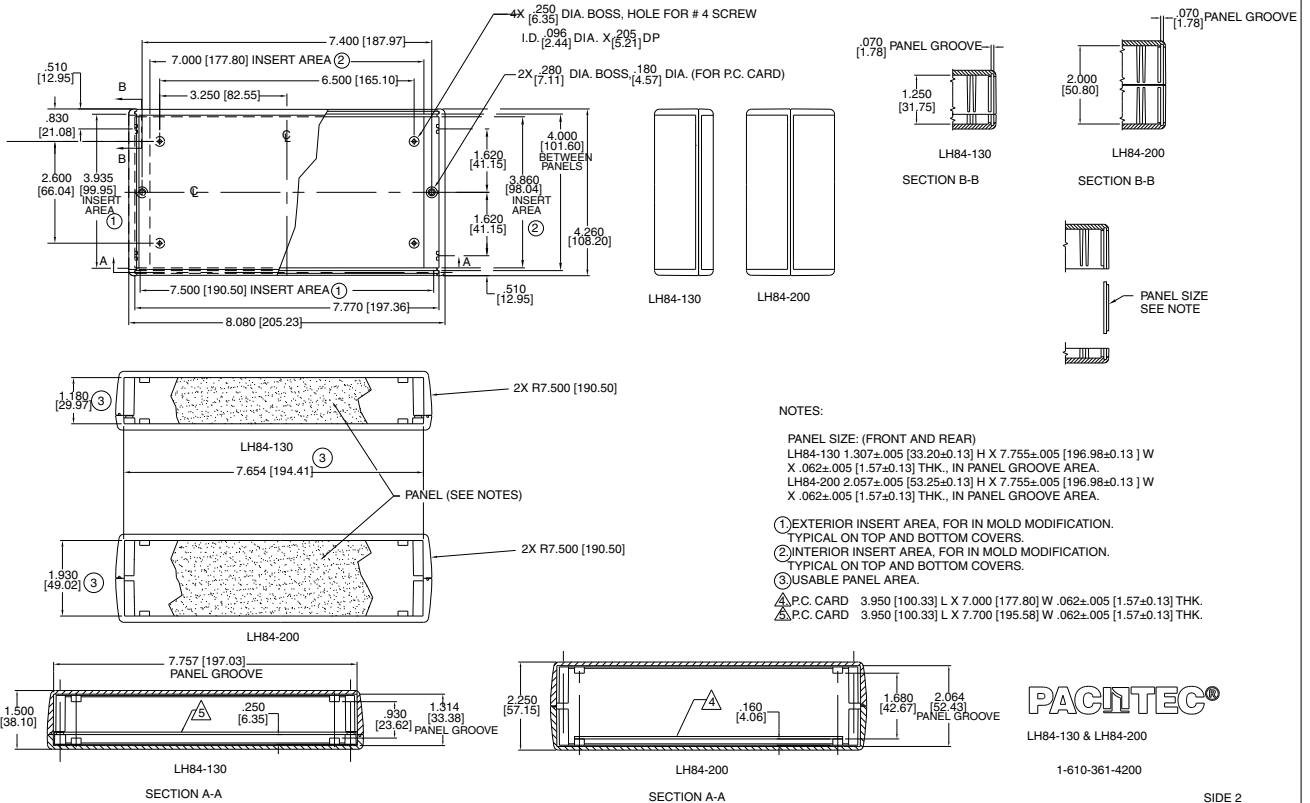

71912-00 REV D 6/96

SIDE 2