

Top View of Assembly

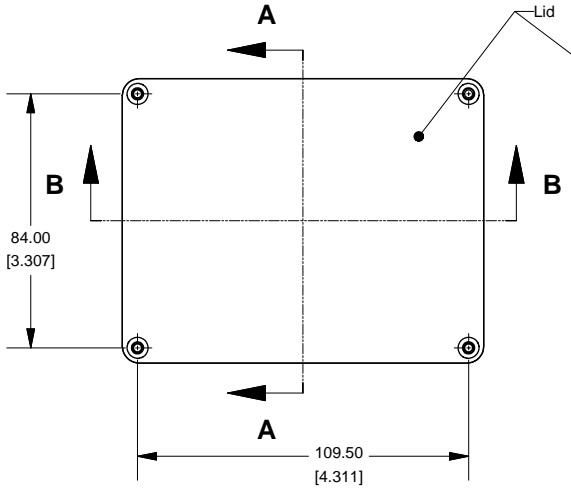

SECTION A-A
End View of Assembly

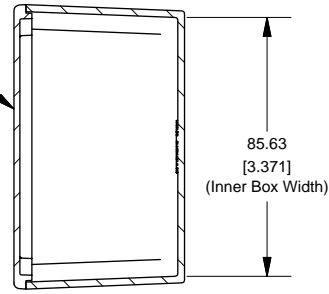

Series 1590C

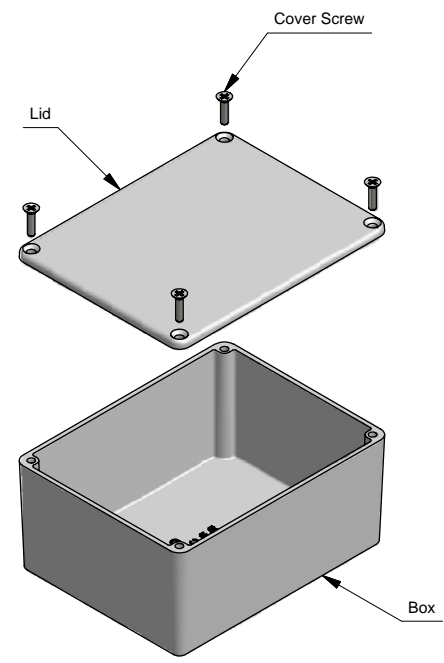

Top View Looking Inside Box

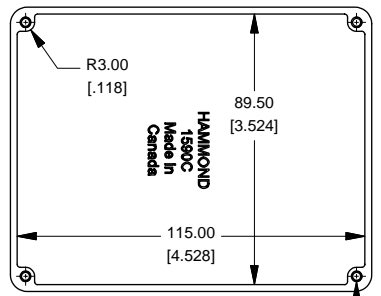

SECTION B-B
Side View of Assembly

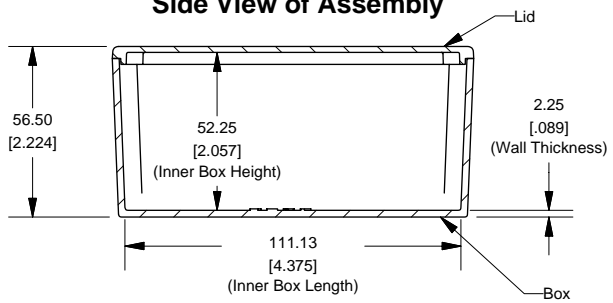

Lid

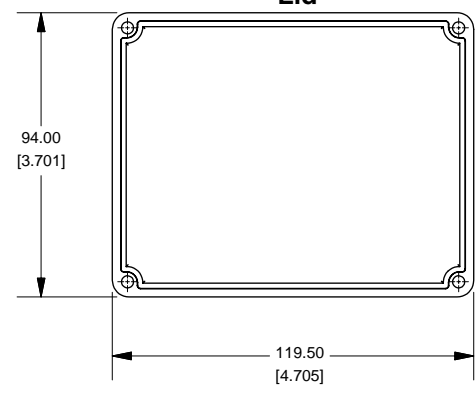

6-32 UNC - 2B ∇ 11.00
 ∇ ϕ 3.50 ∇ 3.00
 (Threaded Holes)

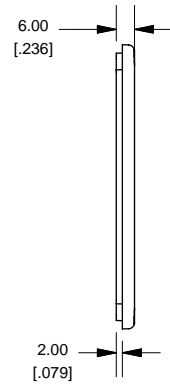

NOTE
 Purchased assembly includes box, lid and 4 cover screws.
 Box and lid are made from Diecast Aluminum Alloy (alloy type 360.1).

PART NUMBERS	
1590C Enclosure	
Unfinished	1590C
Black Textured Powder Paint	1590CBK
1590C Liquid Resistant Enclosure (Silicon Factory Installed Gasket)	
Unfinished	1590WC
Black Textured Powder Paint	1590WCBK
ACCESSORIES	
Unfinished	
Cover Screws (Pkg 100)	1590MS100
[6-32 x 1/2" Nickel Plated Screws]	
Black Textured Powder Paint	
Cover Screws (Pkg 50)	1590MS50BK
[6-32 x 1/2" Stainless Steel Black Screws]	



www.hammondmfg.com