

# UC-TYPE

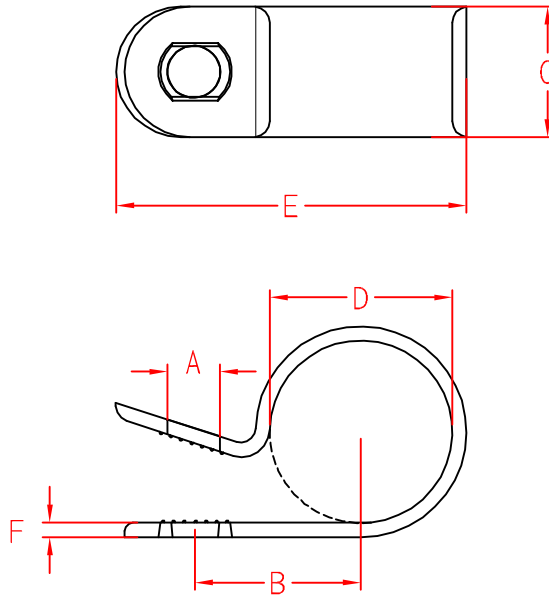

Item No.	A	B	C	D	E	F	Packing
UC-0	4.8±0.25	8.0±0.25	9.6±0.25	3.3±0.25	16.9±0.35	1.2±0.25	100 pcs
UC-0.5	4.8±0.25	9.2±0.25	9.6±0.25	5.3±0.25	18.5±0.35	1.2±0.25	
UC-1	5.1±0.25	10.4±0.35	10.1±0.35	6.8±0.25	20.0±0.50	1.2±0.25	
UC-1.5	5.0±0.25	11.2±0.35	10.0±0.35	8.4±0.25	22.6±0.50	1.2±0.25	
UC-2	5.0±0.25	12.5±0.35	12.3±0.35	10.8±0.35	26.6±0.50	1.4±0.25	
UC-3	5.0±0.25	14.8±0.35	12.2±0.35	13.7±0.35	30.3±0.50	1.4±0.25	
UC-4	5.0±0.25	15.8±0.35	12.4±0.35	17.4±0.35	32.6±0.50	1.4±0.25	
UC-5	4.8±0.25	18.0±0.35	11.8±0.35	19.9±0.35	37.3±0.50	1.4±0.25	
UC-6	5.0±0.25	21.0±0.50	12.0±0.35	27.2±0.50	43.4±1.00	1.4±0.25	
UC-6.5	4.8±0.25	26.0±0.50	12.6±0.35	30.6±0.50	51.5±1.00	1.7±0.25	
UC-7	4.7±0.25	26.0±0.50	12.0±0.35	33.8±0.50	52.3±1.00	1.6±0.25	
UC-9	4.8±0.25	27.8±0.50	12.5±0.35	41.9±1.00	58.3±1.00	1.5±0.25	

MATERIAL: UL 94V-2  
 NYLON 66

ITEM NO. UC-TYPE

SCALE

FINISH

NAME

CABLE CLAMP



(. .)

TOLERANCE AS FIGURE



06-16-2009  
 DATE

REVISIONS K001

R.NO.

