



2-Piece Fixing Ties for Edges, twistable

- CBT30MR for max. bundle diameter 32.0 mm, rotatable 360 °
- CBTO50R for max. bundle diameter 47.0 mm, rotatable 90 °
- CBTO50RStud5 for max. bundle diameter 47.0 mm, rotatable 90 °, for parallel routing

Features and Benefits

With the Edge Clip family the bundled cables can be located either above or to the side of a fixing. In all two piece mounting ties, the edge clip moves freely along the tie. This allows the head of the tie to be rotated during mounting for installation in the ideal position.

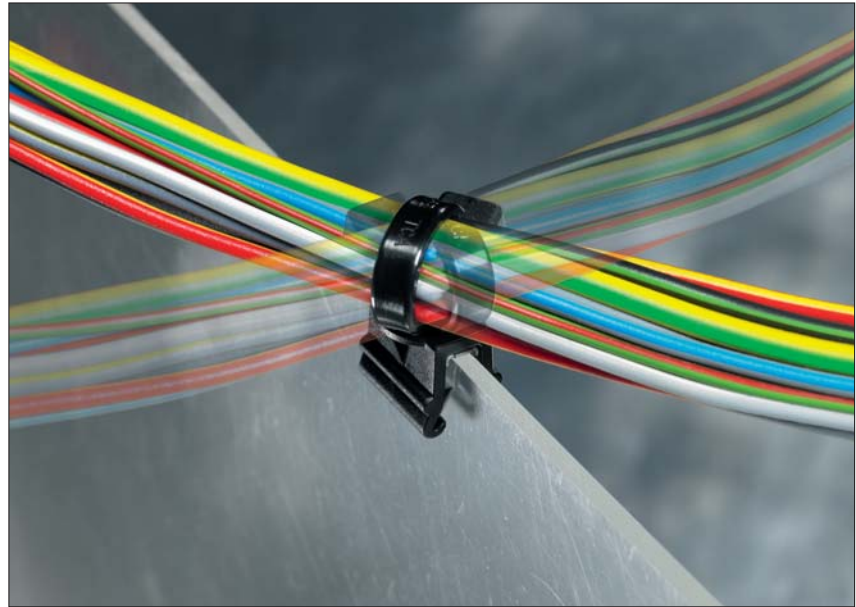

EdgeClip CBTO50R, rotatable 90°.

Material Data	
Material	Polyamide 6.6 Heat Stabilised (PA66HS)
Operating Temperature	-40 °C to +105 °C Continuous, (+145 °C for 500 h)
Flammability	UL94 V2



Material Data	
Material	Polyacetal (POM)
Operating Temperature	-40 °C to +90 °C Continuous, (+110 °C for 500 h)
Flammability	UL94 HB

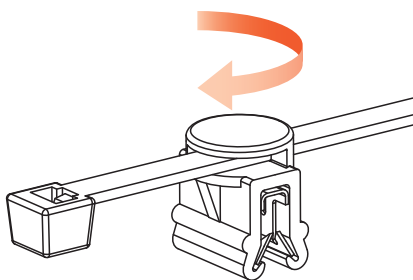

CBTO50R - the bundle can run above an edge

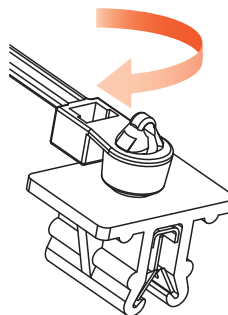

EdgeClip CBT30MR, rotatable 360°

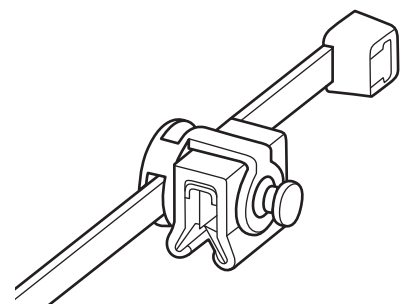

CBTO50RSTUD5

Technical Table

Article-No.	Type	Length (L)	Width (W)	Bundle Ø max.	Min. Tensile strength for ties (N)	Material Cable Tie	Material Foot Part	Panel Thickness max.	Application Tool
156-00049	CBT30MR	160	3.5	32.0	135	PA66HS	POM	2.5	1-3, 5
156-01601	CBTO50R	200	4.6	47.0	225	PA66HS	PA66HIRHS	3.0	1-3, 5
156-00380	CBTO50RSTUD5	200	4.6	50.0	225	PA66HS	PA66HIRHS	3.0	1-3, 5

All dimensions in mm. Subject to technical changes.