

Data sheet | Item number: 756-1501/060-020

System bus/trailing cable, straight; 2 m; fitted on one end; B-coded; M12 socket, straight; one free cable end

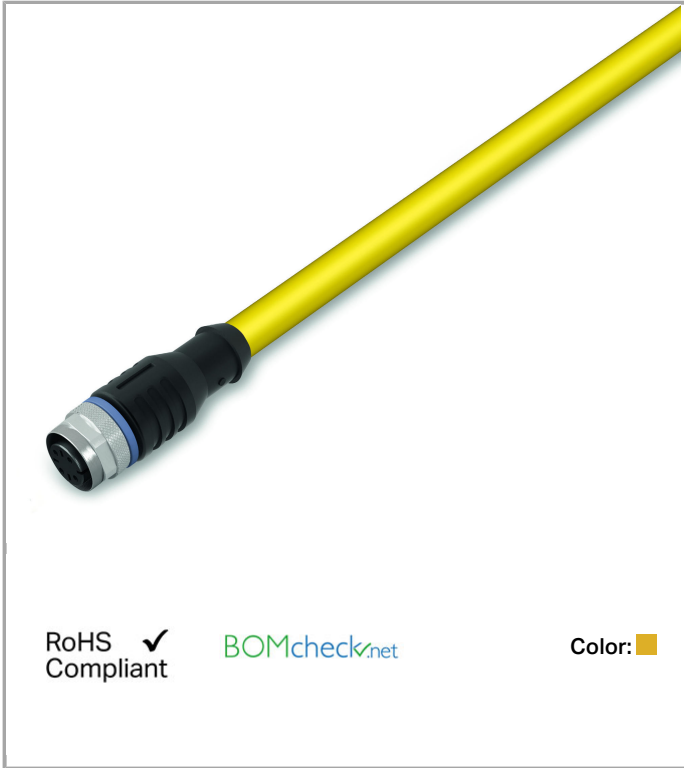

[www.wago.com/756-1501/060-020](http://www.wago.com/756-1501/060-020)



RoHS  
Compliant ✓

BOMcheck.net

Color: ■

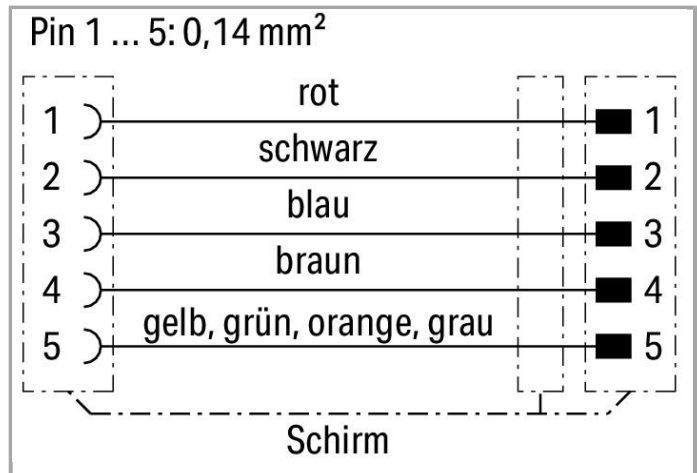
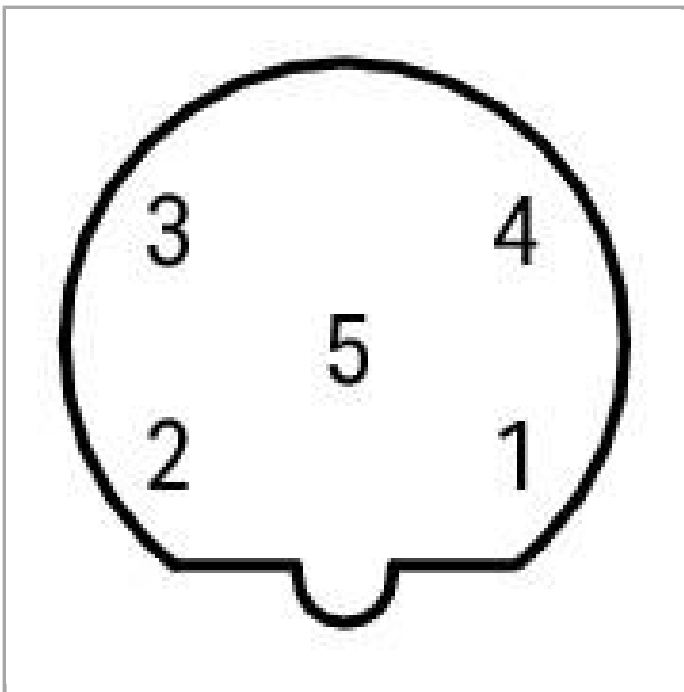
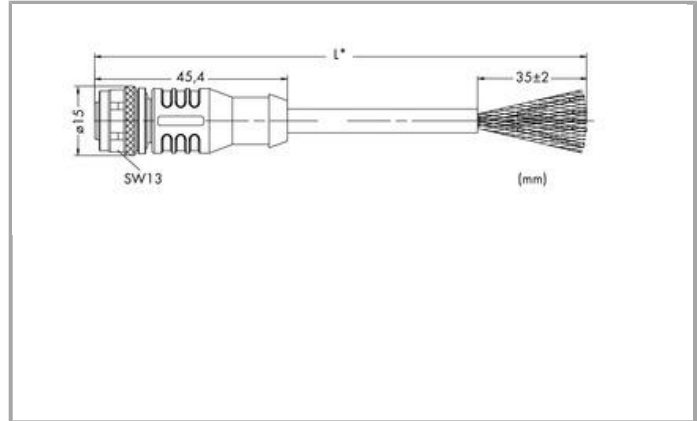

Item description



## Short description:

- PUR, halogen-free
- Suitable for drag chains
- Silicon- and CFC-free
- Good resistance to microbes, hydrolysis, oil, chemicals and UV radiation. Good chemical resistance.

## Data

## Technical Data

Connection type	M12 socket - free end
No. of poles	5
Leitungsanschlussrichtung zur Steckrichtung	0°
Steckgesichtskodierung Leitung/Adapter 1 1	B coded
Cable length	2 m
Operating voltage	60 V
Operating current	4 A
Rated surge voltage	1,5 kV gemäß IEC 61076-2-101
Contact resistance	10 MΩ
Isolationswiderstand	5000 MΩ
Resistance of conductor	≤ 130 Ω/km

## Mechanical data

bending radius	min. 5 x cable Ø
Bending cycles	5
Schleppkettentauglichkeit	yes
Durchmesser der Mantelleitung	6.8 mm
Bauartkurzzeichen	KS-6Y3GC11Y 4x2xAWG26/19 geschirmt
Screening	tinned copper braid, optical coverage approx. 90 %
Conductor design	Bare copper wire, 26/19 AWG
Leiterisolierung	FEP, Ader-Ø max. 1,0 mm
Housing material	TPU/TPU, black (~ RAL 9005)
Contact material	CuZn
Contact plating	CuNi/Au
Materialeigenschaften der Anschlüsse	Hexagon knurled nut: CuZn; Knurled nut surface: nickel-plated; Sealing ring: FPM (Viton)
Mating cycles	100
Tightening torque	1 Nm
Weight	9.999 g
Color	yellow



## Environmental Requirements

Umgebungstemperatur (Betrieb) bewegt	0 ... +50 °C
Umgebungstemperatur (Betrieb) ruhend	-30 ... +85 °C
Degree of protection	IP67
Degree of pollution (5)	3/2 per IEC 60664-1

## Commercial data

Country of origin	DE
GTIN	4050821131212
Customs Tariff No.	85444290900

## Downloads

### Documentation

#### System Description

I/O-SYSTEM – <i>SPEEDWAY</i> , General Product Information	Jun 6, 2017	1.1 MB	<a href="#">Download</a>
--	-------------	--------	--------------------------

Subject to changes.