

# Signal conditioner - MINI MCR-SL-I-U-4 - 2813538

Please be informed that the data shown in this PDF Document is generated from our Online Catalog. Please find the complete data in the user's documentation. Our General Terms of Use for Downloads are valid (<http://download.phoenixcontact.com>)



MCR 3-way isolating amplifier, for electrical isolation of analog signals, with screw connection, input signal: 4 mA ... 20 mA, output signal: 0 A ... 10 V

## Product Features

- Power supply possible via the foot element (T-connector)
- Low power consumption
- Entry-level alternative to configurable signal conditioners
- Highly-compact isolating amplifier for electrical isolation, conversion, amplification, and filtering of standard analog signals
- 3-way isolation
- Fixed signal combinations



**Ex n**

## Key commercial data

package_quantity	1
GTIN	4046356100632

## Technical data

Note:

Utilization restriction	EMC: class A product, see manufacturer's declaration in the download area
-------------------------	---

## Dimensions

Width	6.2 mm
Height	93.1 mm
Depth	102.5 mm

## Ambient conditions

Ambient temperature (operation)	-20 °C ... 65 °C
Ambient temperature (storage/transport)	-40 °C ... 85 °C
Degree of protection	IP20

## Input data

Configurable/programmable	No
Current input signal	4 mA ... 20 mA
Max. input current	50 mA

# Signal conditioner - MINI MCR-SL-I-U-4 - 2813538

## Technical data

### Input data

<b>Input resistance current input</b>	approx. 50 Ω
---------------------------------------	--------------

### Output data

<b>Configurable/programmable</b>	No
<b>Voltage output signal</b>	0 V ... 10 V
<b>Max. output voltage</b>	12.5 V
<b>Short-circuit current</b>	approx. 2 mA
<b>Load/output load voltage output</b>	≥ 10 kΩ

### Power supply

<b>Nominal supply voltage</b>	24 V DC
<b>Supply voltage range</b>	19.2 V DC ... 30 V DC (The T connector (ME 6,2 TBUS-2 1,5/5-ST-3,81 GN, Order No. 2869728) can be used to bridge the supply voltage. It can be snapped onto a 35 mm DIN rail according to EN 60715))
<b>Max. current consumption</b>	< 9 mA
<b>Power consumption</b>	< 200 mW

### Connection data

<b>Connection method</b>	Screw connection
<b>Conductor cross section solid min.</b>	0.2 mm <sup>2</sup>
<b>Conductor cross section solid max.</b>	2.5 mm <sup>2</sup>
<b>Conductor cross section stranded min.</b>	0.2 mm <sup>2</sup>
<b>Conductor cross section stranded max.</b>	2.5 mm <sup>2</sup>
<b>Conductor cross section AWG/kcmil min.</b>	26
<b>Conductor cross section AWG/kcmil max</b>	12
<b>Stripping length</b>	12 mm
<b>Screw thread</b>	M3

### General

<b>Maximum transmission error</b>	≤ 0.1 % (of final value)
<b>Maximum temperature coefficient</b>	< 0.01 %/K
<b>Temperature coefficient, typical</b>	< 0.002 %/K
<b>Limit frequency (3 dB)</b>	approx. 100 Hz
<b>Step response (10-90%)</b>	approx. 3.5 ms
<b>Electrical isolation</b>	Basic insulation according to EN 61010
<b>Surge voltage category</b>	II
<b>Pollution degree</b>	2
<b>Rated insulation voltage</b>	50 V AC/DC
<b>Test voltage, input/output/supply</b>	1.5 kV (50 Hz, 1 min.)
<b>Electromagnetic compatibility</b>	Conformance with EMC Directive 2004/108/EC
<b>Noise emission</b>	EN 61000-6-4
<b>Noise immunity</b>	EN 61000-6-2 When being exposed to interference, there may be minimal deviations.
<b>Color</b>	green

# Signal conditioner - MINI MCR-SL-I-U-4 - 2813538

## Technical data

### General

<b>Housing material</b>	PBT
<b>Mounting position</b>	Any
<b>Assembly instructions</b>	The T connector can be used to bridge the supply voltage. It can be snapped onto a 35 mm DIN rail according to EN 60715.
<b>Conformance</b>	CE-compliant
<b>ATEX</b>	# II 3 G Ex nA IIC T4 Gc X
<b>UL, USA / Canada</b>	UL 508 Recognized
<b>UL, USA / Canada</b>	Class I, Div. 2, Groups A, B, C, D T5 applied for
<b>GL</b>	GL EMC 2 D

### EMC data

<b>Name</b>	Electromagnetic RF field
<b>Standards/regulations</b>	EN 61000-4-3
<b>Typical deviation from the measuring range final value</b>	5 %
<b>Name</b>	Fast transients (burst)
<b>Standards/regulations</b>	EN 61000-4-4
<b>Typical deviation from the measuring range final value</b>	5 %
<b>Name</b>	Conducted interferences
<b>Standards/regulations</b>	EN 61000-4-6
<b>Typical deviation from the measuring range final value</b>	5 %

## classifications

### eCl@ss

<b>eCl@ss 4.0</b>	27210120
<b>eCl@ss 4.1</b>	27210120
<b>eCl@ss 5.0</b>	27210120
<b>eCl@ss 5.1</b>	27210120
<b>eCl@ss 6.0</b>	27210120
<b>eCl@ss 7.0</b>	27210120
<b>eCl@ss 8.0</b>	27210120

### ETIM

<b>ETIM 2.0</b>	EC001485
<b>ETIM 3.0</b>	EC001485
<b>ETIM 4.0</b>	EC001485
<b>ETIM 5.0</b>	EC001485

### UNSPSC

<b>UNSPSC 6.01</b>	30211506
<b>UNSPSC 7.0901</b>	39121008
<b>UNSPSC 11</b>	39121008
<b>UNSPSC 12.01</b>	39121008
<b>UNSPSC 13.2</b>	39121008

# Signal conditioner - MINI MCR-SL-I-U-4 - 2813538

## approvals

---

ATEX / UL Recognized / cUL Recognized / GL / cULus Recognized /

---

### Approval details

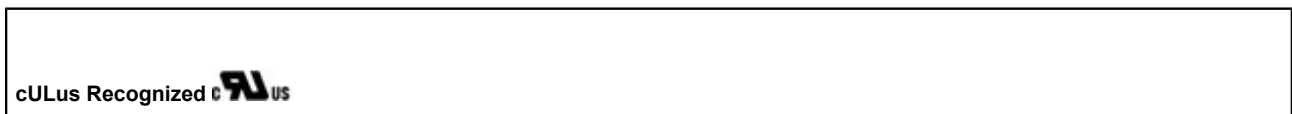
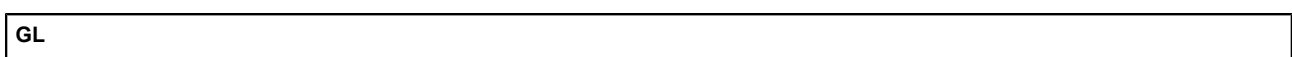
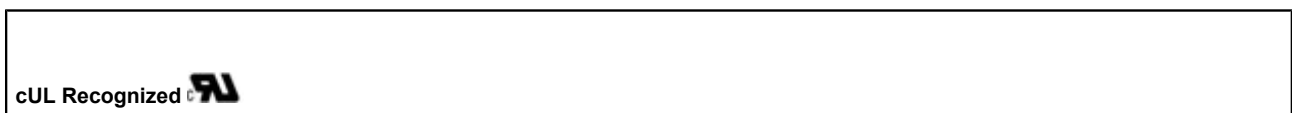
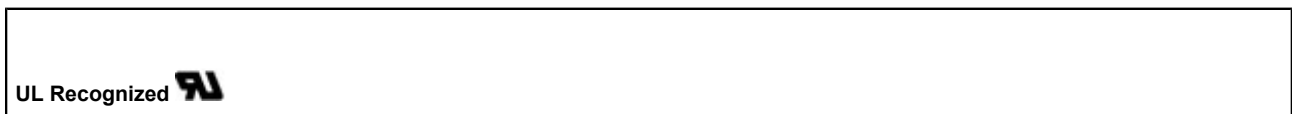
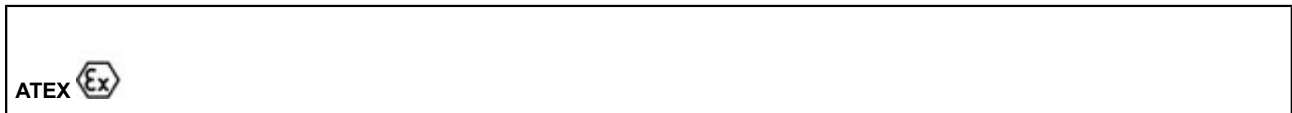

## accessories

### DIN rail connector

ME 6,2 TBUS-2 1,5/5-ST-3,81 GN - 2869728



---

### Power module

MINI MCR-SL-PTB - 2864134



## Signal conditioner - MINI MCR-SL-I-U-4 - 2813538

### accessories

MINI MCR-SL-PTB-SP - 2864147



---

### Power supply

MINI-SYS-PS-100-240AC/24DC/1.5 - 2866983



MINI-PS-100-240AC/24DC/1.5/EX - 2866653



---

### System adapter

MINI MCR-SL-V8-FLK 16-A - 2811268



---

### Marking material

MINI MCR DKL - 2308111



# Signal conditioner - MINI MCR-SL-I-U-4 - 2813538

accessories

MINI MCR-DKL-LABEL - 2810272



## Drawings

Block diagram

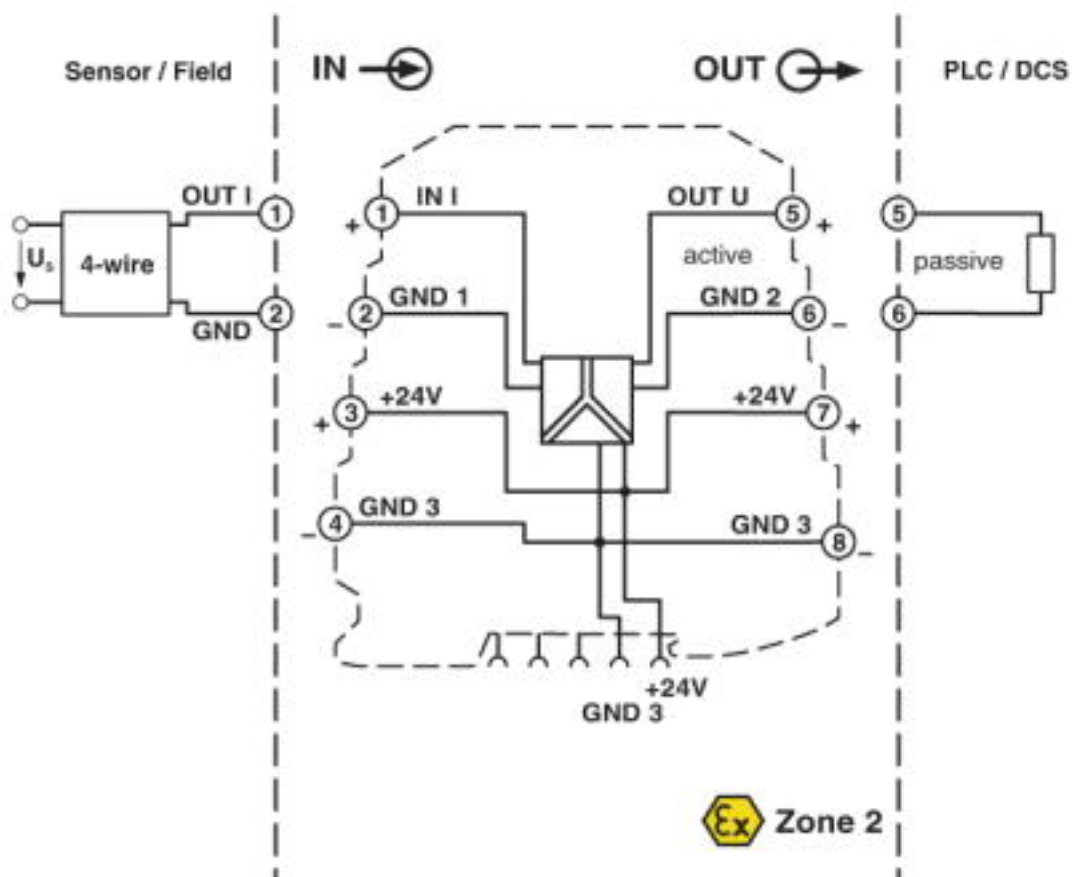

# Signal conditioner - MINI MCR-SL-I-U-4 - 2813538

Dimensioned drawing

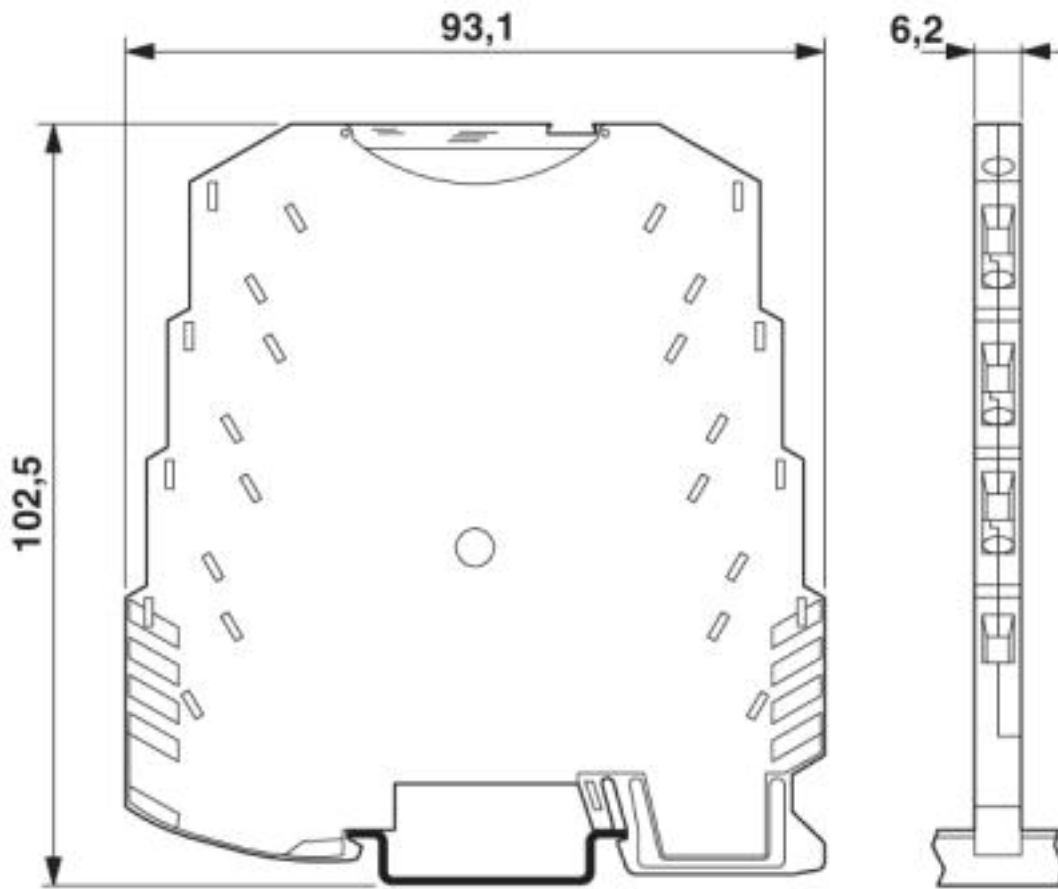

© Phoenix Contact 2013 - all rights reserved  
<http://www.phoenixcontact.com>