



Operating instructions

GB

ERSA soldering station

i-CON[®] 1



1. Introduction	4
1.1 Supply unit	4
2. Technical data	5
3. For your safety	6
3.1 Pictograph and symbol explanations	7
3.2 Intended use	8
4. Transport, storage and disposal	11
5. Commissioning	12
5.1 Before starting operation.....	12
5.2 Switching on for the first time.....	13
6. Functional description	14
6.1 Operation	14
6.2 The Work mode	15
6.2.1 Software version	15
6.3 Parameter mode	16
6.3.1 i-Set-Tool.....	18
6.3.2 Set temperature	19
6.3.3 Calibration temperature	19
6.3.4 Tip offset	20
6.3.5 Calibrating the i-CON 1.....	20
6.3.6 Calibration temperature	21
6.3.7 Power Level.....	21
6.3.8 Standby-Time.....	22
6.3.9 Standby-Temperature	22
6.4 Configuration mode.....	23
6.4.1 Temperature window.....	24
6.4.2 Process alarm	24



Contents

6.4.3	Password lock.....	25
6.4.3.1	Setting the password.....	25
6.4.3.2	Changing the password.....	27
6.4.3.3	Input of values without deactivating the password.....	27
6.4.3.4	Forgotten password.....	28
6.4.4	Temperature unit.....	28
6.4.5	Language selection.....	28
6.4.6	Adjustable shut-down function (idle state).....	29
6.4.7	Device number.....	30
6.5	Factory settings ("default").....	31
6.6	Contrast.....	32
6.7	Replacing the soldering tip.....	33
6.7.1	i-Tool.....	33
6.8	Changing the Heating Element.....	35
6.8.1	i-Tool.....	35
6.9	Sensitive components.....	37
7.	Error diagnosis and remedy.....	38
7.1	General Errors.....	38
7.2	Other Errors.....	39
7.3	Continuity check for i-Tool.....	40
7.3.1	Heating element.....	40
7.3.2	Thermocouple.....	40
7.4	Parameter changes not possible.....	40
7.5	Error Messages.....	41
8.	Maintenance.....	43
8.1	Important care jobs.....	43
8.2	Cleaning.....	43
9.	Replacement parts.....	44
9.1	ERSADUR Long-Life Soldering tips (i-Tips).....	46
10.	Warranty.....	51



Operating instructions

1. Introduction

We appreciate your decision to purchase this high-quality soldering station. The i-CON 1 from ERSA is a top-of-the-line micro-processor-controlled soldering station. It is designed for use in industrial production, repairs and in laboratories.

1.1 Supply unit

The use of a microprocessor facilitates operation and sets new standards for the functions available at the soldering station. Five independent tool settings can be made and saved for the connected tool by means of a simple menu guide. With the i-Set Tool (option) it is possible to save these settings. Also you can write back the saved settings into the soldering station. This way, the basic settings can be transferred quickly to several soldering stations.

The i-CON 1 was developed for operation of the i-Tool soldering tool. With its vast variety of functions, the high speed and regulating accuracy this soldering station is most suitable for use in manufacturing processes with high quality requirements.

The soldering station can optionally be delivered with a serial PC-interface. Control signals for the soldering smoke extraction EA110 are also available on this interface.

2. Technical data

Soldering station i-CON 1		
Description	Value	Unit
Mains voltage	220-240	VAC
Mains frequency	50-60	Hz
Fuse (slow-blow)	0,8	A
Mains voltage	110-120	VAC
Mains frequency	50-60	Hz
Fuse (slow-blow)	1,6	A
Secondary voltage	24	VAC
Maximum short-term heating power	150	W
Mean heating power	80	W
Safety class	I	-
Permissible ambient temperature	0-40	°C
Temperature range (stepless)	150-450	°C
	300-842	°F
Temperature regulation (at idle)	< ± 2	°C
Ohmic resistance between soldering tip and ground	< 2	Ohm
Soldering tip to ground leakage voltage	< 2	mV eff
Other		
Control technology	SENSOTRONIC (PID-behaviour)	
Function display	LC-Display, blue	
Supply line 2m, PVC, with connector		
Single-knob control via incremental encoder (i-OP)		
Antistatic surface, especially suited for the application in ESD areas. Option: Serial interface to control the soldering smoke extractor EA110.		
In accordance with MIL-SPEC/ESA-standard		
VDE*, EMV-tested		
Conformity	CE	
Connectable soldering tool: i-Tool		

**A public safety testing company located in Germany.
Similar in operation to its United States counterpart, UL.*

Soldering iron i-Tool		
Description	Value	Unit
Operating Voltage	24	VAC
Maximum heating power	150	W
Mean heating power	80	W
Heating-up time to 350°C / 662°F	approx. 10	sec
Weight (without supply line)	approx. 30	g
Other		
Supply line 1,2 m, highly flexible, heat resistant, antistatic		
Type: Antistatic in accordance to MIL-SPEC/ESA-Standard		
The handle features an integrated identification and standby function.		

3. For your safety

ERSA products are developed, produced and tested in compliance with the basic safety requirements.

Nevertheless, residual risks still exist!

For this reason, please read these operating instructions before you operate your device for the first time. It helps you to become familiar with the device's functions and to use them optimally. Please store these operating instructions at a place which is always accessible to all users!

3.1 Pictograph and symbol explanations

In this instruction manual, pictographs are used as hazard notes.



Special information or orders and prohibitions to prevent personal injury or extensive material damage are supplemented by a pictograph and in the text with hierarchically structured bold words:

Warning! Is used to warn of an imminent danger. Possible consequences can be death or personal injury.

Attention! Is used to warn of a possible dangerous situation. The consequences can be personal injury, material or environmental damage.

Caution! Is used for an application recommendation. The consequences of non-observance can be material damage.

In addition to the hierarchic warning notices described above, we use the following symbols:



This is used to mark text passages which contain explanations, information or tips.

- This sign is used to mark
 - activities which you must carry out, or
 - instructions which must be followed by all means

3.2 Intended use

ERSA heating tools may only be used for the processing of soft solder. In special cases, however, if stated explicitly in the operating manual of the respective tool, some tools can also be used to work plastics. If the tool is not used as intended or tampered with, the manufacturer cannot be held liable for any warranty and liability claims on part of the purchaser.



Attention! Check all components before use. Have any damaged parts repaired by a specialist or the manufacturer. Incorrectly performed repairs represent a risk of accidents for the user. Always use genuine ERSA spare parts for any repairs.



Attention! Heating tools get hot. Before heating up the device, check that the tool insert (e.g. soldering tip, modelling insert, etc.) is correctly connected to the heating tool. Do not allow the hot tool insert to touch your skin, your hair or any materials which are heat-sensitive and flammable. Always work on a base with adequate heat-resistant properties.



Attention! Restrict unauthorised access. Make sure that no unauthorized person, in particular children, can get near heating tool without your permission.



Attention! Danger of fire. Before heating up the heating tool, remove flammable objects, liquids and gases from the area where you will be working with your heating tool. Whenever you take a break from your work, place the heating tool in the holder provided for that purpose. Disconnect your heating tools from the mains after use.

Operating instructions



Attention! Never leave your hot heating tool unattended. Remember that the tool insert needs a certain amount of time to cool down to a safe temperature even after you have switched the device off.



Caution! Keep your workplace tidy. An untidy workplace increases the risk of accidents.



Attention! Lead alloyed solders are toxic. Solders containing lead are toxic if they enter human body. For this reason, it is strictly forbidden to eat, drink or smoke. By equal measure, you should thoroughly wash your hands after working with lead alloyed solder.



Attention! Dispose of waste solder in a responsible fashion. Comply with your local authority's waste disposal regulations when disposing of the by-products of your soldering work.



Attention! Ventilation and extraction. The materials and ancillary substances you use whilst soldering can have a detrimental effect on your health. Make sure there is adequate ventilation or extraction. Comply with the relevant safety data sheets.

Operating instructions



Warning! Protect connection cables. Do not use the connection cable to pull out the plug or as a means of carrying the device. Make sure that connection cables are not exposed to heat and do not come into contact with oil or sharp edges. Damaged connection cables represent a potential cause of fire, short-circuits and electric shocks. Damaged connecting cables can cause fire, short circuits, and electric shock, consequently they must be replaced immediately.



Attention! Take account of ambient conditions. Protect your device against all liquids and moisture. Failure to do this represents a risk of fire or electric shocks.



Caution! Look after your heating tool. Always keep your ERSA product in a safe, dry place out of the reach of children. Pay attention to any maintenance requirements. Check your device at regular intervals. Always use genuine ERSA accessories and spare parts.



Attention! Physically and/or mentally disabled people may only use the soldering station when supervised by trained expert personnel! Children are not allowed to play with the soldering station!

National and international regulations

Comply with national and international regulations governing health and safety at work.

4. Transport, storage and disposal

The i-CON 1 are each delivered in a stable box enclosure. Only use the original packaging for transport and interim storage of the systems. Do not move jerky or drop the i-CON 1. The i-CON 1 must be protected from weather influences such as rain, fog, sea air, etc. If the units will be stored for a longer period of time under humid conditions, then the i-CON 1 must be packed air-tight with desiccating agents in the enclosure. Damages due to improper transport and storage are not covered by the guarantee.



Disposal Notice in accordance with directive 2002/96/EC of the European Parliament and the council of January 27, 2003 on Waste Electrical and Electronic Equipment (WEEE).

Products labelled with the symbol of the crossed out wheeled bin must not be disposed of with unsorted municipal waste. For this purpose, the local authorities have set up collecting points. Please ask your municipality which possibilities are offered for the separate collection of WEEE. This way, you make your contribution to the reuse or other forms of use of WEEE to protect our environment and health.

5. Commissioning

5.1 Before starting operation

Please check the contents of the packaging for completeness. For more information read the chapter on [Spare Parts]! Should the listed components be damaged or incomplete, then please contact your supplier.

The package consists of:

- Electronic station i-CON 1 ①
- Soldering iron i-Tool with soldering tip ②
- Storage stand with drying sponge ③
- Power supply cord
- Operating Instructions



Should the listed components be damaged, then please contact your supplier.

5.2 Switching on for the first time

Be sure to do the following to ensure the safe and long-lasting operation of the soldering tool:

- Check whether the supply voltage matches the value stated on the rating plate.
- Switch off the soldering station with the power switch ①.
- Check the right fit of the soldering tip.
- Connect the soldering tool with the control station ② and put the soldering iron in the holder.
- Connect the power cable to the network supply socket ③.
- Switch on the soldering station ④.

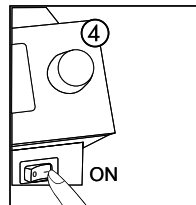
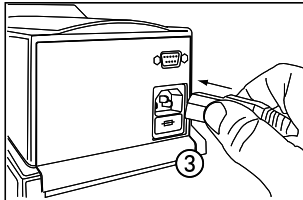
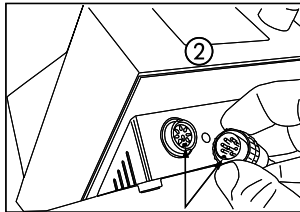
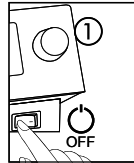

6. Functional description

6.1 Operation

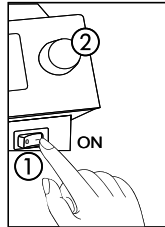

The soldering station is switched on and off by the mains switch on the front side ①.

The soldering station is controlled via a rotary encoder ② with pushbutton function. It is called i-OP. The i-OP makes it possible to select desired functions or to change values. Clockwise turning results in higher values and counter-clockwise turning in lower values. Slow turning effects change in increments of one. Quick turning changes the selected values in increments of 10/50/100 (depending on the corresponding parameter).

The i-OP has an additional pushbutton function. Via this pushbutton function (pushing), the selected parameters and values are confirmed and become effective for the station. All setting steps and measured values are displayed in plain text in a clearly structured display window, which is simply referred to as "Display".

6.2 The Work mode



After the station has been switched on, the switch-on dialog is displayed for approx. 2 seconds. This dialog shows the station name ① and the software version ② of the i-CON 1. The station will then automatically change to work mode with the parameters:

- actual value ③
- set value and possibly standby status ④
- connected soldering tool (i-Tool in our example) ⑤
- password lock active (KEY-symbol) ⑥

In the work mode, the soldering tip temperature can be directly changed by turning the i-OP. Confirm this by pushing the i-OP.



If the password lock is activated, the set value can only be changed via the parameter mode. The password is needed.

6.2.1 Software version

These operating instructions refer to firmware 2.16. For service purposes the number of the software may be of help, you should therefore make a note of it and keep it ready, as you may need it when asked by our Service Department.

6.3 Parameter mode



The following settings can be made in parameter mode:

- Nominal temperature (150-450°C/302-842°F)
- Calibration temperature (-70...+50°C/-126...+90°F)
- Tip offset (Function reserved)
- Energy function (3 stages)
- Standby-Time (0-60min)
- Standby-Temperature (150-300°C).

Please proceed as follows to activate the parameter mode:

- Hold the i-OP depressed for about 2 seconds, or press the i-OP two times quickly in succession.

The parameter mode is now activated. The desired parameter is selected by turning on the i-OP.

For the selected parameter ①, a help text ② is displayed in the last line which gives additional explanations or numerical ranges.

Operating instructions



Proceed as follows in order to change a parameter value:

- Push the i-OP for approx. 2 sec. or two times quickly in succession to open the parameter mode.
- Select the desired parameter by turning the i-OP.
- Press the i-OP to activate the cursor, pressing the i-OP subsequently de-activates the cursor.

If the cursor is activated, the value of the parameter is changed accordingly when the i-OP is turned. If the i-OP is pushed twice, the parameter mode can be called up or left directly.

6.3.1 i-Set-Tool

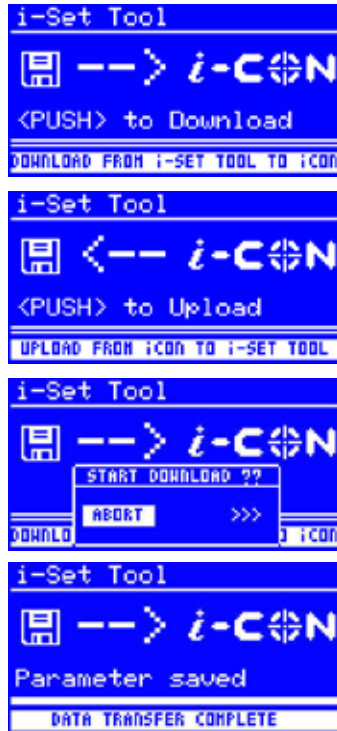

With the i-Set Tool (option) it is possible to save the settings (including password) of the station. Also you can write back the saved settings into the station. This way, the basic settings can be transferred quickly to several soldering stations. Please observe the i-Set Tool's manual for this purpose. How to use the i-Set Tool:

- Disconnect the soldering tool from the soldering station and connect the i-Set Tool.
- Turn the i-OP and select the following: Upload: The data of the station is written into the i-Set Tool. Download: The data of the i-Set Tool is written into the station. Then, push the i-OP.

A confirmation prompt is displayed:

- Select [Abort] to end the process or [>>>] to continue.
- Push the i-OP; the settings will be saved. Wait until the text [Parameter saved] is displayed. Then, remove the i-Set Tool.



Display contrast, calibration and offset are not transferred. When transferring data to the soldering station, the parameters for all soldering tools will be overwritten. Take note of this when you operate different soldering tools at your soldering stations.

Even though the soldering station is equipped with a serial PC-interface (option), the device number of the station is not transmitted.

6.3.2 Set temperature

The set temperature is the desired soldering tip temperature.



In the work mode, the soldering tip temperature can be directly changed by turning the i-OP. Confirm this by pushing the i-OP.

```
Parameter
**  E N D  **
Temp Set  350 c
Calibrate +000 c
Tip-Offset 01
TEMPERATURE 150-450C / 300-842F
```

6.3.3 Calibration temperature

Use this function to calibrate the soldering tip temperature. It makes it possible to adjust the display value and actual tip temperature. The adjustable calibration range is -70...+50°C/-126...+90°F.

The exact calibration procedure is described in chapter 6.3.5. "i-CON 1 Calibration".



If you do not have a corresponding measuring unit for this measurement, please enter "0" into this parameter field.

```
Parameter
**  E N D  **
Temp Set  150 c
Calibrate +000 c
Tip-Offset 01
ADJUST TIP-TEMP -70/126...+50/90
```

6.3.4 Tip offset

(Function reserved)

```
Parameter
Temp Set      152 c
Calibrate     +000 c
Tip-Offset    01
Power Level   med.
01=NO OFFSET FOR THIS TOOL
```

6.3.5 Calibrating the i-CON 1

Use the calibration temperature (see 6.3.6 “Calibration” temperature) to exactly synchronize the actual tip temperature with the displayed temperature. The following procedure must be observed for the calibration:

- Input of desired set temperature (Chapter 6.3.2 “Set temperature”).
- Set the calibration temperature (Chapter 6.3.6 “Determination of calibration temperature”).

```
Parameter
**  E N D  **
Temp Set      150 c
Calibrate     +000 c
Tip-Offset    01
0DJUST TIP-TEMP -70/125...+50/90
```

6.3.6 Calibration temperature

```

Parameter
**  E N D  **
Temp Set   150 °C
Calibrate  +000 °C
Tip-Offset  01
DJUST TIP-TEMP  -70/125...+50/90
    
```

- Determine the soldering tip temperature with a calibrated measuring device (e.g. ERSA DTM 100).
- Compare the two displayed values of i-CON 1 and the measuring device.
- Calculate the temperature difference: $\Delta T = T_{i-CON 1} - T_{measuring\ device}$
- Set the calculated temperature difference ΔT (with algebraic sign via the rotary motion at the i-OP) in the menu item [Calibrate].



Quiet air conditions are important for the prevention of measurement errors.

6.3.7 Power Level

```

Parameter
Calibrate  +000 °C
Tip-Offset  01
Power Level med.
Standby-Time 02min
MEDIUM TEMPERATURE OVERSHOOT
    
```

This function enables the user to influence the regulating behaviour of the station, whereby the heating and after heating behaviour of the station can be matched to the actual application. Three settings are possible: [high], [med.] and [low].

- [Low]: Minimum post-heating characteristics. For soldering works with low heat demand.
- [Med.]: Increased post-heating characteristics. For soldering works with increased heat demand.
- [High]: Maximum post-heating characteristics. For soldering works with very high heat demand.

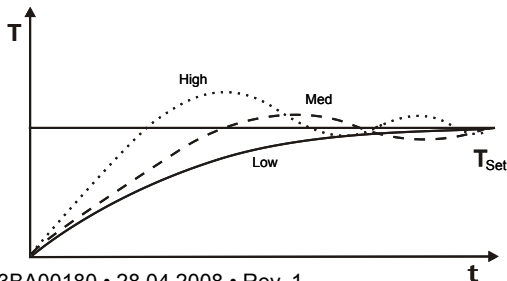

6.3.8 Standby-Time



The standby period is the time from the last work with the soldering tool to the point when the standby temperature is activated. The setting range is between 20 seconds and 60 minutes. The input [0] deactivates the standby function.



For small soldering points or soldering works which are performed with very little motion, a sufficiently high standby-time should be selected. Otherwise the standby-function may lower the temperature already during the soldering process!

As a measure to save energy and to prolong the lifetime of soldering tip and heater you can automatically trigger an idle state for the soldering tool. Please read section 6.4.6.

6.3.9 Standby-Temperature



This is the soldering tip temperature during work breaks. It is automatically activated when the standby-time has elapsed. When the temperature is decreased, power is saved and the service life of tip and heating element is increased.



Reheating to standby temperature is accomplished either by moving the i-Tool or by pressing / turning on the i-OP.

6.4 Configuration mode



In the configuration mode, the following settings are possible:

- Temperature window (monitoring)
- Device number
- process alarm (acoustic temp. monitoring)
- Idle state
- password
- temperature unit
- language selection of the station

To reach the configuration mode, keep the i-OP pushed for 5 seconds when you switch on the i-CON 1.

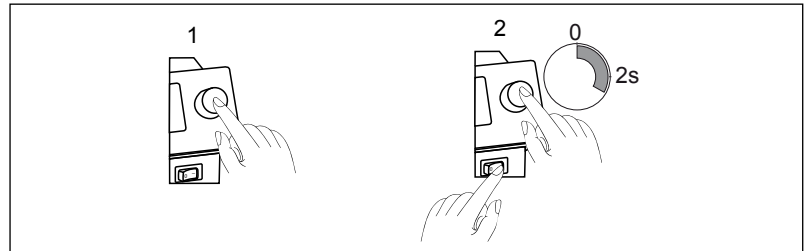



- turn the i-OP to select the menu option, then press:
 - [CHANGE] opens the menu [Configuration]
 - [ABORT] aborts the process
 - [DEFAULT] restores the factory settings.



If the password lock is active, the soldering station cannot be reset to its delivery status (default) without the password.

6.4.1 Temperature window

For the connected soldering tool a temperature window with an upper and lower range can be defined.

If the actual temperature is within this window, the work dialog displays an "OK".

Factory setting: $\pm 20^{\circ}\text{C}$ (68°F).



6.4.2 Process alarm

If the actual temperature leaves the temperature window, a single acoustic signal is generated. If the actual temperature returns to the temperature window, a double acoustic signal is generated. Factory setting: [off]

(Function reserved).

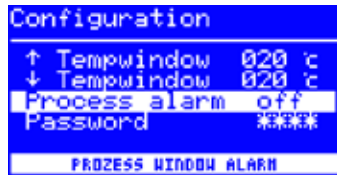

6.4.3 Password lock

The data of the station can be protected by a 4-digit (0001-9999) password. This way, settings/changes can be prevented. The station does not come with activated password lock; this is indicated by "0000" in the password input field.

The symbol ⓘ signals that the station is protected. Factory setting: [0000] = unlocked.



Please memorize your selected password thoroughly or note it down at a safe spot. Only ERSA can deactivate a forgotten password. If you have an i-Set Tool with the saved factory settings, you can also unlock the station on your own.



6.4.3.1 Setting the password

Proceed as follows in order to activate the [password] function:

- Open the configuration mode, select the [change] item.
- Activate the [Password] function via turning the i-OP.
- Press the i-OP to activate the cursor, pressing the i-OP subsequently de-activates the cursor.



If the cursor is activated, the value of the parameter is changed accordingly when the i-OP is turned.

- Enter the desired password (number between "0001" and "9999") by turning the i-OP: Clockwise up, counter-clockwise down.

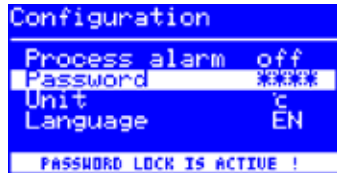

```

Password activation!
-----
A NEW PASSWORD IS ACTIVATED !!!
CHANGES CAN TAKE PLACE ONLY
WITH THIS NEW PASSWORD !!!
NOTE & KEEP THIS PASSWORDCODE !

[PASOR] >>>
    
```

```

Password activation!
-----
** PASSWORD - CONFIRMATION **
REPEAT NEW PASSWORD [0000]
    
```

```

Configuration
-----
Process alarm off
Password *****
Unit c
Language EN

PASSWORD LOCK IS ACTIVE !
    
```

- Confirm your input by pushing the i-OP. The first [Password activation] image is displayed:

Either

- Select the [ABORT] item to quit the process. The password lock will not be activated in this case.

Or

- Note down the adjusted password, select the [>>>] item (continue), confirm by pushing the i-OP.

The second [Password activation] image is displayed:

- Enter your password again and Confirm your input by pushing the i-OP.



The [Configuration] image with the message [PASSWORD LOCK IS ACTIVE!] is displayed. The station is now protected.

6.4.3.2 Changing the password



The password is set in the configuration mode. If a password has already been set, the code is displayed as asterisks.

If the user wants to change a password, the active password lock must first be revoked by entering the current password.

After the correct input, the new password can be set. If the numerical entry has been completed with the PUSH-function, a note is displayed indicating that the password lock is activated. The purpose of this note is to once more indicate the significance of this function to the operator. If the function is canceled, the previous state is maintained.

If the operator continues the dialog [>>>], the password must be repeated for activation.

If the password has been repeated correctly, the station is protected by the code. If the code has been entered incorrectly, a note is displayed and the previous state is maintained.

The symbol ① signals that the station is protected.

6.4.3.3 Input of values without deactivating the password

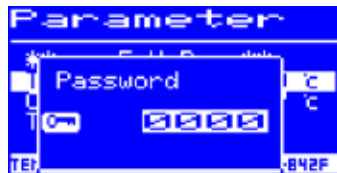

If values are to be changed, e.g. set value, without a deactivation of the password, a request to enter the password is issued when the value is tried to be changed. If the correct password is entered, the operator has approx. 30 sec. of time to perform his changes. If he performs settings during this time limit, the time limit will be extended by another 30 sec. each time. This way, further settings can be performed. If no input is carried out for 30 sec., the password lock will be re-activated.

6.4.3.4 Forgotten password

If you have forgotten your password, it can only be de-activated by ERSA Service. In such a case, please refer to the company ERSA, indicating your address, name, invoice and serial number of the soldering station (see type plate). The password lock may also be de-activated with the i-Set Tool. Please observe the corresponding hint at section 6.4.3 to this purpose!

6.4.4 Temperature unit

Here, the desired temperature unit, degree Celsius (°C) or Fahrenheit (°F), can be selected. Factory setting: "°C"



Caution! When the temperature unit is changed, a setup mode is carried out. During this time (approx. 5 sec.), the station must not be switched off.

6.4.5 Language selection

Here, the desired language for the menu navigation of the i-CON 1 can be selected. Factory setting: "English".



6.4.6 Adjustable shut-down function (idle state)



The adjustable shut-down function (idle state) serves the purpose of energy saving and prolonging the lifetime of soldering tip and heater. In idle state the tools cool down to room temperature. The bottom line in the display then shows the text [Shut Down]. You can end the idle state at any time by actuating the i-OP.

Please proceed as follows to activate the function [Shut Down]:

- Open the configuration mode and choose the option [Shut Down].
- Activate the menu [Shut Down] by turning the i-OP.
- Press the i-OP to activate the cursor, press the i-OP again de-activates the cursor
- Enter the desired time from [010] to [240] minutes by turning the i-OP accordingly. The input [000] deactivates the function [Shut Down].



If the cursor is activated, turning the i-OP changes the value of the parameter accordingly. The set time starts to run, only after the tool is in [Standby]. If the tool is still not used during this time, idle state is activated after this time has expired.

The standby condition is automatically terminated when the soldering tool is taken out of the storage stand or when the i-OP is operated.

6.4.7 Device number

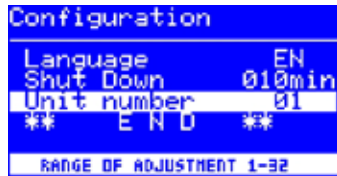

This function is only required, if the i-CON 1 is equipped with a serial PC-interface (Option). An unambiguous device number must be assigned for identification, to enable the PC to correctly allocate the connected station.

Please proceed as follows to set the [Unit number]:

- Open the configuration mode and choose the option [Unit number].
- Activate the menu [Unit number] by turning the i-OP.
- Press the i-OP to activate the cursor, press the i-OP again de-activates the cursor.
- Enter the desired number from [01] to [32] by turning the i-OP accordingly.



If the cursor is activated, turning the i-OP changes the value of the parameter accordingly. Details for correct assignment of device numbers can be found in the documentation for the serial PC-interface. Each station must have its own number. A double assignment of a number is not unambiguous and can lead to malfunction.

6.5 Factory settings (“default”)

The following lists shows the settings with which the station was programmed in our works. These settings can be restored via the “default function” in the “Configuration” mode. The only exception is the setting of the password which is not deleted via the default function.

Configuration mode	
Parameter	Settings
↑ Tempwindow	20 °C
↓ Tempwindow	20 °C
Shut down	000
Unit number	01
Process alarm	Off
Password	0000 (is not deleted via the default function)
Unit	°C
Language	EN

Parameter mode	
Parameter	Settings
Tempset (°C)	360
Calibrate (°C)	0
Tip-Offset	1
Power level	Medium
Standby-Time (min)	5
Standby-Temp (°C/°F)	250

6.6 Contrast



Follow these steps to adjust the contrast of the display to the respective work environment:

- Switch on the station and rotate the i-OP immediately. This activates the [Contrast] mode.

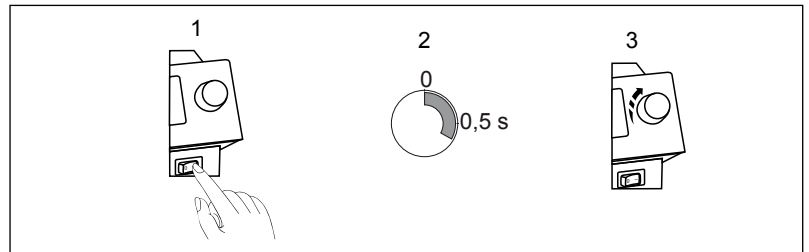

- Adjust the desired contrast by turning the i-OP.
- Confirm your input by pushing the i-OP.

6.7 Replacing the soldering tip

Replace the soldering or desoldering tip when they are worn. Before replacing the soldering tip:

- Switch off the station and let the soldering tip cool off.



Attention! Only replace the tips when they are cold - burn hazard!

When the tip has cooled off, proceed as follows:

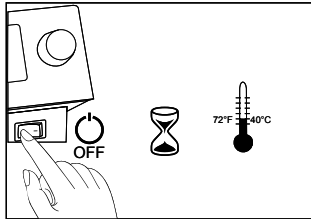

6.7.1 i-Tool

- Loosen the soldering tip by turning the knurled nut counter-clockwise.

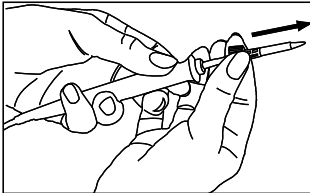
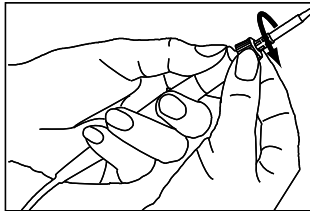

- Pull the tip and the retainer off of the heating element.



- Carefully push the soldering tip out of the collar. Do not bend!



Attention! Do not press on top of the tip! Risk of injury!

- Carefully pull the new soldering tip into the retainer, until it engages. Do not bend!

- Slide the new soldering tip and the collar onto the heating element.

- Screw the tip tightly onto the soldering iron by turning the knurled screw clockwise.



Caution! Do not operate soldering tools without soldering tip! By this means the heating element may be damaged!

6.8 Changing the Heating Element

Before changing a heating element:

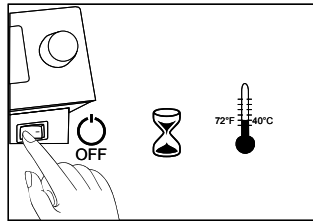

- Switch off the station and let the soldering tip cool off. Subsequently remove the soldering tip as described above.



Attention! Only replace the heating elements when they are cold - burn hazard!

6.8.1 i-Tool

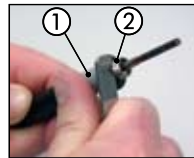

- Position the tweezers tool between handle ① and thread ②



- Loosen the heating element by levering it slightly



- Pull out the loosened heating element

Operating instructions

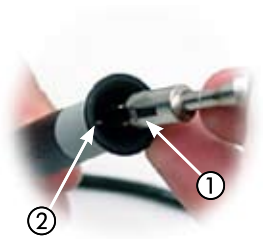

- Slide the new heating element into the handle
- Pay attention that the slot ① in the heating element matches the pin ② in the handle.
- Firmly push the heating element into the handle.

6.9 Sensitive components

Many components may be damaged by electrostatic discharge (please observe the warnings on the packaging or ask the manufacturer or supplier). These components can be protected by an ESD-secure workplace (ESD = electrostatic discharge). The soldering station can be easily integrated into such an environment. The soldering tip can be connected at high resistance (220k Ω) to the conductive workbase via the potential equalization jack (1).

The soldering station has complete antistatic protection and also meets the requirements of the American military standard.

The soldering tips are default hard grounded.

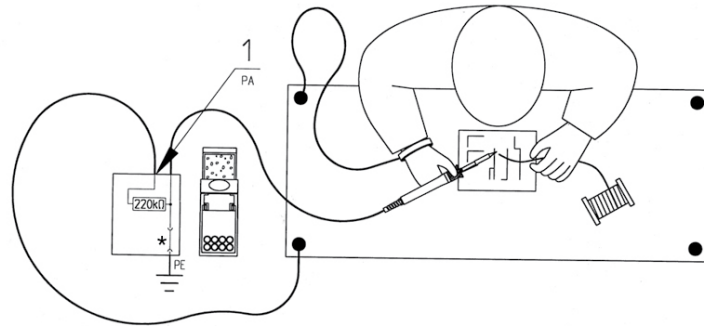

*Hard grounded in accordance with military and ESA standard.

7. Error diagnosis and remedy

7.1 General Errors

If the soldering station does not operate as expected, check the following items:

- Is main voltage present? Correctly connect the mains lead to the device and socket.
- Is the fuse defect? The fuse can be found at the rear side of the device in the mains connecting socket.
- Note that a defective fuse may also indicate a deeper cause of error. Simply changing the fuse therefore generally does not suffice.
- Is the soldering tool correctly connected to the supply unit?

7.2 Other Errors

Other errors may also occur, indicating possible defects in the soldering tool. These errors are:

- The station permanently only displays the room temperature. This indicates a fault on the heater or in the supply line.



If the station is in idle state, the room temperature will also be displayed after a few minutes!

- The display is switched off and no longer displays anything, but the mains switch continues to be illuminated. In this case, the soldering station is overloaded. Once the soldering station has cooled down sufficiently (approx. 30 minutes), work can be continued.



7.3 Continuity check for i-Tool

If the soldering tip is not heated up after the previously mentioned points have been checked, you can check the heater resistor and the temperature sensor with an ohmmeter for conductance.

7.3.1 Heating element

The continuity resistance between measuring points ① and ② should be approx. 3,5 - 4,5 Ohm (at cool soldering iron). In the event of interruption, the heating element is to be replaced (⑦ = potential equalization).

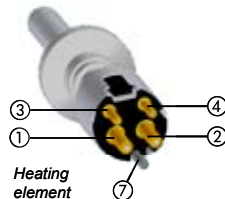

7.3.2 Thermocouple

There should be approx. 2 - 3 Ohm continuity resistance between measuring points ③ and ④. If the continuity resistance is higher, the tool has to be repaired.

With a measuring at the plug (heating element must be mounted in the soldering iron) there should be approx. 3,8..5 Ohm between measuring points ⑤ and ⑥.

7.4 Parameter changes not possible

If the station is protected by a password, the parameters only can be changed by entering the correct password. (see chapter 6.4.3 "Password lock").

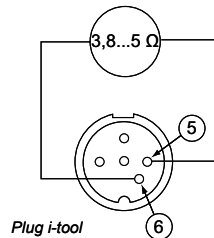

7.5 Error Messages

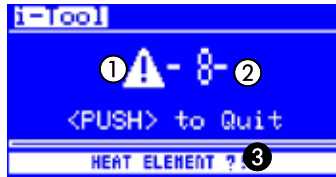

The i-CON 1 carries out an automatic error diagnosis. The result of a diagnosis is displayed as an error code: The triangular pictograph ① appears in the display of the soldering station. The error code ② is displayed as a number between 2 and 99. Additionally, an information text ③ is displayed in the bottom line. The error codes are listed in the following table. Error messages have to be confirmed with the i-OP. After the error has been eliminated and the error message has been confirmed, the connected soldering tool will be heated again.

Code	Test in display	Cause	Remedy
2	[CALIBRATION FATAL ERROR !]	Station no longer calibrated	Have factory calibration carried out
4	[RT-compensation]	Measurement reading of KTY not ok	Have soldering tool and soldering station checked
7	[HE MISSING ? SENSOR ?]	Heating element is not installed correctly Thermocouple error	Install heating element correctly Have soldering tool checked
8	[HEAT ELEMENT?]	Heater defect	Check heating element / Check soldering station
9	[DATA LOST!]	Parameter/Configuration data destroyed	Reset soldering station to factory setting in the configuration mode
71	[ITool AND HE DEFECTIVE/ EXCHANGE]	Both the electronics and the heating element of the i-Tool are defective.	Replace the i-Tool
98	[MAINS FREQUENCY ERROR]	Mains frequency outside of frequency range ($\pm 10\%$)	-
99	[iCON OVERLOAD PROTECTION]	Soldering station overloaded	Allow the soldering station to cool down

8. Maintenance

8.1 Important care jobs

To ensure a long service life of your station, a few points must be observed.

- Make sure that the soldering and desoldering tip is always tinned. A soldering tip which is always clean will become passive within a short time. If you always leave a small amount of solder at the soldering tip when you stop soldering, the service life increases substantially.
- If necessary wipe the soldering tip only just before the start of the soldering process.
- To obtain good electrical and thermal conductivity, occasionally remove the soldering tip and clean the heating element shaft with a brass brush.
- Make sure that the effectiveness of the ventilation holes is not impaired by a build-up of dust.



Only use genuine ERSA consumables and spare parts to ensure reliable functionality and warranty!



Warning! There are no parts to be maintained within the device!





8.2 Cleaning

Occasionally clean the device with a moistened soft cloth. Steam cleaners, pressure washers, scrubbing sponges, abrasives, solvents like alcohol or benzine must not be used!

9. Replacement parts

Replacement parts		
	Description	Order-no.
Soldering stations		
	i-CON 1 electronic station, 80 W, antistatic, compl. with 1 i-Tool soldering iron and holder	01C 1100A
Single parts		
	i-CON 1 electronic station, 230/24 V, 80 W, antistatic	01C 113 A
	i-tool soldering iron, 24 V, 150 W antistatic with tip 0102CDLF16	0100 CDJ
	Holder for i-Tool	0A50
	Heating element and tip change tweezers for i-Tool, i-Tips	3N 544
	i-Set Tool	0103IST

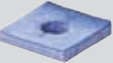
Operating instructions

Replacement parts		
	Description	Order-no.
	Knurled nut for i-Tips	3N 497
	Collar for i-Tips	3N 539
	Knurled nut with jointing sleeve for i-Tips	3IT1040-00
	Heating element for i-Tool	010102J
	Viscose sponge for holder	0003B
	Brass brush	3ZT00051
	Drying sponge	0008M

9.1 ERSADUR Long-Life Soldering tips (i-Tips)

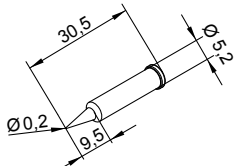
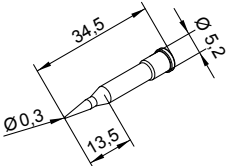
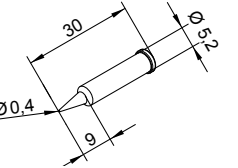
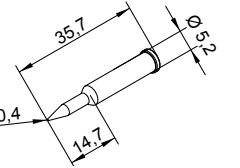
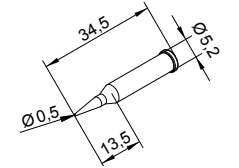
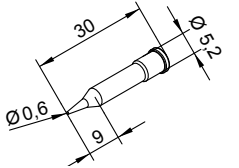
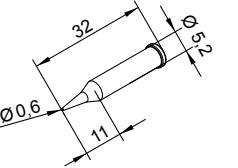
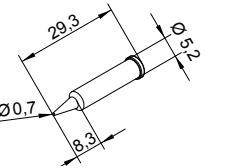
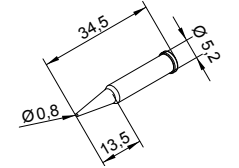
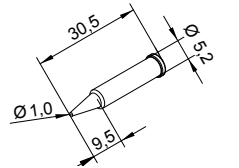
i-Tips [P]			
 <p>0102PDLF02</p>	 <p>0102PDLF03L</p>	 <p>0102PDLF04</p>	 <p>0102PDLF04L</p>
 <p>0102PDLF05L</p>	 <p>0102PDLF06</p>	 <p>0102PDLF06L</p>	 <p>0102PDLF07</p>
 <p>0102PDLF08L</p>	 <p>0102PDLF10</p>		

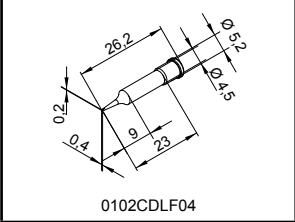
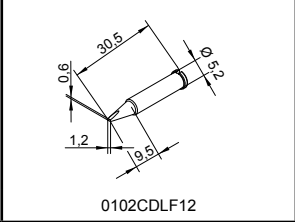
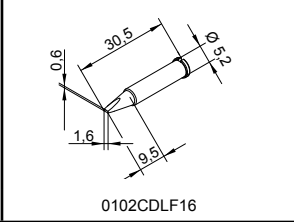
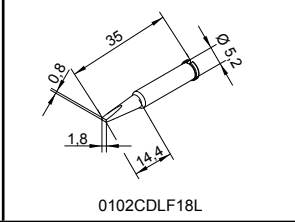
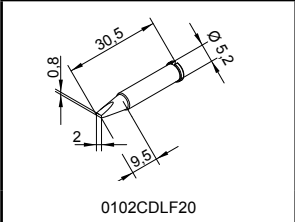
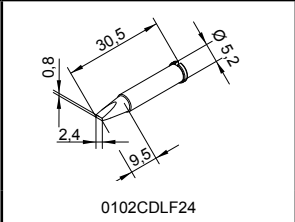
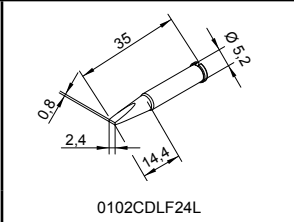
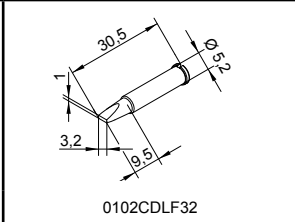
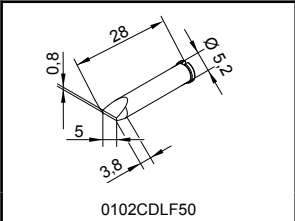
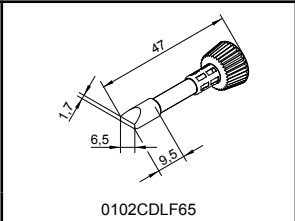
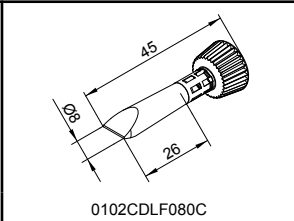
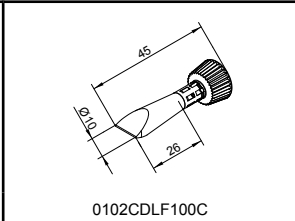
i-Tips [C]			
 <p>0102CDLF04</p>	 <p>0102CDLF12</p>	 <p>0102CDLF16</p>	 <p>0102CDLF18L</p>
 <p>0102CDLF20</p>	 <p>0102CDLF24</p>	 <p>0102CDLF24L</p>	 <p>0102CDLF32</p>
 <p>0102CDLF50</p>	 <p>0102CDLF65</p>	 <p>0102CDLF080C</p>	 <p>0102CDLF100C</p>

Operating instructions

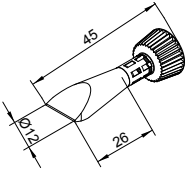
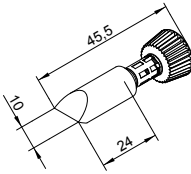
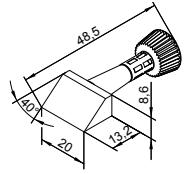
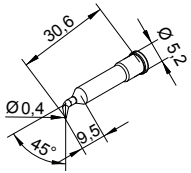
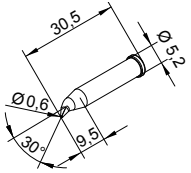
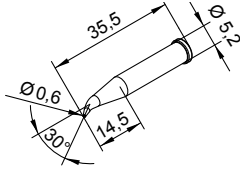
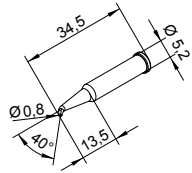
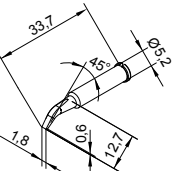
i-Tips [C]			
 <p>0102CDLF120C</p>	 <p>0102CDLF100</p>	 <p>0102CDLF200</p>	
i-Tips [S]			
 <p>0102SDLF04</p>	 <p>0102SDLF06</p>	 <p>0102SDLF06L</p>	 <p>0102SDLF08L</p>
 <p>0102SDLF18</p>			

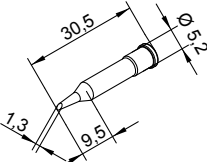
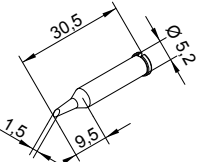
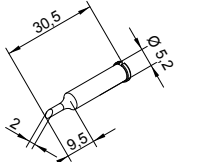
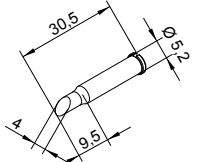
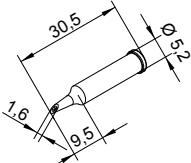
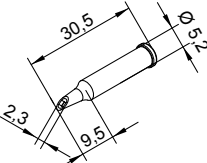
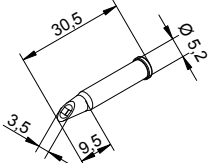
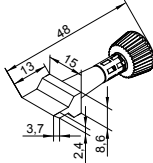
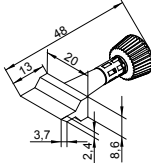
i-Tips [A]			
 <p>0102ADLF13</p>	 <p>0102ADLF15</p>	 <p>0102ADLF20</p>	 <p>0102ADLF40</p>
i-Tips [W]			
 <p>0102WDLF16</p>	 <p>0102WDLF23</p>	 <p>0102WDLF35</p>	
i-Tips [Z]			
 <p>0102ZDLF150</p>	 <p>0102ZDLF200</p>		

Operating instructions

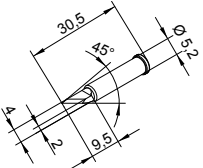
i-Tips [B]		
 <p>0102BDLF20</p>		
<p>Consideration! Before you start to solder please remove the possibly existing hose protection nozzle.</p>		

10. Warranty

© 05/2008, ERSA GmbH • 3BA00180 Rev. 1

Heating elements and soldering or desoldering tips are treated as wearing parts, and are therefore not subject to the warranty. Any return of goods must be accompanied by a written description of the material or construction fault that has occurred as well as a confirmed purchase invoice.

ERSA created these operating instructions with careful attention to detail. However, no warranty can be given covering content, completeness and quality of specifications in this manual. The content is continuously maintained and modified to the current conditions.

All data published in this manual, including specifications concerning products and procedures, was determined by us to the best of our knowledge and ability, and using the most modern technical aids. These specifications are non-binding and for information only; they do not relieve the user from the responsibility of carrying out his own check before operation of the device. We are not liable for violations of patent rights of third parties for usage and procedures without previous express and written confirmation.

We reserve the right for technical modifications with the intention of improving the product. In the context of the legal possibilities, liability for any damage, including direct and indirect damage, which results from the acquisition of this product, is ruled out.

All rights are reserved. This manual, or any parts thereof, may not be transferred, reproduced, or translated into another language without the written permission of ERSA GmbH.