

Contact insert - VC-AMS 2 - 1853528

Please be informed that the data shown in this PDF Document is generated from our Online Catalog. Please find the complete data in the user's documentation. Our General Terms of Use for Downloads are valid (<http://download.phoenixcontact.com>)



Contact insert module, for panel mounting frames, with screw connection, 2-pos., 400 V / 20 A

Product Features

- Compact design
- Proven COMBICON technology
- Universal connection
- Can be keyed to prevent incorrect connection

Key commercial data

package_quantity	50
GTIN	4017918127060

Technical data

General

Note	Connectors may only be connected/disconnected when under no load.
Connection method	Screw connection
Connection method	Screw connection
Tightening torque	0.5 Nm ... 0.6 Nm
Pollution degree	3
Surge voltage category	III
Number of positions	2
Insertion/withdrawal cycles	≥ 100
Conductor cross section AWG/kcmil min.	24
Conductor cross section AWG/kcmil max	12
2 conductors with same cross section, solid min.	0.2 mm ²
2 conductors with same cross section, solid max.	2.5 mm ²
2 conductors with same cross section, stranded min.	0.2 mm ²
2 conductors with same cross section, stranded max.	1.5 mm ²
2 conductors with same cross section, stranded, ferrules without plastic sleeve, min.	0.25 mm ²
2 conductors with same cross section, stranded, ferrules without plastic sleeve, max.	1.5 mm ²
2 conductors with same cross section, stranded, TWIN ferrules with plastic sleeve, min.	0.5 mm ²

Contact insert - VC-AMS 2 - 1853528

Technical data

General

2 conductors with same cross section, stranded, TWIN ferrules with plastic sleeve, max.	2.5 mm ²
Conductor cross section	0.2 mm ² ... 4 mm ²
Connection cross section AWG	24 ... 12
Stripping length of the individual wire	10 mm

Ambient conditions

Ambient temperature (operation)	-40 °C ... 100 °C
----------------------------------------	-------------------

Material data

Inflammability class according to UL 94	V0
Contact material	CuZn
Contact surface material	Tin-plated
Contact carrier material	PA

Electrical characteristics

Rated voltage (III/3)	400 V
Rated surge voltage	6 kV
Rated surge voltage	6 kV
Rated current	20 A

classifications

eCl@ss

eCl@ss 4.0	27140816
eCl@ss 4.1	27140816
eCl@ss 5.0	27143424
eCl@ss 5.1	27143424
eCl@ss 6.0	27143424
eCl@ss 7.0	27440209
eCl@ss 8.0	27440209

ETIM

ETIM 2.0	EC000438
ETIM 3.0	EC000438
ETIM 4.0	EC000438
ETIM 5.0	EC000438

UNSPSC

UNSPSC 6.01	30211923
UNSPSC 7.0901	39121522
UNSPSC 11	39121522
UNSPSC 12.01	39121522
UNSPSC 13.2	39121522

Contact insert - VC-AMS 2 - 1853528

approvals

UL Recognized / cUL Recognized / GOST / LR / GOST / cULus Recognized /

Approval details

UL Recognized	
Nominal voltage UN	600 V
Nominal current IN	20 A
mm ² /AWG/kcmil	30-10

cUL Recognized	
Nominal voltage UN	600 V
Nominal current IN	20 A
mm ² /AWG/kcmil	30-10

GOST

LR

--

cULus Recognized

accessories

Coding element

Contact insert - VC-AMS 2 - 1853528

accessories

CP-HCC 4 - 1600027



Drawings

Diagram

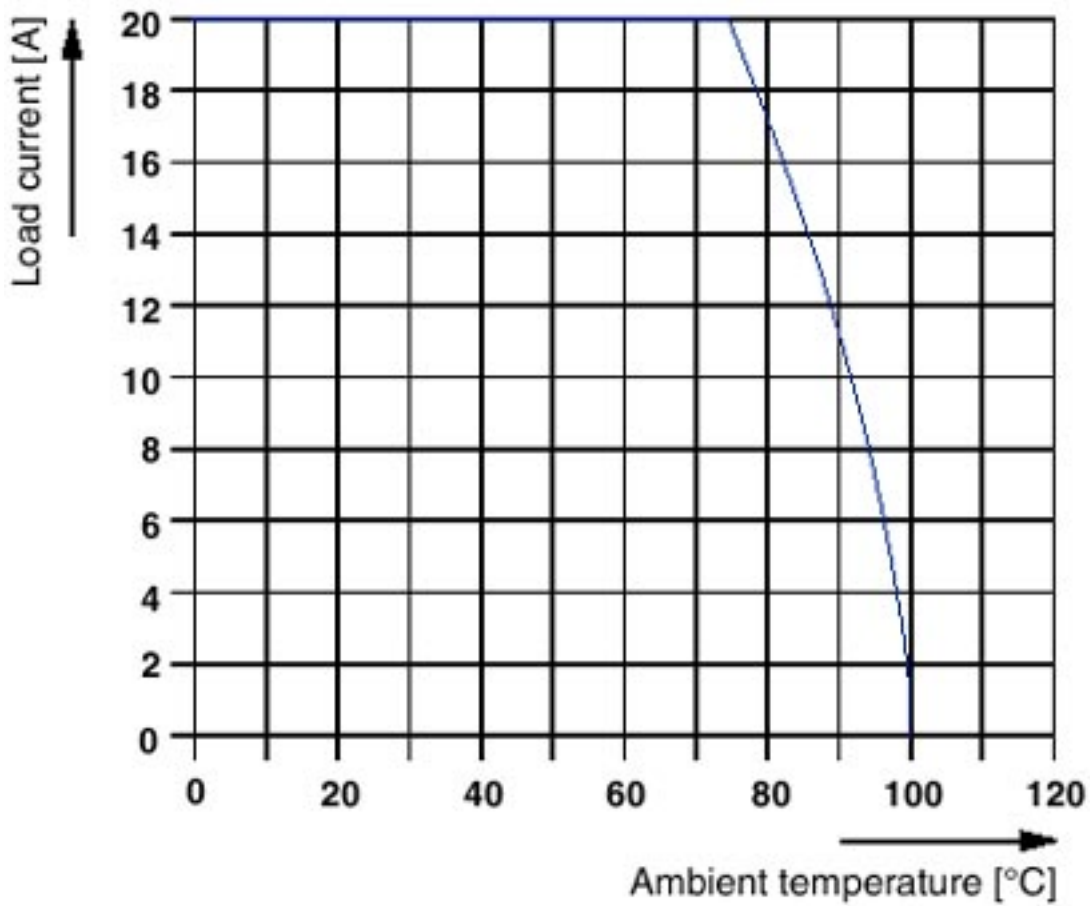

Contact insert - VC-AMS 2 - 1853528

Dimensioned drawing

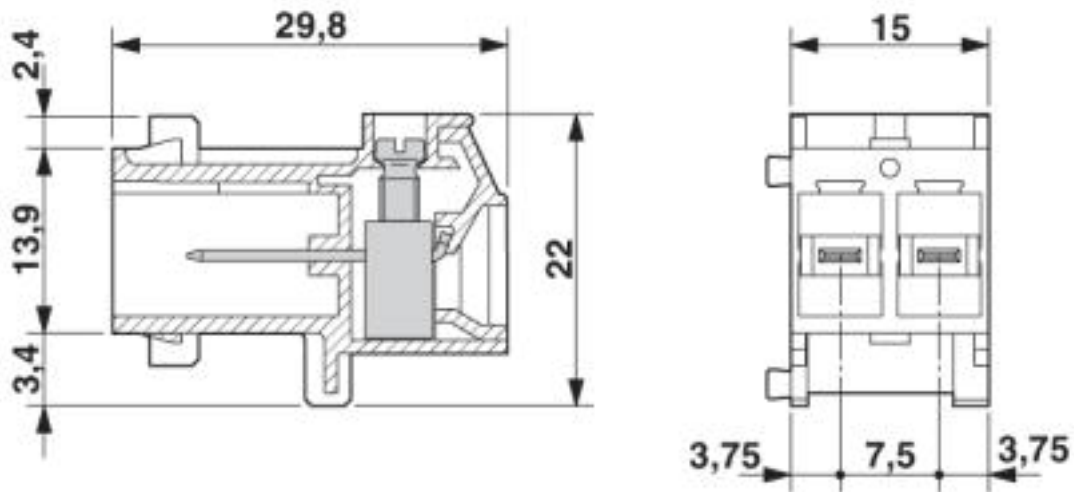

© Phoenix Contact 2013 - all rights reserved
<http://www.phoenixcontact.com>