

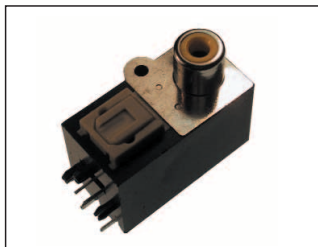

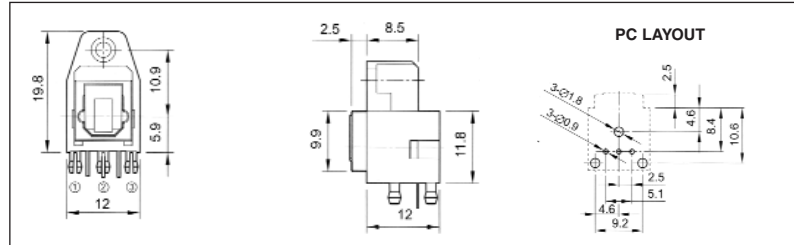

**OTJ-5/ORJ-5 Single Optical Transmitter and Receiver Jack. Right angle PCB mount with self tapping hole for panel mounting. Hinged shutter.**

**OTJ-5 (FC684205T)  
ORJ-5 (FC684205R)**



**OTJ-6/ORJ-6 Dual SPDIF RCA and Optical Transmitter and Receiver Jack. Right angle PCB mount with self tapping hole for panel mounting. Hinged shutter. Several different colored inserts available.**

**OTJ-6 (FC684206T)  
ORJ-6 (FC684206R)**

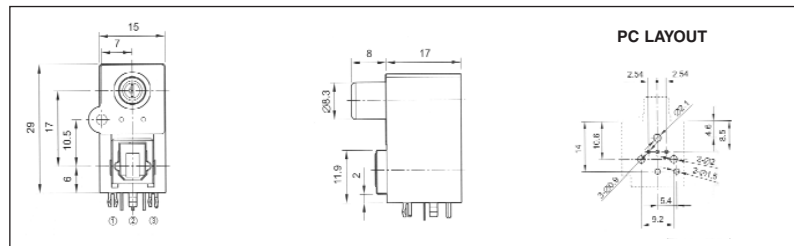

**OTJ-8/ORJ-8 Optical Transmitter and Receiver Jack. Right angle PCB mount. Hinged shutter.**

**OTJ-8 (FC684208T)  
ORJ-8 (FC684208R)**

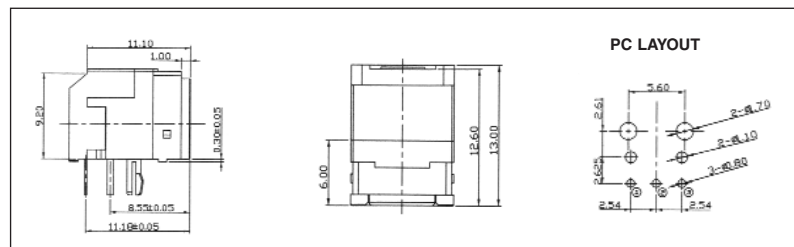

### Electrical Specifications:

**Supply Voltage:** -0.5 to 7.0V Maximum.

**Input Voltage:** -0.5 to +0.5V Maximum.

**Operating Temperature:** -20 deg. C to +70 deg. C Maximum.

**Storage Temperature:** -30 deg. C to +80 deg. C Maximum.

**Soldering Temperature:** 260 deg. C Maximum.

### Mechanical Specifications:

**Insertion Force:** 5.9N Minimum, 39.2N Maximum.

**Withdrawal Force:** 5.9N Minimum, 39.2N Maximum.

### Materials:

**Body:** PBT +30G, ABS 94-V-0 (depends on model)

**Shutter:** Nylon PA66

Please refer to the individual technical data sheets available for each model for the recommended operating conditions, characteristics, PC layouts and technical information. We also manufacture molded optical lead assemblies for use with our optical jacks. Please contact our sales office for more details.

D-045

基本尺寸及公差 JIS B0405				
插脚尺寸(mm)	公差等级 (mm)(%)			
	数量	公差	公差	公差
0.5-3	±0.05	±0.1	±0.2	-
3-6	±0.05	±0.1	±0.3	±0.5
6-30	±0.1	±0.2	±0.5	±1
30-120	±0.15	±0.3	±0.8	±1.5
120-400	±0.2	±0.5	±1.2	±2.5
使用基準	◎			

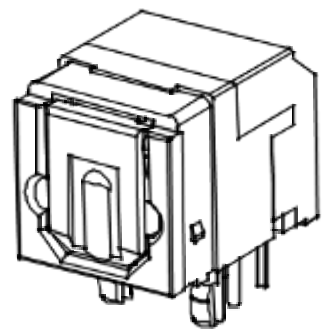
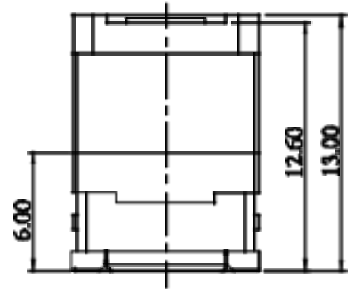
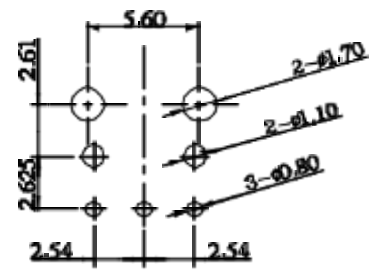

**BOTTOM VIEW**  
**P.C.B TOLERANCE ±0.05**  
**Recommended PCB thickness: 1.6 mm**

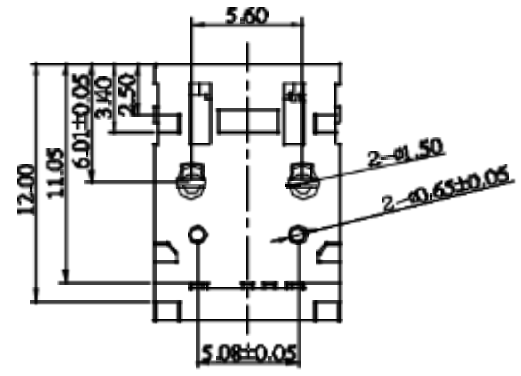
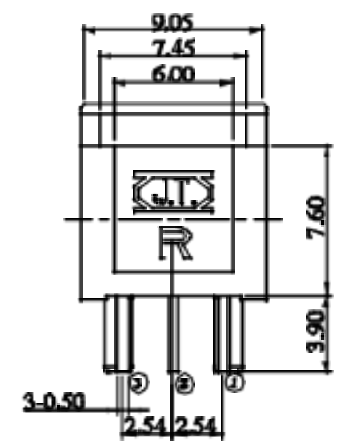
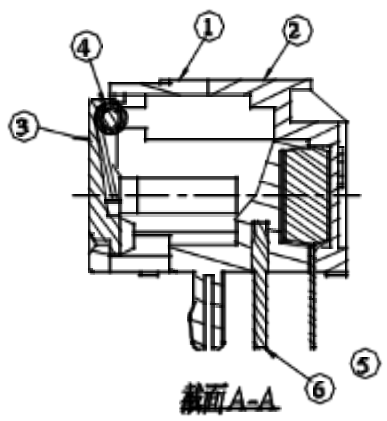
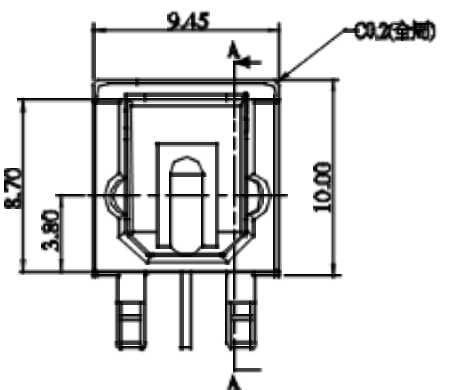
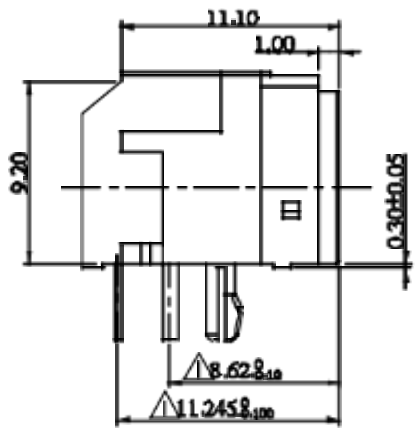

NO.	PARTNAME	PCS	MATERIAL	FINISH
6	NO.1 PIN	2	C1100W	
5	Receiver	1	SV(3mm)	
4	Coil Spring	1	SWPA	
3	Shutter	1	NYLON PA-66(黑)	BLACK
2	Case	1	NYLON PA-66(黑)	BLACK
1	Body	1	NYLON PA-66(黑)	BLACK

- Receive
- ① Vcc
  - ② GND
  - ③ Volt

PLAZICOLOR	AVAIL. QTY	ROLLS	△ X 2	D3.08.25	物料圖號: F04038020	圖號
TRUCKERS	24.8000	UNIT	RECY	DATE	REVISION	SENG
MATERIAL	AVAIL. 3rd	REORDER POINT	02.05.90	成日圖		
DESIGNED	TRUN	CHECKED	APPROVED	DATE	FRASE	REV: 1/1
捷泰精工工業股份有限公司						

# SPECIFICATION

CUSTOMER MODEL NO. / TITLE OPTICAL RECEIVING JACK (0802R, 0803R, 0807R, 0808R)	SPECIFICATION NO. FC684208R	PAGE : 1 OF 7 DATE : APR,29,2002
--	--------------------------------	-------------------------------------

Fiber optic receiving module for digital audio interface and navigation system.

Features:

- (1) Conform to EIAJ standard CP-1201 (for Digital Audio interfaces Including Fiber Optical inter-connectors).
- (2) A self-tapping hole for easy attachment to Audio Equipments panels.
- (3) High speed signal receiving  
(12.5Mbps NRZ signal)

## 1. Maximum Ratings (Ta=25°C)

Parameter	Symbol	Rating	Unit
Storage Temperature	T <sub>stg</sub>	-40 ~ 70	°C
Operating Temperature	T <sub>opr</sub>	-20 ~ 70	°C
Supply Voltage	V <sub>cc</sub>	-0.5 ~ 6	V
High Level Output Current	I <sub>OH</sub>	-1	mA
High Level Output Current	I <sub>OL</sub>	5	mA
Soldering Temperature	T <sub>sol</sub>	260 (1)	°C

Note (1): Soldering time ≤ 10 seconds (At a distance of 1mm from the package.)

## 2. Recommended Operating Conditions

Parameter	Symbol	MIN.	TYP.	MAX.	Unit
Supply Voltage	V <sub>cc</sub>	4.75	5.0	5.25	V

	A	C	C	W
	P	H	H	R
	V	K	K	T
REV. NAME DATE REMARK	D	D	D	N

Cliff Electronic Components Ltd.

# SPECIFICATION

CUSTOMER MODEL NO. / TITLE OPTICAL RECEIVING JACK	SPECIFICATION NO. FC684208R	PAGE : 2 OF 7 DATE : APR,29,2002
--	--------------------------------	-------------------------------------

### 3. Optical-electro Characteristics (Ta = 25°C, Vcc = 5V)

Parameter	Symbol	Conditions	MIN.	TYP.	MAX.	Unit.
Data Rate		NRZ Code (2)	0.1	-	12.5	Mb/s
Transmission Distance		Using APF (3), Using OC0802T	0.2	-	5	M
Pulse Width Distortion (4)	$\Delta tw$	Pulse Width = 147ns Pulse Cycle = 294ns $C_L = 10pF$ Using OC0802T	-15	-	15	ns
Maximum Receivable Power	$P_{MAX}$	12.5Mb/s, Using APF	-	-	-14.5	dBm
Minimum Receivable Power	$P_{MIN}$	12.5Mb/s, Using APF	-24	-	-	dBm
Current Consumption	$I_{CC}$		-	15	40	mA
High Level Output Voltage	$V_{OH}$		2.4	4.8	$V_{CC}$	V
Low Level Output Voltage	$V_{OL}$		-	0.2	0.4	V
Rise time	$t_r$	Refer to "Test Circuit"	-	10	20	ns
Fall time	$t_f$	Refer to "Test Circuit"	-	10	20	ns
Low→High delay time	$t_{pLH}$	Refer to "Test Circuit"	-	100	180	ns
High→Low delay time	$t_{pHL}$	Refer to "Test Circuit"	-	100	180	ns

Note (2): When non-modulated signal (optical all high or all low level signal) is inputted, output signal is not stable.

When modulated optical high level signal is received, output signal is high.

When modulated optical low level signal is received, output signal is low.

The duty factor must be maintained between 25 to 75%.

Note (3): All Plastic Fiber (970 / 1000 $\mu$ m).

Note (4): Between input of transmitting module and output of OC0802T.

### 4. Mechanical Characteristics (Ta= 25°C)

Parameter	Condition	MIN.	TYP.	MAX.	Unit
Insertion Force.	Using CLIFF OC-0801P,	-	-	39.2	N
Withdrawal Force.	Initial value	5.9	-	39.2	N
Torque for Self-Tap	Using self-tapping Screw (TP3×8)	58.8	-	78.4	N. cm

A	C	C	W
P	H	H	R
V	K	K	T
REV.	NAME	DATE	REMARK
D	D	D	N

Cliff Electronic Components Ltd.

# SPECIFICATION

CUSTOMER MODEL NO. / TITLE OPTICAL RECEIVING JACK	SPECIFICATION NO. FC684208R	PAGE : 3 OF 7 DATE : DEC,17,2002
--	--------------------------------	-------------------------------------

## TEST CIRCUIT

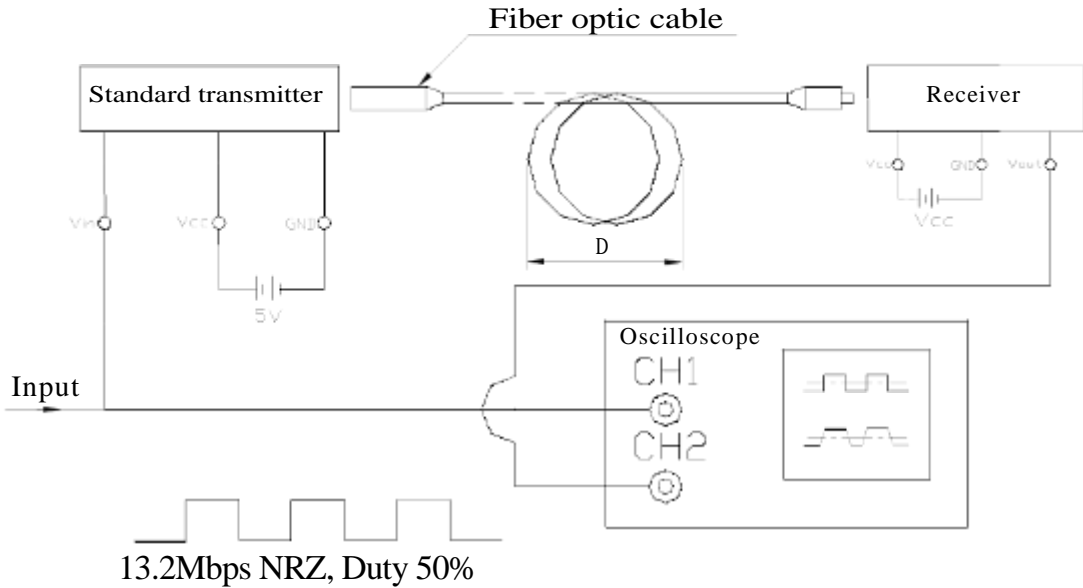

### Test item

Test item	Symbol	
Low → High pulse delay time	$t_{PLH}$	
High → Low pulse delay time	$t_{PHL}$	
Rise time	$t_r$	
Fall time	$t_f$	
Pulse width distortion	$\Delta tw = t_{PHL} - t_{PLH}$	$\Delta tw$
High level output voltage	$V_{OH}$	
Low level output voltage	$V_{OL}$	

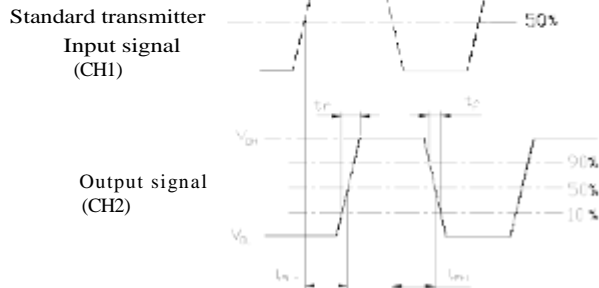

### Notes:

- 1) Vcc: 5V (State of operation)
- 2) To bundle up the standard fiber optic cable. Mark it into a loop with the diameter D=10cm.

	A	C	CW	
	P	H	H	R
	V	K	K	T
REV. NAME DATE REMARK	D	D	D	N

Cliff Electronic Components Ltd.

# SPECIFICATION

CUSTOMER MODEL NO. / TITLE OPTICAL RECEIVING JACK	SPECIFICATION NO. FC684208R	PAGE : 4 OF 7 DATE : APR,29,2002
--	--------------------------------	-------------------------------------

## 5. Application Circuit

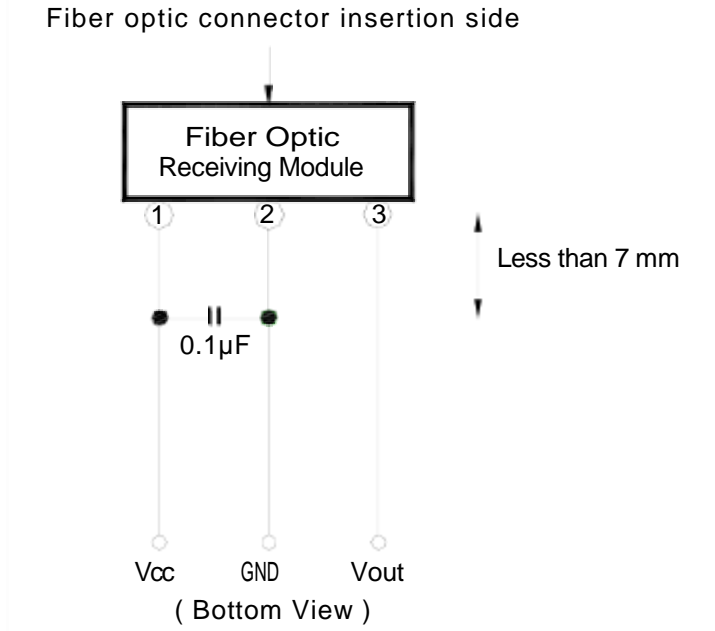

## 6. Required Optical Fiber with Fiber Optic Connectors

OC-0801P

	A	C	C	W
	P	H	H	R
	V	K	K	T
REV. NAME DATE REMARK	D	D	D	N

Cliff Electronic Components Ltd.

# SPECIFICATION

CUSTOMER MODEL NO. / TITLE	SPECIFICATION NO. FC684208R	PAGE : 5 OF 7 DATE : APR,29,2002
----------------------------	--------------------------------	-------------------------------------

## OPTICAL RECEIVING JACK

### 7. Precautions on Use

#### (1) Maximum rating

The maximum ratings are the limit values which must not be exceeded during operation of device.

None of these rating value must not be exceeded. If the maximum rating value is exceeded, the characteristics of devices may never be restored properly. In extreme cases, the device may be permanently damaged.

#### (2) Soldering

Optical modules are comprised of internal semiconductor devices. However, in principle, optical modules are optical components. During soldering, ensure that flux does not contact with the emitting surface or the detecting surface. Also ensure that proper flux removal is conducted after soldering.

Some optical modules come with a protective cap. The protective cap is used to avoid malfunction when the optical module is not in use. Note that it is not dust or waterproof.

As mentioned before, optical modules are optical components. Thus, in principle, soldering where there may be flux residue and flux removal after soldering is not recommended. Cliff recommend that soldering be performed without the optical module mounted on the board.

Then, after the board has been cleaned, the optical module should be soldered on to the board manually.

If the optical module cannot be soldered manually, use non-halogen (chlorine-free) flux and make sure, without cleaning, there is no residue such as chlorine. This is one of the ways to eliminate the effects of flux. In such a cases, be sure to check the devices' reliability.

#### (3) Noise resistance

It is believed that the use of optical transfer devices improve noise resistance. In theory, optical fiber is not affected by noise at all. However, receiving modules which handle signals whose level is extremely small, are susceptible to noise.

The optical module is to be used in an area which is susceptible to radiated noise, increase the shielding by covering the optical module and the power line filter with a metallic cover.

	A	C	C	W
DATE REMARK	P	H	H	R
	V	K	K	T
REV. NAME	D	D	D	N



# SPECIFICATION

CUSTOMER MODEL NO. / TITLE OPTICAL RECEIVING JACK	SPECIFICATION NO. FC684208R	PAGE : 6 OF 7 DATE : APR,29,2002
--	--------------------------------	-------------------------------------

(4) Vibration and shock

This module is plastic sealed and has its wire fixed by resin. This structure is relatively resistant to vibration and shock. In actual equipment, there are sometime cases in which vibration, shock, or stress is applied to soldered parts or connected parts, resulting in lines cut.

Care must be taken in the design of equipment which will be subject to high levels of vibration.

(5) Support pins

The OC0802R has support pins in order to fix itself to the PCB temporary. Please make the hole for these pins in the PCB under the condition described in board layout hole pattern.

(6) Panel attachment

OC0802R has hole for panel attachment. Please be sure to attach it to panel with self-tapping screw.

(7) Solvent

When using solvent for flux removal, do not use a high acid or high alkali solvent. Be careful not to pour solvent in to the optical connector ports. If solvent is inadvertently poured in to them, clean it off using cotton tips.

(8) Supply voltage

Use the supply voltage within the recommended operating condition ( $V_{cc} = 5 \pm 0.25V$ ). Make sure that supply voltage does not exceed the maximum rating value of 7V, even for an instant.

(9) Interface

The OC0802R has a TTL interface. It can be interfaced with any TTL-compatible C-MOS IC.

(10) Output

If the receiver output is at low and is connected to the power supply, or if the output is high and is connected to GND, the internal IC may be destroyed.

(11) Soldering condition

Solder at 260°C or less for no more than ten seconds.

	A	C	C	W
	P	H	H	R
	V	K	K	T
REV. NAME DATE REMARK	D	D	D	N

Cliff Electronic Components Ltd.

# SPECIFICATION

CUSTOMER MODEL NO. / TITLE OPTICAL RECEIVING JACK	SPECIFICATION NO. FC684208R	PAGE : 7 OF 7 DATE : APR,29,2002
--	--------------------------------	-------------------------------------

(12) Precautions when disposing of devices and packing materials.

When disposing devices and packing materials, follow the procedures stipulated by local regulations in order to protect the environment against contamination.

(13) Precautions during use

CLIFF is continually working to improve the quality and the reliability of their products. Nevertheless, semiconductor devices in general can malfunction or fail due to their inherent electrical sensitivity and their vulnerability to physical stress. It is the responsibility of the buyer, when utilizing CLIFF products, to observe standards of safety, and to avoid situations in which the malfunction or failure of a CLIFF product could cause loss of human life, bodily injury or damage to property.

Mating plug

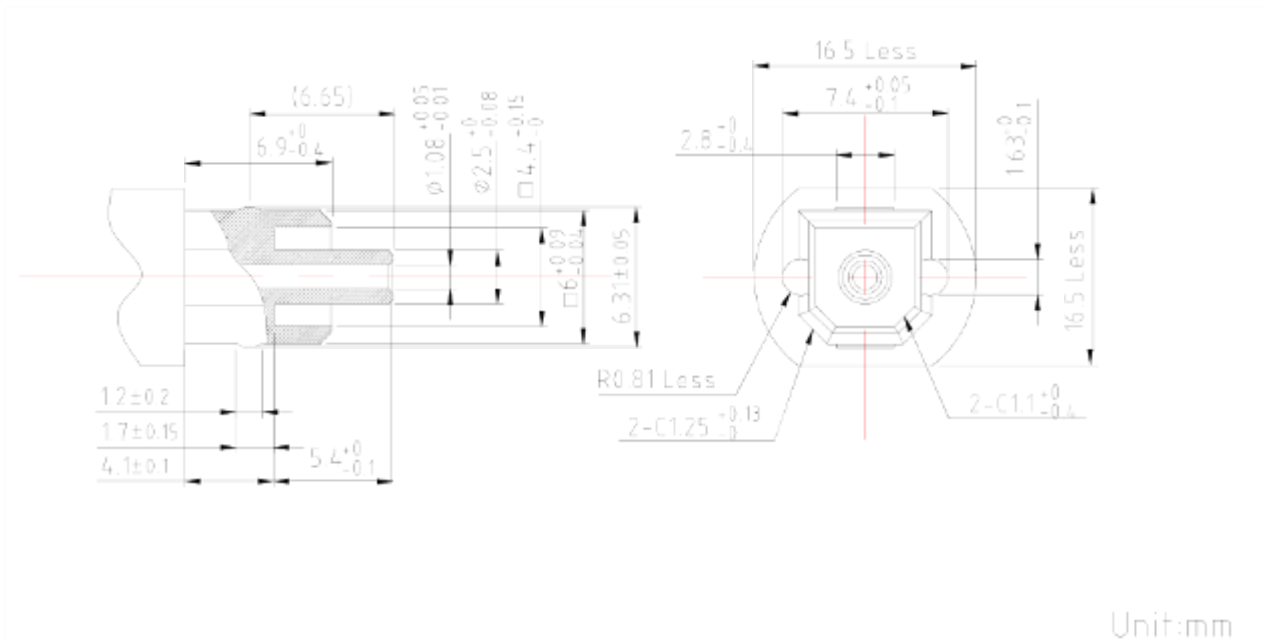

	A	C	C	W
	P	H	H	R
	V	K	K	T
REV. NAME DATE REMARK	D	D	D	N

Document No.	Document name	Rev.	DATE
01-E	Management standards for “Environment-related substances to be controlled”	1.6	OCT,26,2006

1. This part should not contain any substances which are specified in follow .(Except cadmium is less than 5ppm, Lead is under 90ppm)
2. In this case, pre-processing methods and measurement methods shall conform to ROHS.
3. List of “Environment-related Substances to be Controlled (“The Controlled Substances”)

Substances		Allowable concentration
Heavy metals	Cadmium and cadmium compounds	Less 5ppm
	Lead and lead compounds	Less 90ppm
	Lead in the plastic,rubber,paints,ink	Less 50ppm
	Mercury and mercury compounds	
	Hexavalent chromium compounds	
Chlorinated organic compounds	Polychlorinated biphenyls (PCB)	
	Polychlorinated naphthalenes (PCN)	
	Chlorinated paraffins (CP)	
	Mirex (Perchlordecone)	
	Other chlorinated organic compounds	
Brominated organic compounds	Polybrominated biphenyls (PBB)	
	Polybrominated diphenylethers (PBDE)	
	Tetrabromobisphenol-A-bis- (2, 3-dibromopropylether) (TBBP-A-bis)	
	Other brominated organic compounds	
Organic tin compounds (tributy tin compounds, Triphenyl tin compounds)		
Asbestos		
Azo compounds		
Formaldehyde		
Polyvinyl chloride (PVC) and PVC blends		

4. Allowable concentrations:

Less than 90ppm is determined as an allowable total-concentration of four heavy metals (mercury, cadmium, hexavalent chromium, and lead). Less than 5ppm is determined as an allowable cadmium-concentration in a plastic (including rubber) part.

A	C	C	W
P	H	H	R
V	K	K	T
D	D	D	N

REV. NAME DATE REMARK

Cliff Electronic Components Ltd.

**E I DUPONT DE NEMOURS & CO INC**

ENGINEERING POLYMERS CHESTNUT RUN PLAZA PO BOX 80713 WILMINGTON DE 19880

Material Designation: **70G33L(+)**

Product Description: Polyamide 66 (PA66), glass reinforced, designated "Zytel" furnished as pellets.

Color	Min. Thick. (mm)	Flame Class	HWI	HAI	RTI Elec	RTI Imp	RTI Str	IEC GWIT	IEC GWFI
ALL	0.71	HB	4	0	130	120	130	-	-
	1.5	HB	4	0	130	120	130	-	-
	3.0	HB	4	0	130	120	130	-	-
<b>CTI: 0</b>			<b>HVTR: 1</b>		<b>D495: 5</b>		<b>IEC BP: -</b>		

(+) Virgin and Regrind up to 50% by weight inclusive, have the same basic material characteristics.

NOTE (1) Material designations that are color pigmented may be followed by suffix letters and numbers. (2) Material designations may be prefixed by "ZYT" or "MIN".

UL94 small-scale test data does not pertain to building materials, furnishings and related contents. UL 94 small-scale test data is intended solely for determining the flammability of plastic materials used in components and parts of end-product devices and appliances, where the acceptability of the combination is determined by ULI.