

Type 2012

Globe valve, pneumatically operated

Actuator sizes 175 mm and 225 mm, Nominal diameter DN65 to DN100

Kolbengesteuertes Geradsitzventil

Antriebsgrößen 175 mm und 225 mm, Nennweiten DN65 bis DN100

Vanne à siège droit commandée par piston

Tailles d'actionneur 175 mm et 225 mm, Diamètre nominal DN65 à DN100

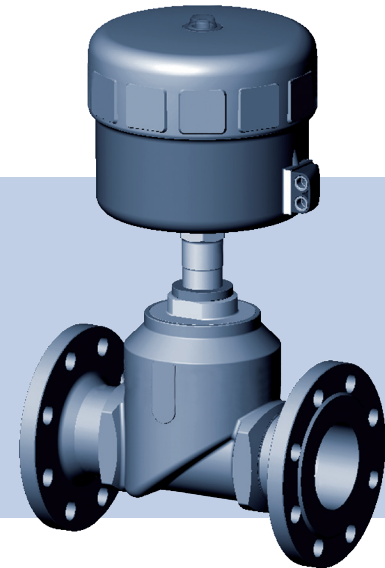

Operating Instructions

Bedienungsanleitung

Manuel d'utilisation

We reserve the right to make technical changes without notice.
Technische Änderungen vorbehalten.
Sous réserve de modifications techniques.

© Bürkert Werke GmbH & Co. KG, 2000 - 2021

Operating Instructions 2102/16_EN-DE-FR_00804396 / Original DE

1	OPERATING INSTRUCTIONS	4	8.2	Before installation.....	12
1.1	Symbols.....	4	8.3	Remove actuator from the valve body (welded connection).....	12
1.2	Definition of the term "device"	4	8.4	Installing valve body.....	12
2	INTENDED USE	5	8.5	Install actuator (welded connection).....	13
3	BASIC SAFETY INSTRUCTIONS	5	8.6	Turning actuator	13
4	GENERAL NOTES	6	8.7	Pneumatic connection.....	14
4.1	Contact addresses	6	8.8	Disassembly	14
4.2	Warranty.....	6	9	MAINTENANCE, CLEANING	15
4.3	Information on the Internet	6	9.1	Safety instructions.....	15
5	PRODUCT DESCRIPTION	7	9.2	Maintenance work	15
5.1	General description	7	9.3	Replacing the valve seat	16
6	STRUCTURE AND FUNCTION	7	10	FAULTS	17
6.1	Structure.....	7	11	SPARE PARTS	18
6.2	Function.....	8	11.1	Replacement part set	18
7	TECHNICAL DATA	9	11.2	Overview of replacement part sets	18
7.1	Conformity.....	9	12	TRANSPORTATION, STORAGE, DISPOSAL	19
7.2	Standards	9			
7.3	Type label	9			
7.4	Operating conditions.....	10			
7.5	Control functions	11			
7.6	Mechanical data.....	11			
8	INSTALLATION	11			
8.1	Safety instructions.....	11			

1 OPERATING INSTRUCTIONS

The operating instructions describe the entire life cycle of the device. Keep these instructions in a location which is easily accessible to every user and make them available to every new owner of the device.

Important safety information!

Failure to observe these instructions may result in hazardous situations.

- ▶ The operating instructions must be read and understood.

1.1 Symbols



DANGER!

Warns of an immediate danger.

- ▶ Failure to observe these instructions will result in death or serious injuries.



WARNING!

Warns of a potentially hazardous situation.

- ▶ Failure to observe these instructions may result in serious injuries or death.



CAUTION!

Warns of a potential danger.

- ▶ Failure to observe these instructions may result in moderate or minor injuries.

NOTE!

Warns of damage.

- ▶ Failure to observe these instructions may result in damage to the device or the system.



Indicates important additional information, tips and recommendations.



Refers to information in these operating instructions or in other documentation.

- ▶ Designates instructions to avoid a danger.

→ Highlights a procedure which you must carry out.

1.2 Definition of the term "device"

The term "device" used in these instructions always refers to the Type 2012 piston-operated globe valve.

In these instructions, the unit bar stands for relative pressure. The absolute pressure is stated separately in bar (abs).

2 INTENDED USE

Non-intended use of the device may be dangerous to people, nearby equipment and the environment.

The Type 2012 device is designed to control the flow of liquid and gaseous media.

- ▶ In potentially explosive environments, the device must only be used in accordance with the specifications on the separate Ex-type label. The additional information and safety instructions relating to Ex areas enclosed with the device must be adhered to when deploying the device.
- ▶ Devices without a separate Ex type label must not be used in the potentially explosive atmosphere.
- ▶ When using the device, observe the authorised data, operating conditions and deployment conditions specified in the contract documents and in the operating instructions. These are described in Chapter [“Technical data”](#).
- ▶ Use the device only in conjunction with third-party devices and components recommended or approved by Bürkert.
- ▶ Prerequisites for safe and trouble-free operation are correct transport, correct storage and installation as well as careful operation and maintenance.
- ▶ Use the device only as intended.

3 BASIC SAFETY INSTRUCTIONS

These safety instructions do not take account of any:

- Contingencies or events which may occur during installation, operation and maintenance of the devices.
- Local safety regulations that are within the operator’s scope of responsibility, including those relating to the installation personnel.



High pressure danger!

- ▶ Before loosening lines or valves, switch off the pressure and bleed the lines.

Danger due to electric voltage.

- ▶ Before accessing the device or the system, switch off the power supply and secure it to prevent reactivation!
- ▶ Observe the applicable accident prevention regulations and safety regulations for electrical devices.

Risk of injury when opening the actuator.

The actuator contains a spring under tension. The spring that ejects when the actuator opens may cause injuries.

- ▶ The actuator must not be opened.

Risk of injury due to moving parts in the device.

- ▶ Do not reach into openings.

Risk of burns.

The device surface can become hot during continuous operation.

- ▶ Do not touch the device with your bare hands.

General hazardous situations.

To prevent injuries, ensure that:

- ▶ The system cannot be activated unintentionally.
- ▶ Installation and maintenance may be performed by authorised technicians only and with the appropriate tools.
- ▶ The process must be restarted in a defined or controlled manner after an interruption in the power supply or pneumatic supply.
- ▶ The device may be operated only when in perfect condition and in consideration of the operating instructions.
- ▶ The general rules of technology must be followed for application planning and operation of the device.

Please observe the following in order to protect against damage to the device:

- ▶ Feed only those media listed in chapter "7 Technical data" into the medium ports.
- ▶ Do not place the valve under mechanical stress (e.g. by placing objects on it or standing on it).
- ▶ Do not make any external modifications to the valves.
- ▶ Do not paint housing parts or screws.

4 GENERAL NOTES

4.1 Contact addresses

Germany

Bürkert Fluid Control Systems
Sales Centre
Christian-Bürkert-Str. 13–17
D-74653 Ingelfingen
Tel. +49 (0) 7940 - 10 91 111
Fax +49 (0) 7940 - 10 91 448
E-mail: info@burkert.com

International

The contact addresses can be found on the back pages of the printed operating instructions.

They are also available online at: www.burkert.com

4.2 Warranty

A precondition for the warranty is that the Type 2012 globe valve is used as intended in consideration of the specified operating conditions.

4.3 Information on the Internet

Operating instructions and data sheets for Type 2012 can be found online at: www.country.burkert.com

5 PRODUCT DESCRIPTION

5.1 General description

The 2/2-way globe valve Type 2012 is suitable for liquid and gaseous media. Using neutral gases or air (control media), it controls the flow of water, alcohol, oil, fuel, hydraulic fluid, saline solution, lye, organic solvents and vapour (flow media).

One special characteristic of the globe valves are screwed-in seats, which can be replaced when needed.

5.1.1 Restrictions



WARNING!

Risk of injury from pressure surge.

A pressure surge could cause lines and the device to burst. Because of the risk of pressure surge, valves with the flow direction above the seat must not be used for fluid media.

- ▶ Observe the type of flow and type of medium for operating the device.

6 STRUCTURE AND FUNCTION

6.1 Structure

The globe valve consists of a pneumatically actuated piston actuator and a 2/2-way globe valve body.

The actuator is made from PA. The self-adjusting packing gland guarantees a high degree of tightness. The stainless steel valve body facilitates high flow values.

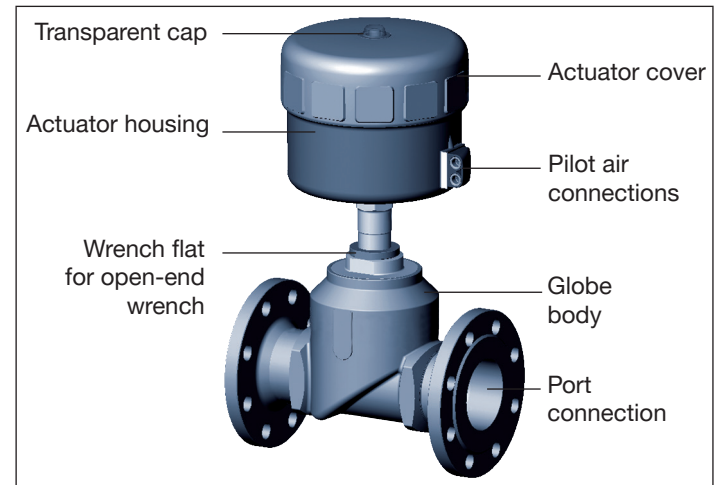

Fig. 1: Type 2012 globe valve, structure and description

6.2 Function

Depending on the variant, the valve seat is closed in the direction of or against the medium flow.

Spring force (CFA) or pneumatic pilot pressure (CFB and CFI) generate the closing force on the swivel plate. A spindle connected to the actuator piston transmits the force.

6.2.1 Control functions (CF)



WARNING!

For control function I – risk of pilot pressure failure.

With control function I, the control unit and reset are pneumatic. No defined position is reached during a pressure failure.

- ▶ To ensure a controlled restart of the device, first apply pilot pressure and then activate the medium.

A (CFA)		Closed by spring force in rest position
B (CFB)		Opened by spring force in rest position
I (CFI)		Actuating function via reciprocal pressurisation

6.2.2 Flow direction below seat

Depending on the variant, the valve is closed against the medium flow either with spring force (control function A, CFA) or pilot pressure (control function B or I, CFB or CFI).

Because the medium pressure is below the swivel plate, it helps open the valve.



WARNING!

Valve leak if there is too little minimum pilot pressure or high medium pressure.

Minimum pilot pressure for CFB and CFI that is too low, or failing to meet the permitted medium pressure, can cause a leak in the valve seat.

- ▶ Adhere to minimum pilot pressure.
- ▶ Do not exceed the medium pressure.
- ▶ Note the pressure ranges in chapter “7.4.2”.

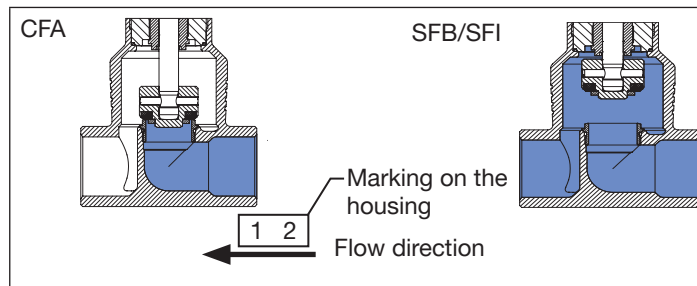

Fig. 2: Flow direction below seat (closing against medium)

6.2.3 Flow direction above the seat

The valve is closed with the medium flow via spring force (control function A, CFA). Because the medium pressure is above the swivel plate, it helps the valve close and also contributes to sealing the valve seat.

The valve opens via pilot pressure.



WARNING!

Risk of injury from pressure surge.

A pressure surge could cause lines and the device to burst. Because of the risk of pressure surge, valves with the flow direction above the seat must not be used for fluid media.

- ▶ Observe the type of flow and type of medium for operating the device.



In order to ensure complete opening, the minimum pilot pressure must be applied.

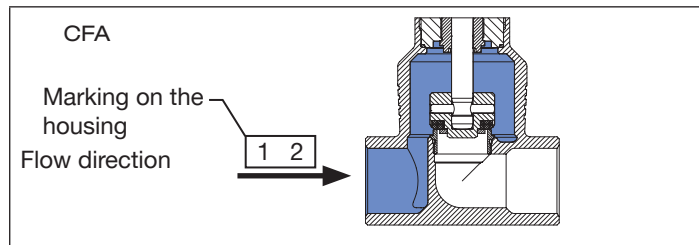

Fig. 3: Flow direction above the seat (closing with the medium)

7 TECHNICAL DATA

7.1 Conformity

The Type 2012 globe valve conforms to the EU directives as per the EU Declaration of Conformity.

7.2 Standards

The applied standards as used to verify compliance with the EU Directives can be found in the EC type examination certificate and/or the EC Declaration of Conformity.

7.3 Type label

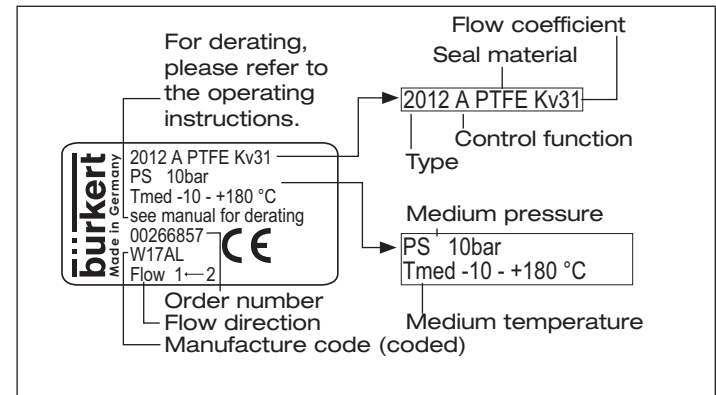

Fig. 4: Description of the type label

7.4 Operating conditions

7.4.1 Temperature ranges

Actuator size [mm]	Actuator material	Medium temperature (with PTFE seal)	Ambient temperature
175, 225	PA	-10 – +180 °C	-10 – +50 °C

7.4.2 Pressure ranges

Actuator material	Actuator size [mm]	Max. Pilot pressure [bar]
PA	175, 225	6

Medium pressure and pilot pressure for control function A, flow direction below seat (standard):

DN	Maximum medium pressure/minimum pilot pressure	
	Actuator size ø [mm]	
	175	225
65	16 (15 *)/4.5	25 (15 *)/3.3
80	10/4.5	16 (12.5 *)/3.3
100	7/4.5	16 (10 *)/4.8

* Medium pressure max. 15 bar according to Pressure Equipment Directive 2014/68/EU for compressible fluids of Group 1 (dangerous gases and vapours according to Art. 4, paragraph (1) c) i) first dash).

Required minimum pilot pressure depending on the medium pressure

In the following graph the required minimum pilot pressure is shown for control functions B and I (only actuator size 175) depending on the medium pressure.

Control function B and I, flow direction below seat *

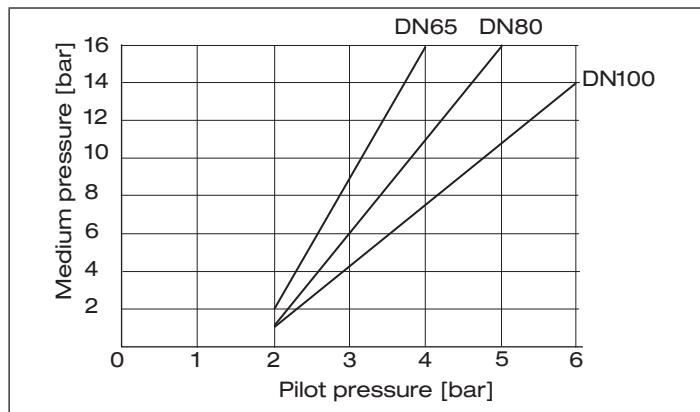

Fig. 5: Pressure diagram, control function B and I, flow direction below seat



Actuator ø 225 is not provided for control function B and I, as the performance data of actuator ø 175 to DN100 are sufficient.

7.4.3 Media

Control media	Neutral gases, air
Flow media	Water, alcohols, oils, fuels, saline solutions, lyes, organic solvents, vapour

7.5 Control functions

Control function A	Closed by spring force in rest position
Control function B	Opened by spring force in rest position
Control function I	Actuating function via reciprocal pressurisation

7.6 Mechanical data

Materials	
Valve body	Stainless steel 316L
Actuator	PA
Seal materials	PTFE (NBR, FKM, EPDM on request)
Packing gland	PTFE (carbon-filled)

8 INSTALLATION

8.1 Safety instructions



DANGER!

Risk of injury from high pressure in the system.

- ▶ Before loosening lines and valves, turn off the pressure and vent the lines.



WARNING!

Risk of injury due to improper installation.

- ▶ Disassembly may be carried out by authorised technicians only and with the appropriate tools.

Risk of injury due to unintentional activation of the system and uncontrolled restart.

- ▶ Secure the system against unintentional activation.
- ▶ Following installation, ensure a controlled restart.

For control function I – risk of pilot pressure failure.

With control function I, the control unit and reset are pneumatic. No defined position is reached during a pressure failure.

- ▶ To ensure a controlled restart of the device, first apply pilot pressure and then activate the medium.

Risk of injury due to moving parts in the device.

- ▶ Do not reach into openings.

8.2 Before installation

Installation position: any, preferably actuator on top.

- Ensure that pipelines are in alignment.
- Note flow direction.
- Remove soiling from pipelines.

8.3 Remove actuator from the valve body (welded connection)

→ Clamp valve body into a holding device.

NOTE!

Damage to the seat seal or seat contour.

- ▶ Valve must be open when uninstalling the actuator.

- For control function A and I: Pressurise pilot air port with compressed air (6 bar): Valve opens.
- Place a suitable open-end wrench on the wrench flat of the nipple and unscrew the actuator from the valve body.
- Do not loosen the screw above the nipple.

8.4 Installing valve body



WARNING!

Risk of injury due to improper installation.

- ▶ Installation may only be performed by qualified and trained personnel.
- ▶ Use an open-end wrench for assembly.
- ▶ Observe tightening torques.

Dirt trap for devices with approval according to DIN EN 161

According to DIN EN 161 "Automatic shut-off valves for gas burners and gas appliances", a dirt trap, which prevents the penetration of a 1 mm test pin, must be installed upstream of the valve.

→ If the approval applies to the valve, such a dirt trap must be attached in front of the globe valve.

Welded connection:

→ Weld or bond valve body in pipeline system.

Other bodies:

→ Connect valve body to pipeline.

8.5 Install actuator (welded connection)

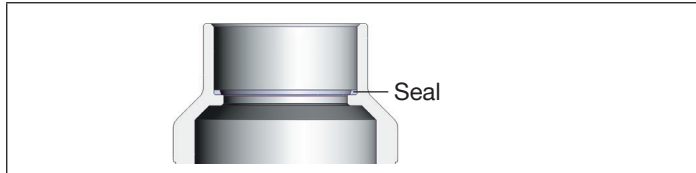

Fig. 6: Seal

→ Check seal and replace if required.

WARNING!

Risk due to incorrect lubricants.

Unsuitable lubricant may contaminate the medium. There is a risk of explosion in oxygen applications.

- ▶ Only used accordingly approved lubricants for specific applications.

→ Before re-installation, grease nipple thread (e.g. using Klüberpaste UH1 96-402 from Klüber).

NOTE!

Damage to the seat seal or seat contour.

- ▶ The valve must be open before installing the actuator.

→ For control functions A and I, pressurise the lower pilot air port with compressed air (6 bar).

→ Screw actuator into the valve body. Note tightening torque as per table 1.

Tightening torques valve body/nipple

DN	65	80	100
Tightening torque (Nm)	100 ± 5	120 ± 5	150 ± 5

Tab. 1: Tightening torques valve body/nipple

8.6 Turning actuator

The position of the ports can be seamlessly aligned by turning the actuator 360°.

NOTE!

Damage to the seat seal or seat contour.

- ▶ The valve must be open when installing the actuator.

→ Clamp valve body in a holding device (only for valves which have not yet been installed).

→ For control functions A and I, pressurise the lower pilot air port with compressed air (6 bar): Valve opens.

→ Counter with a suitable open-end wrench on the wrench flat of the nipple.

WARNING!

Risk of injury from discharge of pressure and escaping medium.

The body connection can loosen when rotated incorrectly.

- ▶ Only turn the actuator in the specified direction.

- Loosen the screw above the nipple by a half rotation and position the actuator as desired by rotating clockwise (seen from above).

→ Reapply the screw (tightening torque 100 ± 5 Nm).

8.7 Pneumatic connection



WARNING!

Risk of injury due to connecting unsuitable hoses.

Hoses that cannot withstand the pressure and temperature range can cause hazardous situations.

- ▶ Only use hoses that are permitted for the specified pressure and temperature range.
- ▶ Note the data sheet information from the hose manufacturers.

For control function I – risk of pilot pressure failure.

With control function I, the control unit and reset are pneumatic. No defined position is reached during a pressure failure.

- ▶ To ensure a controlled restart of the device, first apply pilot pressure and then activate the medium.



If the position of the pilot air ports is unfavourable for installing the hoses, these can be seamlessly aligned by rotating the actuator by 360° (see chapter [“8.6 Turning actuator”](#)).

Control function A:

→ Connect control medium to lower pilot air port.

Control function B:

→ Connect control medium to upper pilot air port.

Control function I:

→ Connect control medium to upper and lower pilot air port.



For usage in an aggressive environment, we recommend using a pneumatic hose to drain all free pneumatic ports in a neutral atmosphere.

Pilot air hose

Pilot air hoses of sizes 6 mm, 4 mm or ¼" can be used.

8.8 Disassembly



DANGER!

Risk of injury from discharge of pressure and escaping medium.

Dismantling a device which is under pressure is hazardous due to a sudden discharge of pressure or escaping medium.

- ▶ Before disassembly, shut off the pressure and vent all lines.

→ Loosen pneumatic connection.

→ Disassemble the device.

9 MAINTENANCE, CLEANING

9.1 Safety instructions



DANGER!

Risk of injury from high pressure in the system.

- ▶ Before loosening lines and valves, turn off the pressure and vent the lines.

Risk of injury due to electric shock.

- ▶ Before reaching into the system, switch off the power supply and secure against reactivation.
- ▶ Observe the applicable accident prevention regulations and safety regulations for electrical devices.



WARNING!

Risk of injury due to improper maintenance work.

- ▶ Maintenance may be carried out by authorised technicians only.
- ▶ Use an open-end wrench, never a pipe wrench, to screw the valve body or actuator in or out, and observe the tightening torque.

Risk of injury due to unintentional activation of the system and uncontrolled restart.

- ▶ Secure the system against unintentional activation.
- ▶ Following maintenance, ensure a controlled restart.

Risk of injury due to moving parts in the device.

- ▶ Do not reach into openings.



WARNING!

For control function I – risk of pilot pressure failure.

With control function I, the control unit and reset are pneumatic. No defined position is reached during a pressure failure.

- ▶ To ensure a controlled restart of the device, first apply pilot pressure and then activate the medium.

9.2 Maintenance work

Actuator:

When used in accordance with these operating instructions, the actuator of the globe valve is maintenance-free.

Wearing parts of the globe valve:

Parts which are subject to natural wear are:

- Valve seat,
- Seals.

→ If there is a leak, replace the respective wearing part with a corresponding spare part.

Visual inspection:

According to the usage conditions, perform regular visual inspections:

- Check medium ports for tightness.
- Check relief bore on the pipe for leaks.

9.2.1 Cleaning

Commercially available cleaning agents can be used to clean the outside.

NOTE!

Avoid causing damage with cleaning agents.

- ▶ Before cleaning, check that the cleaning agents are compatible with body materials and seals.

9.3 Replacing the valve seat

Removing actuator from the valve body

- Clamp valve body into a holding device.

NOTE!

Damage to the seat seal or seat contour.

- ▶ Valve must be open when uninstalling the actuator.

- For control function A and I: Pressurise pilot air port with compressed air (6 bar): Valve opens.
- Place a suitable open-end wrench on the wrench flat of the nipple.
- Unscrew actuator from the valve body.

Replacing valve seat

- Select tool insert and screw it into the assembly tool.
- Unscrew the old valve seat with the assembly tool and a wrench.
- Clean the thread and seal surface in the body with compressed air.
- Attach a new valve seat to the seat assembly tool.
- Lubricate the thread (e.g. Klüberpaste UH1 96-402).
- Manually screw the attached valve seat into the body thread.
- Tighten to the specified tightening torque with a torque wrench (see “[Tab. 2](#)”).

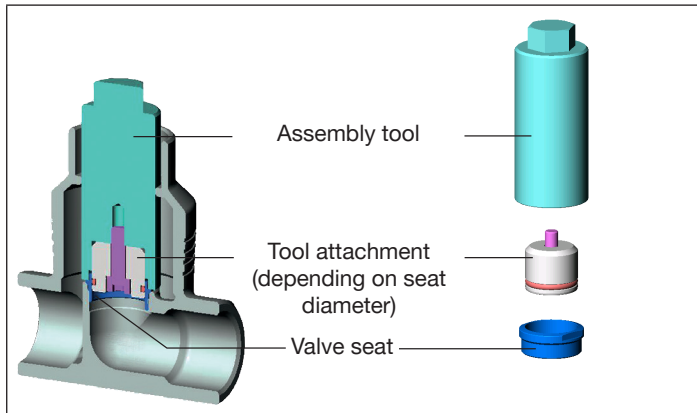

Fig. 7: Replacing the valve seat

Tightening torque values for seat assembly

Fitting		Tightening torques [Nm]		Tolerance
Valve seat	Housing	Uncoated valve seats	Coated valve seats	
DN65	DN65	150	150	+10
DN80	DN80	180	180	+10
DN100	DN100	220	220	+10

Tab. 2: Tightening torque values for seat assembly

10 FAULTS

Fault	Cause	Elimination
Actuator does not switch	Pilot air port interchanged	Connect lower (CFA, CFI) or upper (CFB, CFI) pilot air port
	Pilot pressure too low	Observe pressure specifications on the type label
	Medium pressure too high	Observe pressure specifications on the type label
Valve is not tight	Flow direction interchanged	Observe direction of arrow on the type label
	Dirt between seal and valve seat	Install dirt trap
	Valve seat seal worn	Replace valve seat seal
	Flow direction interchanged	Observe direction of arrow on the type label
Valve is leaking on the relief bore	Medium pressure too high	Observe pressure specifications on the type label
	Pilot pressure too low	Observe pressure specifications on the type label
Valve is leaking on the relief bore	Packing gland worn	Replace packing gland or actuator

Tab. 3: Faults

11 SPARE PARTS



CAUTION!

Risk of injury and/or damage due to incorrect parts.

Incorrect accessories and unsuitable spare parts may cause injuries and damage the device and the area around it.

- ▶ Use only original accessories and original spare parts from Bürkert.

11.1 Replacement part set

The following replacement part sets are available for the globe valve Type 2012:

- Seal set for packing gland,
- Valve set,
- Valve set (valve unit + seat),
- Seal set for swivel plate



The order numbers of the spare parts and the installation instructions are available in the operating instructions for spare parts on our homepage:

www.country.burkert.com → Type 2012

11.2 Overview of replacement part sets

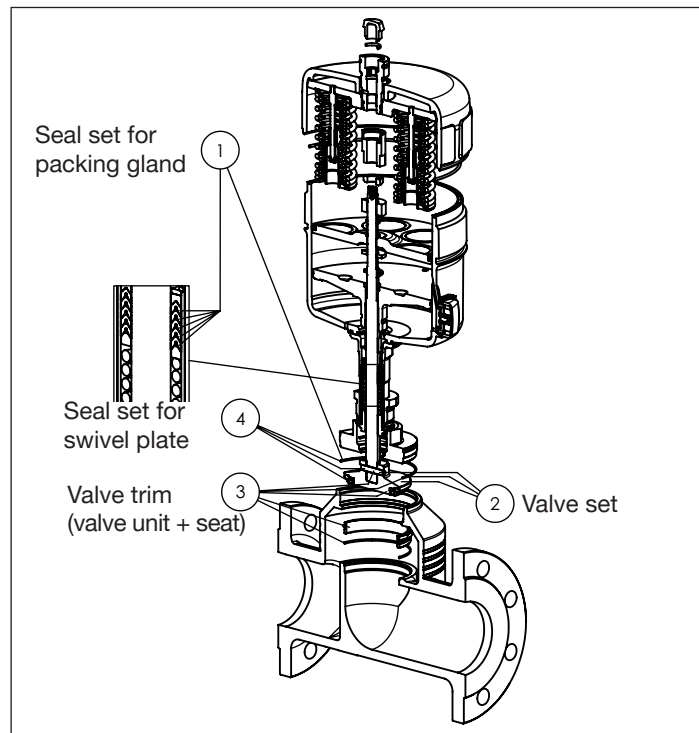

Fig. 8: Overview of replacement part sets

12 TRANSPORTATION, STORAGE, DISPOSAL

NOTE!

Transport damage.

Inadequately protected devices may be damaged during transport.

- ▶ Protect the device against moisture and dirt in shock-resistant packaging during transport.
- ▶ Avoid exceeding or dropping below the permitted storage temperature.

Incorrect storage may damage the device.

- ▶ Store the device in a dry and dust-free location.
- ▶ Storage temperature $-20 - +65$ °C.

Damage to the environment caused by device parts contaminated with media.

- ▶ Dispose of the device and packaging in an environmentally friendly manner.
- ▶ Observe applicable disposal and environmental regulations.



Note:

Observe national waste disposal regulations.

www.burkert.com