

## Type S020

Insertion fitting  
Insertion Fitting  
Raccord à insertion



## Operating Instructions

Bedienungsanleitung  
Manuel d'utilisation

We reserve the right to make technical changes without notice.  
Technische Änderungen vorbehalten.  
Sous réserve de modifications techniques.

© Bürkert SAS, 2012 - 2020

Operating Instructions 2003/08\_EU-ML 00565449 ORIGINAL\_FR

<b>1. ABOUT THE OPERATING INSTRUCTIONS</b> .....	<b>5</b>		
1.1. Symbols used.....	5		
1.2. Definition of the term product.....	5		
<b>2. INTENDED USE</b> .....	<b>6</b>		
<b>3. BASIC SAFETY INFORMATION</b> .....	<b>6</b>		
<b>4. GENERAL INFORMATION</b> .....	<b>7</b>		
4.1. Manufacturer's address and international contacts.....	7		
4.2. Warranty conditions.....	7		
4.3. Information on the Internet.....	7		
<b>5. TECHNICAL DATA</b> .....	<b>8</b>		
5.1. Conditions of use.....	8		
5.2. Conformity to standards and directives.....	8		
5.3. Conformity to the Pressure Equipment Directive.....	8		
5.4. Dimensions .....	9		
5.5. Diameters available.....	9		
5.6. Materials .....	10		
5.7. K factors.....	10		
5.7.1. Terms of reference .....	10		
5.7.2. Calculation of K factors (in pulse/litre) for saddles, fusion spigots, welding sockets with radius or screw-ons.....	10		10
5.7.3. K factors (in pulse/litre) for T fittings used with a 8041 or 8045 with a G2" nut .....	12		12
5.7.4. K factors (in pulse/litre) for T fittings and wel- ding sockets used with a 8041 or a 8045 with clamp connection.....	15		15
5.7.5. K factors (in pulse/litre) for T fittings used with a 8020, 8024, 8025 or 8026 .....	15		15
5.7.6. K factors (in pulse/litre) for saddles.....	18		18
5.7.7. K factors (in pulse/l) of the fusion spigots and welding sockets with radius for measuring devices with a G2" nut.....	19		19
5.7.8. K factors (in pulse/litre) for screw-ons.....	21		21
<b>6. INSTALLATION AND COMMISSIONING</b> .....	<b>22</b>		
<b>6.1. Safety instructions</b> .....	<b>22</b>		
<b>6.2. Installation onto the pipe</b> .....	<b>23</b>		
6.2.1. Recommendations for installing the product on the pipe.....	23		23
6.2.2. Installing a T fitting .....	25		25
6.2.3. Installing saddles.....	26		26
6.2.4. Installing a welding socket with radius, for mea- suring devices with a G2" nut .....	27		27
6.2.5. Installing a welding socket, for measuring devices with a clamp connection .....	27		27

6.2.6. Installing a fusion spigot (PE, PP or PVDF) .....	30
6.2.7. Installing a screw-on in plastic (PP, PVC, PE) .....	30
6.2.8. Installing the measurement chamber .....	31
6.2.9. Graph - pipe DN - fluid velocity - flow rate.....	32
<b>7. MAINTENANCE.....</b>	<b>33</b>
<b>7.1. Safety instructions.....</b>	<b>33</b>
<b>7.2. Cleaning .....</b>	<b>33</b>
<b>8. SPARE PARTS AND ACCESSORIES .....</b>	<b>33</b>
<b>9. PACKAGING, TRANSPORT, STORAGE.....</b>	<b>37</b>
<b>10. DISPOSAL OF THE PRODUCT.....</b>	<b>37</b>

# 1. ABOUT THE OPERATING INSTRUCTIONS

The Operating Instructions describe the entire life cycle of the product. Please keep the Operating Instructions in a safe place, accessible to all users and any new owners.

### The Operating Instructions contain important safety information.

Failure to comply with these instructions can lead to hazardous situations. Pay attention in particular to the chapters [3. Basic safety information](#) and [2. Intended use](#).

- ▶ Irrespective of the product version, the Operating Instructions must be read and understood.

## 1.1. Symbols used



### DANGER

**Warns against an imminent danger.**

- ▶ Failure to observe this warning can result in death or in serious injury.



### WARNING

**Warns against a potentially dangerous situation.**

- ▶ Failure to observe this warning can result in serious injury or even death.



### ATTENTION

**Warns against a possible risk.**

- ▶ Failure to observe this warning can result in substantial or minor injuries.

### NOTICE

**Warns against material damage.**



Indicates additional information, advice or important recommendations.



Refers to information contained in these Operating Instructions or in other documents.

- ▶ Indicates an instruction to be carried out to avoid a danger, a warning or a possible risk.

→ Indicates a procedure to be carried out.

## 1.2. Definition of the term product

The term "product" used in these Operating Instructions always refers to the Type S020 fitting or to the Type S020 measuring chamber.

## 2. INTENDED USE

**Use of the product that does not comply with the instructions could present risks to people, nearby installations and the environment.**

The Type S020 fitting is intended for the installation of insertion measuring devices in a pipe.

The Type S020 measuring chamber is intended on the one hand, to install a measuring device in a pipe and, on the other hand, to guarantee that the measurement sensor of the measuring device is fully covered by the fluid.

- ▶ Use the product in compliance with the specifications and conditions of commissioning and use given in the contractual documents, in the Operating Instructions of the product and in the Operating Instructions of the combined instrument.
- ▶ Store, transport, install and operate the product properly.
- ▶ Only operate a product in perfect working order.
- ▶ Only use this product as intended.

## 3. BASIC SAFETY INFORMATION

This safety information does not take into account any contingencies or occurrences that may arise during installation, use and maintenance of the product.

The local safety regulations for which the operating company is responsible including the staff in charge of installation and maintenance.



- Risk of injury due to high pressure in the installation.**
- Risk of burns due to high temperatures of the fluid.**
- Risk of injury due to the nature of the fluid.**



### **Various dangerous situations**

- ▶ Prevent any unintentional power supply switch-on.
- ▶ Ensure that installation and maintenance work are carried out by qualified, authorised personnel in possession of the appropriate tools.
- ▶ Guarantee a set or controlled restarting of the process, after a power supply interruption.
- ▶ Use the product only if in perfect working order and in compliance with the instructions provided in the Operating Instructions.



#### Various dangerous situations (cont'd)

- ▶ Observe the general technical rules when installing and using the product.
- ▶ Do not use the product in explosive atmospheres.
- ▶ Do not use fluid that is incompatible with the materials from which the product is made.
- ▶ Do not use the product in an environment incompatible with the materials from which it is made.
- ▶ Do not subject the product to mechanical loads.
- ▶ Do not make any modifications to the product.

#### NOTICE

##### The product may be damaged by the measured fluid

- ▶ Systematically check the chemical compatibility of the component materials of the product and the fluids likely to come into contact with the materials (for example: alcohols, strong or concentrated acids, aldehydes, alkaline compounds, esters, aliphatic compounds, ketones, halogenated aromatics or hydrocarbons, oxidants and chlorinated agents).

## 4. GENERAL INFORMATION

### 4.1. Manufacturer's address and international contacts

To contact the manufacturer of the product, use following address:

Bürkert SAS

Rue du Giessen

BP 21

F-67220 TRIEMBACH-AU-VAL

The addresses of our international branches can be found on the Internet at: [www.burkert.com](http://www.burkert.com)

### 4.2. Warranty conditions

The condition governing the legal warranty is the conforming use of the product in observance of the operating conditions specified in the Operating Instructions.

### 4.3. Information on the Internet

You can find the Operating Instructions and the technical data sheet for Type S020 at: [www.burkert.com](http://www.burkert.com)

## 5. TECHNICAL DATA

### 5.1. Conditions of use

<b>Fluid temperature</b>	depends on the inserted measuring device and the material from which the Type S020 fitting is made. Refer to the Operating Instructions for the measuring device and to the dependency curve between the fluid temperature and the fluid pressure in Fig. 3. If the ranges are different, use the most restrictive range.
<b>Ambient temperature</b>	depends on the inserted measuring device into the Type S020 fitting. Refer to the related Operating Instructions.
<b>Pressure class</b>	depends on the inserted measuring device and the material from which the Type S020 fitting is made. Refer to the Operating Instructions for the measuring device and to the dependency curve between the fluid temperature and the fluid pressure in Fig. 3. If the pressure classes are different, take the lowest value into account.

### 5.2. Conformity to standards and directives

The applied standards, which verify conformity with the EU Directives, can be found on the EU Type Examination Certificate and/or the EU Declaration of Conformity (if applicable).

### 5.3. Conformity to the Pressure Equipment Directive

→ Make sure that the device / product materials are compatible with the fluid.

→ Make sure that the pipe DN is adapted for the product.

The product conforms to Article 4, Paragraph 1 of the Pressure Equipment Directive 2014/68/EU under the following conditions:

- Product used on a pipe (PS = maximum admissible pressure in bar; DN = nominal dimension of the pipe, no unit)

Type of fluid	Conditions
Fluid group 1, Article 4, Paragraph 1.c.i	DN ≤ 25
Fluid group 2, Article 4, Paragraph 1.c.i	DN ≤ 32 or PSxDN ≤ 1000 bar
Fluid group 1, Article 4, Paragraph 1.c.ii	DN ≤ 25 or PSxDN ≤ 2000 bar
Fluid group 2, Article 4, Paragraph 1.c.ii	DN ≤ 200 or PS ≤ 10 bar or PSxDN ≤ 5000 bar



- Product used on a vessel (PS = maximum admissible pressure in bar; V = vessel volume in L)

Type of fluid	Conditions
Fluid group 1, Article 4, Paragraph 1.a.i	V > 1 L and PSxV ≤ 25 bar.L OR PS ≤ 200 bar
Fluid group 2, Article 4, Paragraph 1.a.i	V > 1 L and PSxV ≤ 50 bar.L OR PS ≤ 1000 bar
Fluid group 1, Article 4, Paragraph 1.a.ii	V > 1 L and PSxV ≤ 200 bar.L OR PS ≤ 500 bar
Fluid group 2, Article 4, Paragraph 1.a.ii	PS > 10 bar and PSxV ≤ 10000 bar.L OR PS ≤ 1000 bar

## 5.4. Dimensions

Refer to the related datasheet at [www.burkert.com](http://www.burkert.com)

## 5.5. Diameters available

The diameters available depend on the design of the Type S020 fitting.



Refer to the technical data sheets for the Type S020 fittings and the inserted measuring device to determine:

- the appropriate DN.
- the fitting suitable for the physical quantity to be measured.

Table 1: Diameters available depending on the design of the fitting

Design of the S020	DN available
T fittings for measuring devices with a G2" nut	DN6 to DN65
T fittings for measuring devices with a clamp process connection	DN32 to DN100
Welding socket with radius, for measuring devices with a G2" nut	DN50 to DN350
Plastic fusion spigot	DN65 to DN400
Screw-on <sup>1)</sup>	DN100 to DN400
Welding socket for measuring devices with clamp connection	DN32 to DN100
Saddle <sup>1)</sup>	DN50 to DN200

<sup>1)</sup> Only for the flow measurement.

## 5.6. Materials

Table 2: Materials depending on the design of the Type S020 fitting

Design of the S020	Materials		
	Body	Adapter	Seal
T fittings for measuring devices with a G2" nut	Stainless steel (316L - 1.4404)	Stainless steel (316L - 1.4404)	FKM or EPDM
	Brass		
	PVC		
	PP		
	PVDF		
T fittings for measuring devices with a clamp process connection	Stainless steel (316L)	-	-
Welding socket with radius, for measuring devices with a G2" nut	Stainless steel (316L - 1.4404)	-	-
Fusion spigot	PE	-	-
	PP	-	-
	PVDF	-	-
Welding socket for measuring devices with clamp connection	Stainless steel (316L)	-	-

Design of the S020	Materials		
	Body	Adapter	Seal
Screw-on	PVC	-	-
	PE	-	-
	PP	-	-
Saddle	PP	PVC or PP	EPDM
Measurement chamber	Stainless steel (316L - 1.4404)	-	-

## 5.7. K factors

### 5.7.1. Terms of reference

The K factors have all been determined under the following terms of reference: fluid = water, water and room temperatures of 20°C, minimum upstream and downstream distances respected, appropriate pipe dimensions.

### 5.7.2. Calculation of K factors (in pulse/litre) for saddles, fusion spigots, welding sockets with radius or screw-ons



The calculation does not apply to T fittings or welding sockets for measuring devices with a clamp connection.

In addition to the terms of reference mentioned above, the K factors for saddles, fusion spigots, welding sockets with radius and screw-ons have been determined as a function of the external diameter ( $D_{\text{material}}$ ) and the wall thickness ( $s_{\text{material}}$ ) of the pipe given in the tables.

→ When the dimensions of the pipe are slightly different from dimensions **D** and **s** given in the tables, recalculate the K factor using one of the following formulae:



These formulae can only be applied if the dimensions of the pipe vary by +/-5% compared with the theoretical dimensions given in the tables.

$$K_n = K_t \times \frac{d_t^2}{d_n^2}$$

Fig. 1: Fitting used with a paddle-wheel flowmeter

$$K_n = K_t \times \frac{d_n^2}{d_t^2}$$

Fig. 2: Fitting used with an electromagnetic flowmeter

$K_n$  = recalculated K factor

$K_t$  = K factor given in the table

$d_t = D_{\text{material}} - 2s_{\text{material}}$  = theoretical internal diameter of the pipe calculated using the values  $D_{\text{material}}$  and  $s_{\text{material}}$  given in the tables, for each fitting material ( $D_{\text{material}}$  = external diameter of the pipe and  $s_{\text{material}}$  = wall thickness of the pipe)

$d_n$  = internal diameter of the pipe

### 5.7.3. K factors (in pulse/litre) for T fittings used with a 8041 or 8045 with a G2" nut

! We advise not to use a type 8041 or 8045 measuring device in an Type S020 fitting in brass and with a DN strictly lower than DN20 because drifts in measurement may occur.

! If the measuring device does not automatically convert the K factor, use the following conversion formulae before setting the parameters of the measuring device:

- K factor in pulse/US gallon = K factor in pulse/litre x 3.785
- K factor in pulse/UK gallon = K factor in pulse/litre x 4.546

! Two versions of the Type S020 in DN15 and DN20 exist, having different K factors.

Only version 2, identified by the "v2" marking, is available from March 2012. The "v2" marking can be found:

- on the bottom of the DN15 fitting in plastic:



- on the side of the DN15 or DN20 fitting in metal:

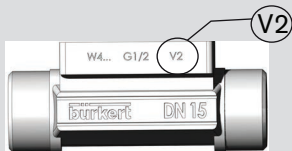



The names of the following norms have changed in the Operating Instructions:

- for the welding ends, norm BS 4825 is renamed BS 4825-1.
- for the clamp connections, norm BS 4825 is renamed BS 4825-3.
- for the flange connections, norm EN 1092-1 (ISO PN16) is renamed EN 1092-1 / B1 / PN16.



- The norm ISO for clamp connections is replaced through the norm DIN 32676 series B.
- The norm DIN 32676 series A for clamp connections is added.

Table 3: K factors of the T fittings used with a 8041 or 8045 with G2" nut

Material	Type of connection and standard	K factor [Pulse/litre]											
		DN6	DN8	DN15	DN15 v2	DN20	DN20 v2	DN25	DN32	DN40	DN50	DN65	
Stainless steel	welding ends acc. to												
	▪ SMS 3008	-	-	-	-	-	-	1,98	-	4,32	6,68	11,3	
	▪ to DIN 11866 series C / BS 4825-1 / ASME BPE	-	-	-	-	1,69	1,75	1,98	2,85	4,32	6,68	11,3	
	▪ DIN 11866 series B / EN ISO 1127 / ISO 4200	-	-	1,69	1,75	1,98	-	2,85	4,32	6,68	11,3	-	
Stainless steel	external threads												
	▪ acc. to SMS 1145	-	-	-	-	-	-	1,98	-	4,32	6,68	-	
	▪ G	0,355	0,530	1,69	1,75	1,98	-	2,85	4,32	6,68	11,3	-	
Stainless steel	internal threads												
	▪ G, Rc, NPT	0,355	0,530	1,69	1,75	1,98	-	2,85	4,32	6,68	11,3	-	

Material	Type of connection and standard	K factor [Pulse/litre]											
		DN6	DN8	DN15	DN15 v2	DN20	DN20 v2	DN25	DN32	DN40	DN50	DN65	
Stainless steel	clamp acc. to												
	▪ SMS 3017	-	-	-	-	-	-	1,98	-	4,32	6,68	11,3	
	▪ BS 4825-3 / ASME BPE	-	-	-	-	1,69	1,75	1,98	-	4,32	6,68	11,3	
	▪ DIN 32676 series A	-	-	-	-	1,69	1,75	1,98	2,85	4,32	6,68	11,3	
	▪ DIN 32676 series B	-	-	1,69	1,75	1,98	-	2,85	4,32	6,68	11,3	-	
Stainless steel	flanges acc. to												
	▪ EN 1092-1 / B1 / PN16												
	▪ ANSI B16-5	-	-	1,69	1,75	1,98	-	2,85	4,32	6,68	11,3	-	
	▪ JIS 10K												
Brass	all	-	-	-	-	1,98	-	2,85	4,32	6,68	11,3	-	
PVC	all	0,310	0,470	1,33	1,33	1,45	-	2,26	4,29	7,30	12,5	-	
PP	all	-	-	1,29	1,37	1,44	-	2,21	4,30	7,16	12,2	-	
PVDF	all	-	-	1,21	1,22	1,37	-	2,04	4,03	6,88	11,5	-	

#### 5.7.4. K factors (in pulse/litre) for T fittings and welding sockets used with a 8041 or a 8045 with clamp connection



The norm BS 4825 is renamed BS 4825-1.

Table 4: K factors of the T fittings for measuring devices with clamp connection

Welding ends acc. to	DN40	DN50	DN65	DN80	DN100
SMS 3008	5.23	10.4	15.9	24.7	-
BS 4825-1 / ASME BPE / DIN 11866 series C	5.33	10.4	16.7	25.7	50.3
DIN 11850 series 2 / DIN 11866 series A / EN 10357 series A	6.12	11.2	21	32.8	52.7
ISO 4200 / ISO 1127 / DIN 11866 series B	-	-	-	-	-

#### 5.7.5. K factors (in pulse/litre) for T fittings used with a 8020, 8024, 8025 or 8026



Do not use a Type S020 fitting in sizes DN6, DN8, DN15, DN15 Version 2 (V2) or DN20 Version 2 (V2) with a paddle-wheel flow-meter types 8020, 8024, 8025, 8026.



If the measuring device does not automatically convert the K factor, use the following conversion formulae before setting the parameters of the measuring device:

- K factor in pulse/US gallon = K factor in pulse/litre x 3.785
- K factor in pulse/UK gallon = K factor in pulse/litre x 4.546



Two versions of the Type S020 in DN15 and DN20 exist, having different K factors.

Only version 2, identified by the "v2" marking, is available from March 2012. The "v2" marking can be found:

- on the bottom of the DN15 fitting in plastic:



- on the side of the DN15 or DN20 fitting in metal:

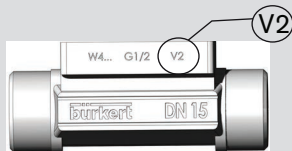

The names of the following norms have changed in the Operating Instructions:

- for the welding ends, norm BS 4825 is renamed BS 4825-1.
- for the clamp connections, norm BS 4825 is renamed BS 4825-3.
- for the flange connections, norm EN 1092-1 (ISO PN16) is renamed EN 1092-1 / B1 / PN16.



- The norm ISO for clamp connections is replaced through the norm DIN 32676 series B.
- The norm DIN 32676 series A for clamp connections is added.



## Type S020

Technical data

Table 5: K factors of the T fittings used with a 8020, 8024, 8025 or 8026

Material	Type of connection and standard	K factor [Pulse/litre]											
		DN6	DN8	DN15	DN15 v2	DN20	DN20 v2	DN25	DN32	DN40	DN50	DN65	
Stainless steel	welding ends acc. to												
	▪ SMS 3008	-	-	-	-	-	-	64,0	-	30,9	19,5	11,2	
	▪ DIN 11866 series C / BS 4825-1 / ASME BPE	-	-	-	-	-	-	64,0	48,3	30,9	19,5	11,2	
	▪ DIN 11866 series B / EN ISO 1127 / ISO 4200	-	-	-	-	64,0	-	48,3	30,9	19,5	11,2	-	
Stainless steel	external threads												
	▪ acc. to SMS 1145	-	-	-	-	-	-	64,0	-	30,9	19,5	-	
	▪ G	-	-	-	-	64,0	-	48,3	30,9	19,5	11,2	-	
Stainless steel	internal threads												
	▪ G, Rc, NPT	-	-	-	-	64,0	-	48,3	30,9	19,5	11,2	-	
Stainless steel	clamp acc. to												
	▪ SMS 3017	-	-	-	-	-	-	64,0	-	30,9	19,5	11,2	
	▪ BS 4825-3 / ASME BPE	-	-	-	-	-	-	64,0	-	30,9	19,5	11,2	
	▪ DIN 32676 series A	-	-	-	-	-	-	64,0	48,3	30,9	19,5	11,2	
	▪ DIN 32676 series B	-	-	-	-	64,0	-	48,3	30,9	19,5	11,2	-	
Stainless steel	flanges acc. to												
	▪ N1092-1 /B1/PN16	-	-	-	-	64,0	-	48,3	30,9	19,5	11,2	-	
	▪ ANSI B16-5	-	-	-	-	64,0	-	48,3	30,9	19,5	11,2	-	
	▪ JIS 10K	-	-	-	-	64,0	-	48,3	30,9	19,5	11,2	-	
Brass	all	-	-	-	-	64,0	-	48,3	30,9	19,5	11,2	-	
PVC	all	-	-	-	-	81,1	-	56,6	29,9	18,6	10,7	-	
PP	all	-	-	-	-	75,1	-	53,6	29,0	17,4	10,3	-	
PVDF	all	-	-	-	-	81,2	-	60,3	31,9	19,4	11,1	-	

### 5.7.6. K factors (in pulse/litre) for saddles

 When the dimensions of the pipe are slightly different from dimensions **D** and **s** given in the table, recalculate the K factor using one of the formulae in chap. 5.7.2.

 If the measuring device does not automatically convert the K factor, use the following conversion formulae before setting the parameters of the measuring device:

- K factor in pulse/US gallon = K factor in pulse/litre x 3.785
- K factor in pulse/UK gallon = K factor in pulse/litre x 4.546

Table 6: K factors, external diameters and pipe wall thicknesses of saddles

Inserted measuring device Material of the pipe DN	8020, 8024, 8025, 8026		8041, 8045		External diameters and wall thicknesses of the pipe			
	PVC	PE / PP	PVC	PE / PP	D <sub>PVC</sub> [mm]	s <sub>PVC</sub> [mm]	D <sub>PE/PP</sub> [mm]	s <sub>PE/PP</sub> [mm]
50	14,2 (L)	15,6 (L)	10,4 (L)	9,28 (L)	63	4,7	63	5,8
65	11,2 (L)	12,3 (L)	14,5 (L)	12,9 (L)	75	5,5	75	6,9
80	7,37 (L)	7,80 (L)	21,3 (L)	20,4 (L)	90	6,6	90	8,2
100	4,83 (L)	5,29 (L)	33,0 (L)	30,4 (L)	110	8,1	110	10
110	3,45 (L)	-	44,7 (L)	-	125	9,2	-	-
125	2,55 (L)	3,10 (L)	63,7 (L)	52,1 (L)	140	10,3	140	12,8
150	1,67 (L)	2,03 (L)	137 (L)	78,8 (L)	160	6,2	160	14,6
180	1,08 (L)	1,37 (L)	197 (L)	116 (L)	200	9,6	200	18,2
200	0,80 (L)	1,07 (L)	290 (L)	147 (L)	225	8,6	225	20,5

(L): long sensor version

### 5.7.7. K factors (in pulse/l) of the fusion spigots and welding sockets with radius for measuring devices with a G2" nut

**!** When the dimensions of the pipe are slightly different from dimensions **D** and **s** given in the table, recalculate the K factor using one of the formulae in chap. 5.7.2.

**!** If the measuring device does not automatically convert the K factor, use the following conversion formulae before setting the parameters of the measuring device:

- K factor in pulse/US gallon = K factor in pulse/litre x 3.785
- K factor in pulse/UK gallon = K factor in pulse/litre x 4.546

Table 7: K factors, external diameters and pipe wall thicknesses of the welding sockets with radius, for measuring devices with a G2" nut, and of the fusion spigots in plastic, used with a 8020, 8024, 8025 or 8026

Inserted measuring device Material of the pipe	8020, 8024, 8025, 8026			External diameters and wall thicknesses of the pipe					
	Stainless steel	PE / PP	PVDF	D <sub>steel</sub> [mm]	s <sub>steel</sub> [mm]	D <sub>PE/PP</sub> [mm]	s <sub>PE/PP</sub> [mm]	D <sub>PVDF</sub> [mm]	s <sub>PVDF</sub> [mm]
DN									
50	13,0 (C)	-	-	60,3	2,0	-	-	-	-
65	7,86 (C)	8,32 (C)	5,53 (C)	76,1	2,9	75	6,9	75	2,5
80	5,52 (C)	5,49 (C)	3,65 (C)	88,9	3,2	90	8,2	90	2,8
100	3,20 (C)	3,51 (C)	2,34 (C)	114,3	3,6	110	10	110	3,5
110	-	-	-	-	-	-	-	-	-
125	2,00 (C)	2,66 (L)	-	139,7	4	140	12,8	-	-
150	1,32 (C)	2,12 (L)	-	168,3	4,5	160	14,6	-	-
180	-	-	-	-	-	200	18,2	-	-
200	0,72 (C)	0,98 (L)	-	219,1	6,3	225	20,5	-	-
250	0,50 (L)	0,63 (L)	-	273	7,7	280	25,5	-	-
300	0,35 (L)	0,42 (L)	-	323,9	9,5	315	28,7	-	-
350	0,26 (L)	0,30 (L)	-	355,6	10,1	355	32,3	-	-
400	-	0,23 (L)	-	-	-	400	36,4	-	-

Table 8: K factors, external diameters and pipe wall thicknesses of welding sockets with radius and fusion spigots, in plastic, used with a 8041 or a 8045 with G2" nut

Inserted measuring device	8041, 8045 with sensor in stainless steel			8041, 8045 with sensor in PVDF			External diameters and wall thicknesses of the pipe					
	Material of the pipe	Stainless steel	PE / PP	PVDF	Stainless steel	PE / PP	PVDF	D <sub>steel</sub> [mm]	s <sub>steel</sub> [mm]	D <sub>PE/PP</sub> [mm]	s <sub>PE/PP</sub> [mm]	D <sub>PVDF</sub> [mm]
DN	Stainless steel	PE / PP	PVDF	Stainless steel	PE / PP	PVDF	D <sub>steel</sub> [mm]	s <sub>steel</sub> [mm]	D <sub>PE/PP</sub> [mm]	s <sub>PE/PP</sub> [mm]	D <sub>PVDF</sub> [mm]	s <sub>PVDF</sub> [mm]
50	11,6 (C)	-	-	13,8 (C)	-	-	60,3	2,0	-	-	-	-
65	20,0 (C)	17,8 (C)	24,1 (C)	24,0 (C)	21,3 (C)	28,9 (C)	76,1	2,9	75	6,9	75	2,5
80	28,5 (C)	25,6 (C)	40,8 (C)	33,2 (C)	30,7 (C)	48,9 (C)	88,9	3,2	90	8,2	90	2,8
100	49,2 (C)	38,1 (C)	70,5 (C)	60,5 (C)	45,7 (C)	84,5 (C)	114,3	3,6	110	10	110	3,5
110	-	-	-	-	-	-	-	-	-	-	-	-
125	78,0 (C)	81,7 (L)	-	93,6 (C)	81,7 (L)	-	139,7	4	140	12,8	-	-
150	98,4 (C)	103 (L)	-	118 (C)	103 (L)	-	168,3	4,5	160	14,6	-	-
180	-	-	-	-	-	-	-	-	200	18,2	-	-
200	210 (C)	224 (L)	-	252 (C)	224 (L)	-	219,1	6,3	225	20,5	-	-
250	311 (L)	347 (L)	-	311 (L)	347 (L)	-	273	7,7	280	25,5	-	-
300	447 (L)	510 (L)	-	447 (L)	510 (L)	-	323,9	9,5	315	28,7	-	-
350	609 (L)	705 (L)	-	609 (L)	705 (L)	-	355,6	10,1	355	32,3	-	-
400	-	931 (L)	-	-	931 (L)	-	-	-	400	36,4	-	-

(C): short sensor version

(L): long sensor version

### 5.7.8. K factors (in pulse/litre) for screw-ons

 When the dimensions of your pipe are slightly different from dimensions **D** and **s** given in the table, recalculate the K factor using one of the formulae in chap. 5.7.2.

 If the measuring device does not automatically convert the K factor, use the following conversion formulae before setting the parameters of the measuring device:

- K factor in pulse/US gallon = K factor in pulse/litre x 3.785
- K factor in pulse/UK gallon = K factor in pulse/litre x 4.546

Table 9: K factors, external diameters and pipe wall thicknesses of screw-ons

Inserted measuring device Material of the pipe DN	8020, 8024, 8025, 8026		8041, 8045		External diameters and wall thicknesses of the pipe			
	PVC	PP / PE	PVC	PP / PE	D <sub>PVC</sub> [mm]	s <sub>PVC</sub> [mm]	D <sub>PE/PP</sub> [mm]	s <sub>PE/PP</sub> [mm]
100	4,83 (L)	5,29 (L)	33,0 (L)	30,4 (L)	110	8,1	110	10
110	3,45 (L)	-	44,7 (L)	-	125	9,2	125	11,4
125	2,55 (L)	3,10 (L)	63,7 (L)	52,1 (L)	140	10,3	140	12,8
150	1,67 (L)	2,12 (L)	137 (L)	78,8 (L)	160	6,2	160	14,6
180	1,08 (L)	1,37 (L)	197 (L)	116 (L)	200	9,6	200	18,2
200	0,80 (L)	1,07 (L)	290 (L)	147 (L)	225	8,6	225	20,5
250	-	0,63 (L)	-	347 (L)	-	-	280	25,5
300	-	0,42 (L)	-	510 (L)	-	-	315	28,7
350	-	0,30 (L)	-	705 (L)	-	-	355	32,3
400	-	0,23 (L)	-	931 (L)	-	-	400	36,4

(L): long sensor version

## 6. INSTALLATION AND COMMISSIONING

### 6.1. Safety instructions



#### **DANGER**

##### **Risk of injury due to high pressure in the installation.**

- ▶ Stop the circulation of fluid, cut off the pressure and drain the pipe before loosening the process connections.

##### **Risk of burns due to high fluid temperatures.**

- ▶ Do not touch with bare hands the parts of the product that are in contact with the fluid.
- ▶ Stop the circulation of fluid and drain the pipe before loosening the process connections.

##### **Risk of injury due to the nature of the fluid.**

- ▶ Respect the prevailing regulations on accident prevention and safety relating to the use of dangerous fluids.



#### **WARNING**

##### **Risk of injury due to non-conforming installation.**

- ▶ Fluid installation must only be carried out by qualified and authorised personnel with the appropriate tools.
- ▶ Observe the installation instructions for the measuring device inserted into the product.



#### **WARNING**

##### **Risk of injury due to an uncontrolled restart.**

- ▶ Ensure that the restart of the installation is controlled after any interventions on it.

##### **Risk of injury if the fluid pressure / temperature dependency is not respected.**

- ▶ Take into account the dependency between the fluid pressure and the fluid temperature according to the materials from which the product is made (see Fig. 3) and to the measuring device used (see the related Operating Instructions).
- ▶ Observe the Pressure Equipment Directive 2014/68/EU.



#### **WARNING**

##### **Danger due to non-conforming commissioning.**

Non-conforming commissioning may lead to injuries and damage the product and its surroundings.

- ▶ Before commissioning, make sure that the staff in charge have read and fully understood the contents of the Operating Instructions.
- ▶ In particular, observe the safety recommendations and intended use.
- ▶ The installation must only be commissioned by suitably trained staff.

## Type S020

### Installation and commissioning

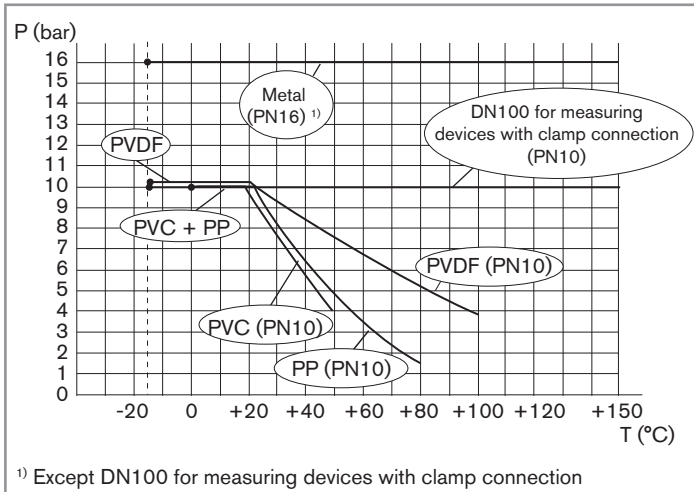

Fig. 3: Fluid pressure / fluid temperature dependency curves for T fittings used on their own

## 6.2. Installation onto the pipe

### 6.2.1. Recommendations for installing the product on the pipe

→ To measure the pH or the oxidation reduction potential, install a U-shaped bypass in order to prevent the electrode drying out and to allow calibration without stopping the process.

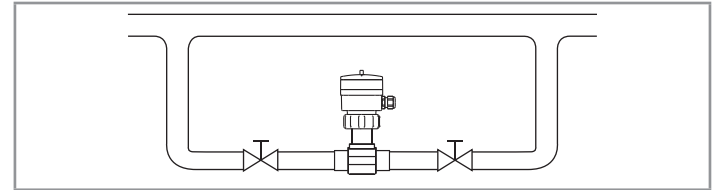

Fig. 4: Bypass installation of the product

→ For measuring the flow, install the product upstream a valve or any equipment that changes the pipe diameter or the pipe direction. If the recommendation cannot be complied with, install the product in the pipe in such a way that the straight downstream distances are satisfied depending on the design of the pipes, refer to standard EN ISO 5167-1 and [Fig. 5](#).

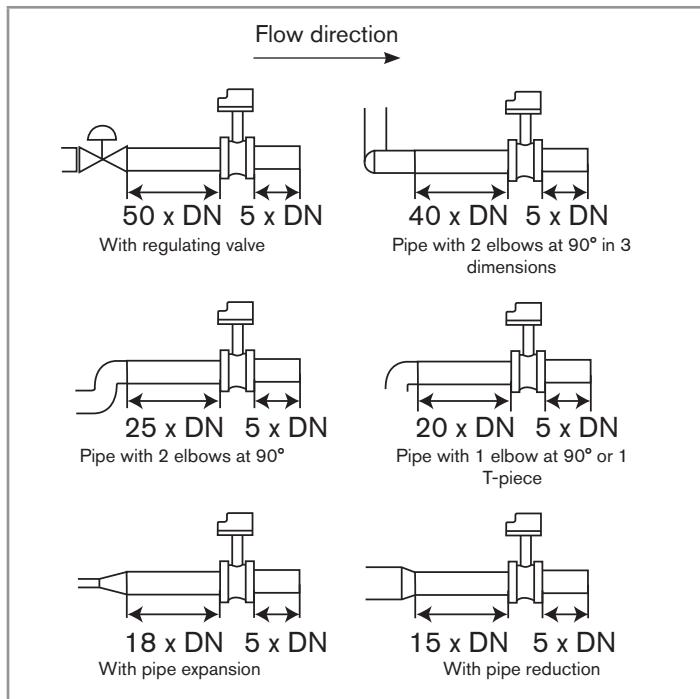

Fig. 5: Upstream and downstream distances depending on the design of the pipes.

→ For measuring the flow, use a flow conditioner, if necessary, to obtain the best accuracy.

→ For all types of measurement, respect the following additional assembly conditions to ensure that the measuring device operates correctly:

- Prevent the formation of air bubbles in the pipe in the section around the measuring device (Fig. 6).
- Ensure that the pipe is always filled in the section around the measuring device (Fig. 7).

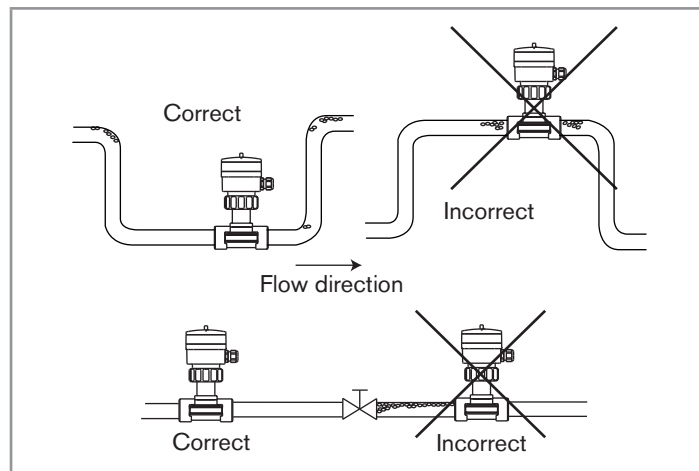

Fig. 6: Air bubbles in the pipe



## Type S020

### Installation and commissioning

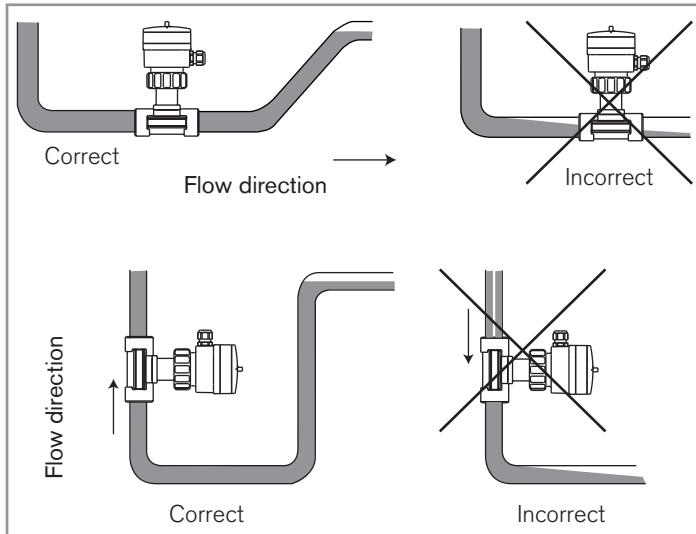

Fig. 7: Filling of the pipe

### 6.2.2. Installing a T fitting



Follow the recommendations on installation described in chap. 6.2.1.

#### NOTICE

**The seal on the fitting with welding end connections may be damaged during welding.**

Version for measuring devices with a G2" nut:

- ▶ Before welding the welding ends, remove the adapter from the fitting by unscrewing the 4 screws and remove the seal.
- ▶ After welding, correctly put the seal in the groove and the adapter on the fitting, tighten the 4 screws, applying a nominal tightening torque of 2 N·m.

Version for measuring devices with a clamp connection:

- ▶ Before welding the welding ends, remove the seal.
- ▶ After welding, correctly replace the seal in the groove.

→ Install the fitting by turning one of the polarizing slots opposite the flow direction.

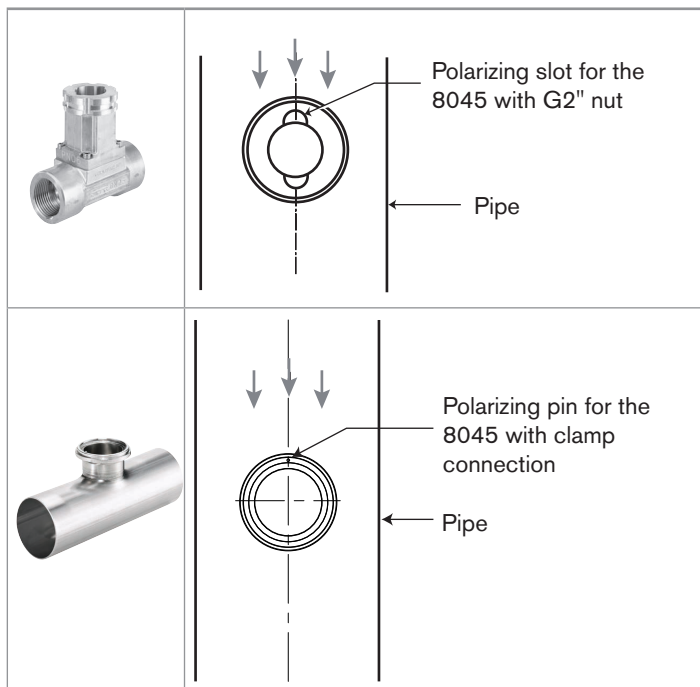

Fig. 8: Installing a T fitting

### 6.2.3. Installing saddles

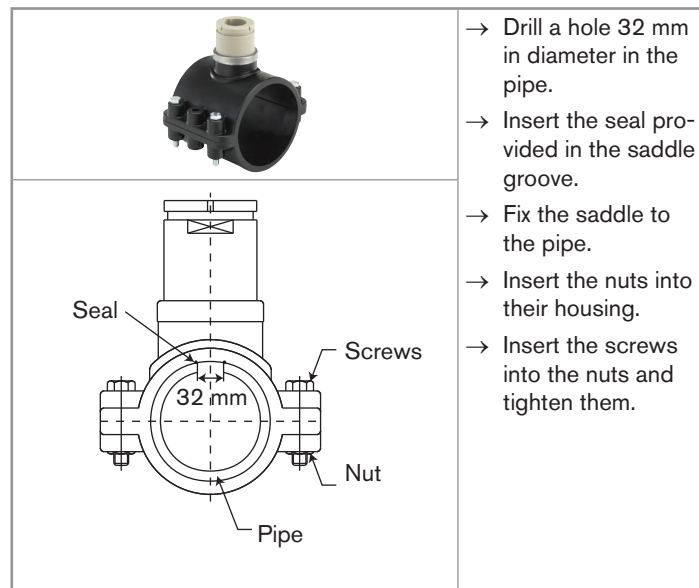

Fig. 9: Installing saddles

- Drill a hole 32 mm in diameter in the pipe.
- Insert the seal provided in the saddle groove.
- Fix the saddle to the pipe.
- Insert the nuts into their housing.
- Insert the screws into the nuts and tighten them.

## Type S020

Installation and commissioning

### 6.2.4. Installing a welding socket with radius, for measuring devices with a G2" nut

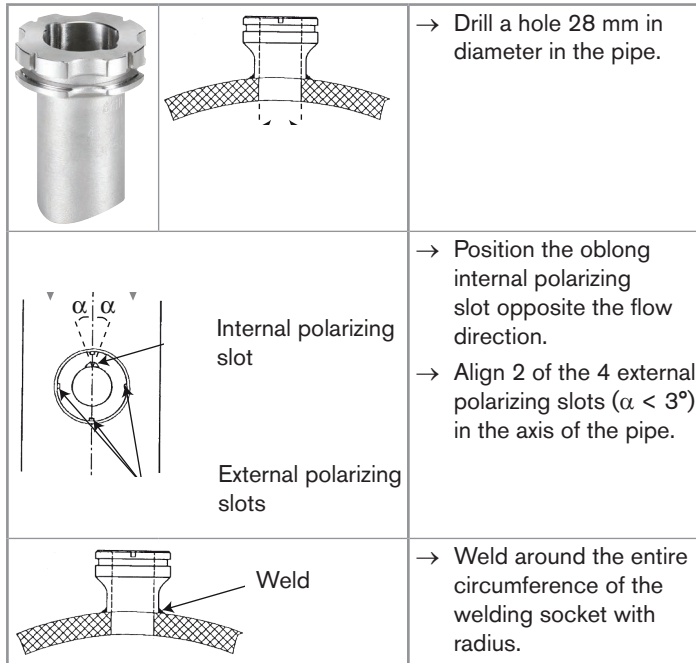

Fig. 10: Installing a welding socket with radius

### 6.2.5. Installing a welding socket, for measuring devices with a clamp connection



In the Operating Instructions, norm BS 4825 is renamed BS 4825-1.

The welding socket can be installed:

- either on a T fitting with a short branch, installed into the pipe,
  - or on the pipe which has previously been drilled and extruded to shape a T fitting with a short branch.
- Respect the dimensions in [Table 10](#) to drill and extrude the pipe.

Table 10: Dimensions to drill and extrude the pipe

DN	Standard	H	D
32	ISO 4200 / ISO 1127 / DIN 11866 series B		38.4
40	SMS 3008	3.0	35.6
	BS 4825-1 / ASME BPE / DIN 11866 series C	2.5	34.8
	DIN 11850 series 2 / DIN 11866 series A / EN 10357 series A	3.0	38
	ISO 4200 / ISO 1127 / DIN 11866 series B		38.4
50	SMS 3008	3.0	35.6
	BS 4825-1 / ASME BPE / DIN 11866 series C	2.5	34.8
	DIN 11850 series 2 / DIN 11866 series A / EN 10357 series A	3.5	38
	ISO 4200 / ISO 1127 / DIN 11866 series B		38.4

DN	Standard	H	D
65	SMS 3008	3.0	35.6
	BS 4825-1 / ASME BPE / DIN 11866 series C	4.0	34.8
	DIN 11850 series 2 / DIN 11866 series A / EN 10357 series A	4.0	38
	ISO 4200 / ISO 1127 / DIN 11866 series B		38.4
80	SMS 3008	4.0	35.6
	BS 4825-1 / ASME BPE / DIN 11866 series C	4.5	34.8
	DIN 11850 series 2 / DIN 11866 series A / EN 10357 series A	4.5	38
	ISO 4200 / ISO 1127 / DIN 11866 series B		38.4
100	SMS 3008		1) <sup>1)</sup>
	BS 4825-1 / ASME BPE / DIN 11866 series C	5.5	34.8
	DIN 11850 series 2 / DIN 11866 series A / EN 10357 series A	6.5	38

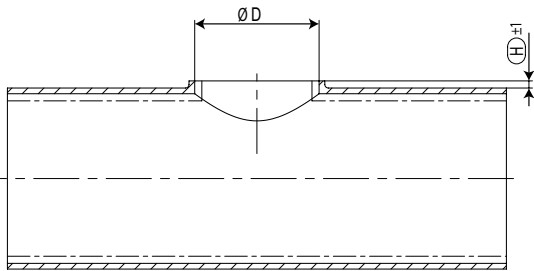

1) Depending on the pipe, refer to line BS 4825-1 / ASME BPE / DIN 11866 series C or to line DIN 11850 series 2 / DIN 11866 series A / EN 10357 series A of DN100

→ Make sure length L corresponds to the DN and standard of the socket used, if not the K factors given in [5.7.4](#) are not correct.

Table 11: Length L to respect

DN	L	Standards
32	-	ISO 4200 / ISO 1127 / DIN 11866 series B
40	23.5	SMS 3008
	24.6	BS 4825-1 / ASME BPE / DIN 11866 series C
	23.8	DIN 11850 series 2 / DIN 11866 series A / EN 10357 series A
	-	ISO 4200 / ISO 1127 / DIN 11866 series B
50	23.8	SMS 3008
	25.2	BS 4825-1 / ASME BPE / DIN 11866 series C
	24.3	DIN 11850 series 2 / DIN 11866 series A / EN 10357 series A
	-	ISO 4200 / ISO 1127 / DIN 11866 series B
65	22.6	SMS 3008
	23.6	BS 4825-1 / ASME BPE / DIN 11866 series C
	24.6	DIN 11850 series 2 / DIN 11866 series A / EN 10357 series A
	-	ISO 4200 / ISO 1127 / DIN 11866 series B

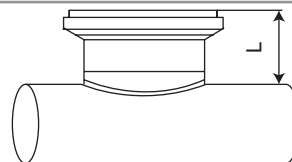

## Type S020

### Installation and commissioning

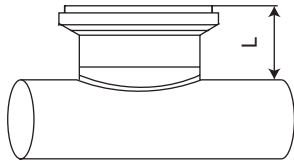

DN	L	Standards
80	23.0	SMS 3008
	23.9	BS 4825-1 / ASME BPE / DIN 11866 series C
	24.8	DIN 11850 series 2 / DIN 11866 series A / EN 10357 series A
	-	ISO 4200 / ISO 1127 / DIN 11866 series B
100	1)	SMS 3008
	23.0	BS 4825-1 / ASME BPE / DIN 11866 series C
	25.1	DIN 11850 series 2 / DIN 11866 series A / EN 10357 series A

1) Depending on the pipe, refer to line BS 4825-1 / ASME BPE / DIN 11866 series C or to line DIN 11850 series 2 / DIN 11866 series A / EN 10357 series A of DN100

→ Install the welding socket on the pipe as shown in Fig. 11.

<p>Marking of the flow direction</p> <p>Polarizing pin</p> <p>Flow direction</p>	<p>→ Position the polarizing pin opposite the flow direction.</p>
<p><math>\alpha</math></p> <p><math>\alpha</math></p> <p>Polarizing pin</p>	<p>→ Align the polarizing pin (<math>\alpha &lt; 3^\circ</math>) in the axis of the pipe.</p>
	<p>→ Tip 4 points at <math>90^\circ</math> from each other.</p> <p>→ Weld around the entire circumference of the welding socket.</p>

Fig. 11: Installing a welding socket, for measuring devices with a clamp connection

### 6.2.6. Installing a fusion spigot (PE, PP or PVDF)

	<p>→ Drill a hole 40 mm in diameter in the pipe.</p>
 <p>Internal polarizing slot</p> <p>External polarizing slots</p>	<p>→ Position the oblong internal polarizing slot opposite the flow direction.</p> <p>→ Align 2 of the 4 external polarizing slots (<math>\alpha &lt; 3^\circ</math>) in the axis of the pipe.</p>
 <p>Weld</p>	<p>→ Weld around the entire circumference of the fusion spigot.</p>

Fig. 12: Installing a fusion spigot (PE, PP or PVDF)

### 6.2.7. Installing a screw-on in plastic (PP, PVC, PE)

	 <p>G 1-1/2"</p> <p><math>\phi</math> 45</p>	<p>→ Drill a hole 45 mm in diameter in the pipe.</p> <p>→ Thread to G 1 1/2".</p>
 <p>G 1-1/2"</p>	<p>→ Screw on the spigot until it reaches length L (see Table 12) corresponding to the DN of the pipe so that the K factors given in Table 9 are respected.</p> <p>→ Use an appropriate sealing material (PTFE tape, for example).</p>	
 <p>Internal polarizing slot</p> <p>External polarizing slots</p>	<p>→ When L is reached, slightly unscrew or continue to screw until 2 of the 4 polarizing slots are aligned in the axis of the pipe and the oblong internal polarizing slot is positioned opposite the flow direction.</p>	

Fig. 13: Installing a screw-on (PP, PVC, or PE)

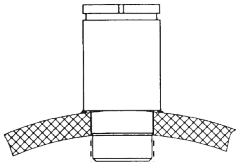
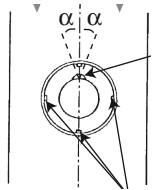
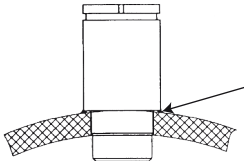
## Type S020

### Installation and commissioning

Table 12: Lengths L to be screwed to insert Type 8020, 8024, 8025, 8026, 8041 and 8045 flowmeters, depending on the material of the screw-on

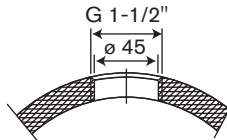
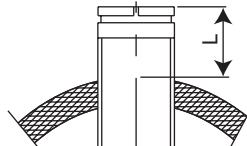
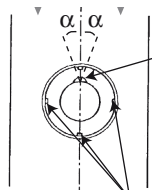
DN of the screw-on	Length L to be screwed (in mm)	
	PVC	PP / PE
100	69.3	
110	57.8	-
125	57.3	57
150	57.3	57
180	61.3	61.3
200	60.8	60.8
250	-	53.6
300	-	47.5
350	-	40.7
400	-	32.9

### 6.2.8. Installing the measurement chamber

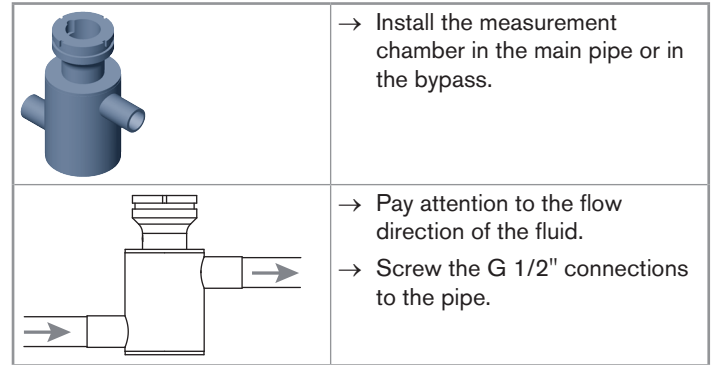
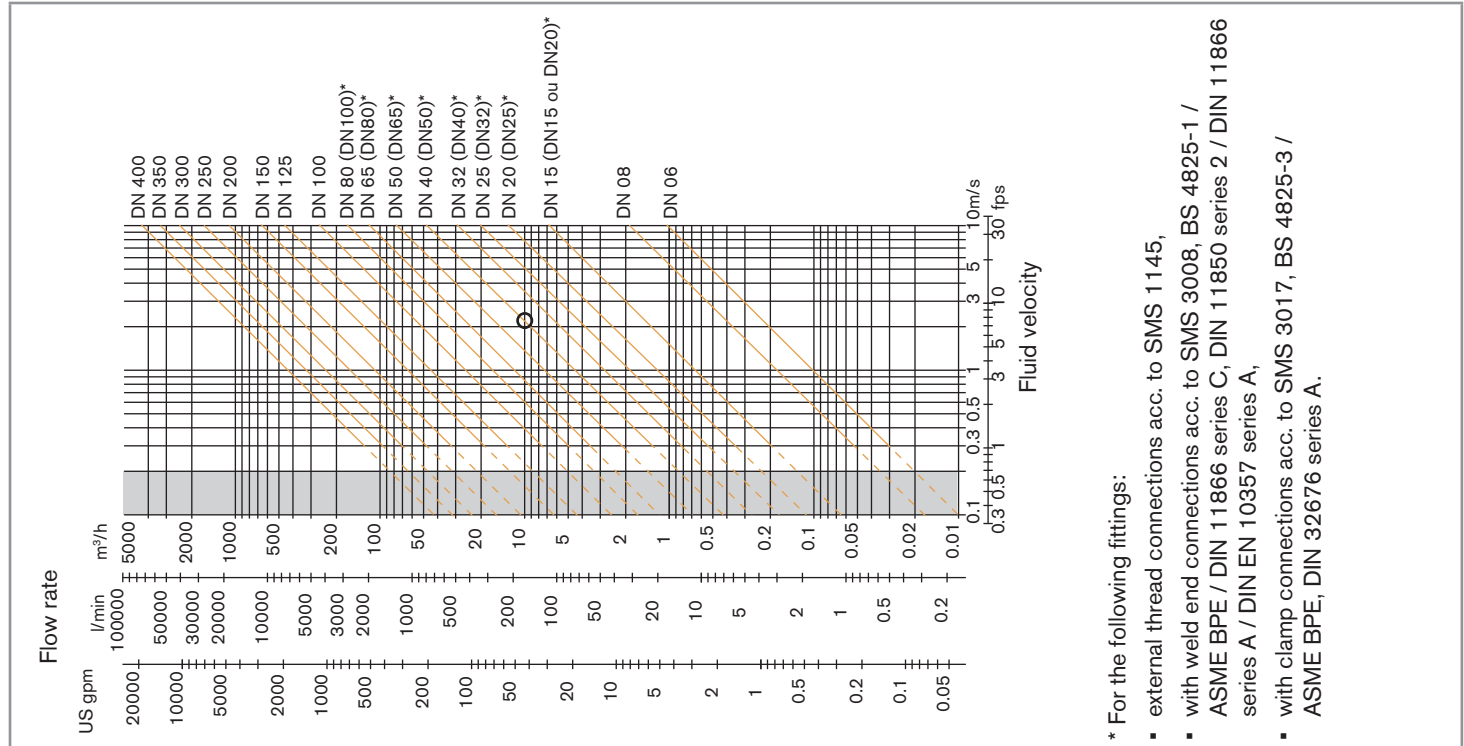

Fig. 14: Installing the measurement chamber

### 6.2.9. Graph - pipe DN - fluid velocity - flow rate

The graph is used to determine the DN of the pipe and the fitting appropriate to the application, according to the fluid velocity and the flow rate.



\* For the following fittings:

- external thread connections acc. to SMS 1145,
- with weld end connections acc. to SMS 3008, BS 4825-1 / ASME BPE / DIN 11866 series C, DIN 11850 series 2 / DIN 11866 series A / DIN EN 10357 series A,
- with clamp connections acc. to SMS 3017, BS 4825-3 / ASME BPE, DIN 32676 series A.



## 7. MAINTENANCE

### 7.1. Safety instructions



#### DANGER

##### Risk of injury due to high pressure in the installation.

- ▶ Stop the circulation of fluid, cut off the pressure and drain the pipe before loosening the process connections.

##### Risk of burns due to high fluid temperatures.

- ▶ Do not touch with bare hands the parts of the product that are in contact with the fluid.
- ▶ Stop the circulation of fluid and drain the pipe before loosening the process connections.
- ▶ Keep all easily flammable fluid or material away from the product.

##### Risk of injury due to the nature of the fluid.

- ▶ Respect the prevailing regulations on accident prevention and safety relating to the use of dangerous fluids.



#### WARNING

##### Risk of injury due to non-conforming maintenance.

- ▶ Maintenance must only be carried out by qualified and skilled staff with the appropriate tools.
- ▶ Ensure that the restart of the installation is controlled after any intervention.

## 7.2. Cleaning

### NOTICE

The product may be damaged by the cleaning solution.

- ▶ Clean the product with a cloth dampened with water or a detergent compatible with the materials the product is made of.

## 8. SPARE PARTS AND ACCESSORIES



#### ATTENTION

Risk of injury and/or damage caused by the use of unsuitable parts.

Incorrect accessories and unsuitable spare parts may cause injuries and damage the product and the surrounding area.

- ▶ Use only original accessories and original spare parts from Bürkert.

Accessory	Order code
<b>Certificate</b>	
Inspection certificate 3.1 acc. to EN 10204 (S020 in stainless steel)	<b>803723</b>
Test report 2.2 acc. to EN 10204	<b>803722</b>
Certificate with the surface finish value	<b>804175</b>
3-point calibration certificate (S020 combined with the flowmeter inserted)	<b>550676</b>
FDA approval	<b>803724</b>

→ For any certificate, contact your Burkert sales subsidiary.

Spare part	Order code
<b>Adapter (with 4 screws)</b> (Fig. 15)	
in stainless steel	<b>555484</b>
in PVC	<b>561175</b>
in PP	<b>561176</b>
in PVDF	<b>561177</b>
<b>Set of O-ring seals (DN6 to DN65) for adapter in stainless steel</b>	
FKM (5 parts)	<b>428971</b>
EPDM (5 parts)	<b>428972</b>

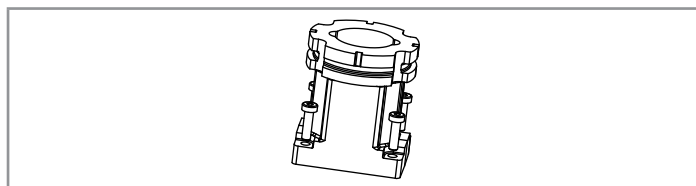

Fig. 15: Adapter with 4 screws

Spare part	Order code
<b>Set of seals (DN6 to DN65) for adapter in plastic</b> (Fig. 16)	
FKM (1 O-ring seal and 1 flat seal)	<b>561043</b>
EPDM (1 O-ring seal and 1 flat seal)	<b>561044</b>

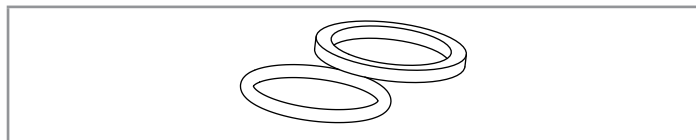

Fig. 16: Set of seals for adapter in plastic

**Type S020**  
Maintenance

Spare part	Order code
<b>Plug fitted with an O-ring seal in FKM, nut in PC and snap ring (all DN<sub>s</sub>) (Fig. 17)</b>	
in stainless steel	<b>438755</b>
in PVC	<b>438754</b>
in PP	<b>627614</b>

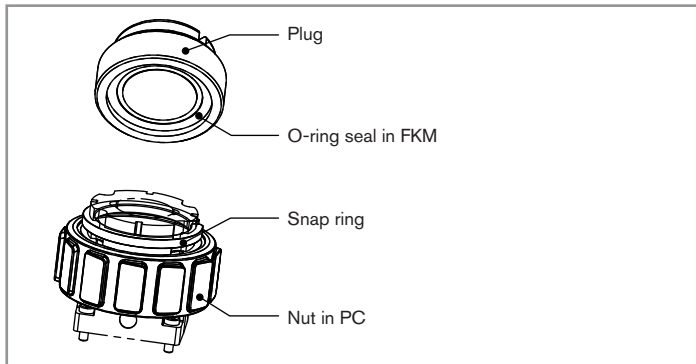

Fig. 17: Plug with O-ring seal, nut and snap ring

Spare part	Order code
O-ring seal in EPDM with FDA agreement, for a T fitting or a welding socket for measuring devices with a clamp connection (see Fig. 18)	<b>730837</b>
O-ring seal in FEP with FDA agreement, for a T fitting or a welding socket for measuring devices with a clamp connection (see Fig. 18)	<b>730839</b>

Spare part	Order code
Clamp (see Fig. 18)	<b>731164</b>
Plug for T fittings or welding sockets for measuring devices with a clamp connection (see Fig. 18)	<b>565200</b>

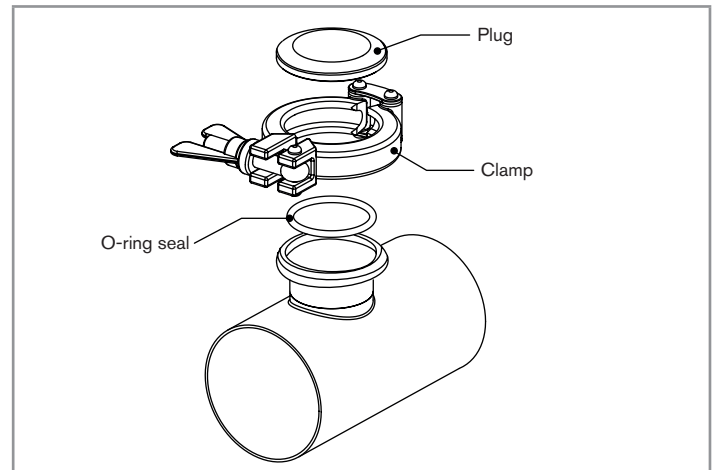
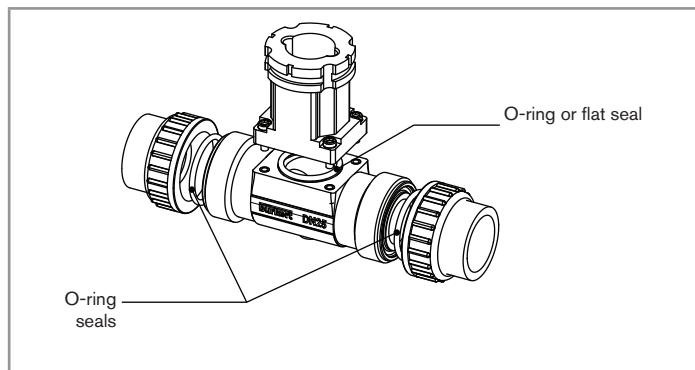

Fig. 18: Plug, clamp and seal for an S020 for measuring devices with a clamp connection

Spare part	Order code
<b>Set of 2 O-ring seals for the end pieces + 1 flat seal and 1 O-ring seal for the adapter (T fittings with true union connection only) (Fig. 19)</b>	
FKM - DN8	<b>448679</b>
FKM - DN15	<b>431555</b>
FKM - DN20	<b>431556</b>
FKM - DN25	<b>431557</b>
FKM - DN32	<b>431558</b>
FKM - DN40	<b>431559</b>
FKM - DN50	<b>431560</b>
EPDM - DN8	<b>448680</b>
EPDM - DN15	<b>431561</b>
EPDM - DN20	<b>431562</b>
EPDM - DN25	<b>431563</b>
EPDM - DN32	<b>431564</b>
EPDM - DN40	<b>431565</b>
EPDM - DN50	<b>431566</b>



*Fig. 19: Seals for a fitting with true union connection*

## 9. PACKAGING, TRANSPORT, STORAGE

### NOTICE

#### **Damage due to transport**

Transport may damage an insufficiently protected part.

- ▶ Transport the product in shock-resistant packaging and away from humidity and dirt.
- ▶ Do not expose the product to temperatures that may exceed the admissible storage temperature range.

#### **Poor storage can damage the product.**

- ▶ Store the product in a dry place away from dust.
- ▶ Storage temperature of the product:  $-15...+60^{\circ}\text{C}$ .

## 10. DISPOSAL OF THE PRODUCT

→ Dispose of the product and its packaging in an environmentally-friendly way.

### NOTICE

#### **Damage to the environment caused by parts contaminated by the fluid.**

- ▶ Comply with the national and/or local regulations which concern the area of waste disposal.





[www.burkert.com](http://www.burkert.com)