

SUPER HEAVY DUTY BATTERY

R6P

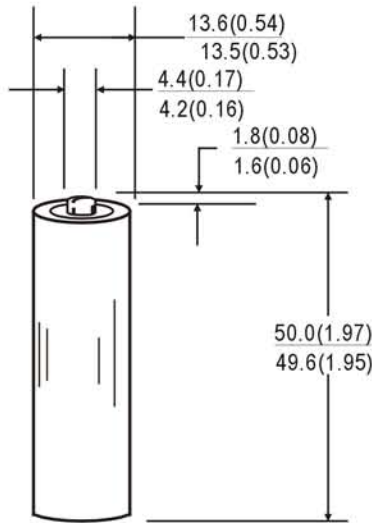

Unit: mm(inch)

Chemical System : Zinc -Manganese Dioxide
(Zinc Chloride Electrolyte)

CONRAD Art. Number : 650046, 650022,650250,650619

IEC No. : R6

ANSI/NEDA No. : 15D (AA)

Average Weight : 18g

Dimension(\varnothing x H) : $13.6^{+0.1}$ x $49.8^{+0.2}$ mm

$0.54^{+0.004}$ x $1.96^{+0.008}$ inch

Terminals : Flat

Nominal Voltage : 1.5Volts

Average Capacity : 1220mAh to 0.8 volts

(At $20 \pm 2^\circ\text{C}$, Rated capacity at 25 mA continuous drain)

Jacket : PVC

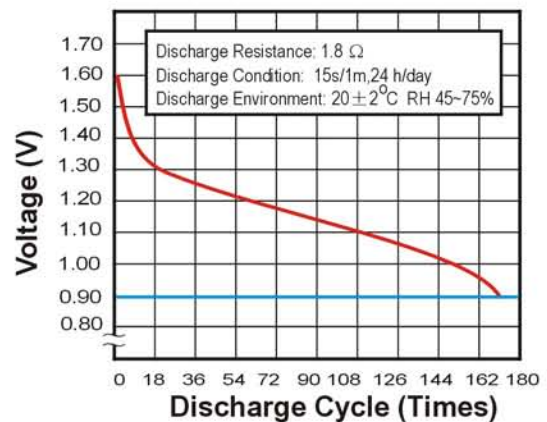
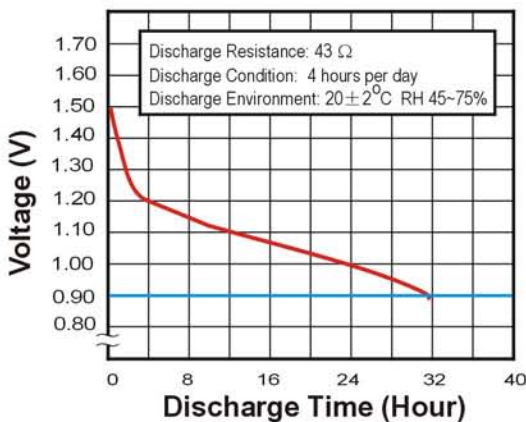
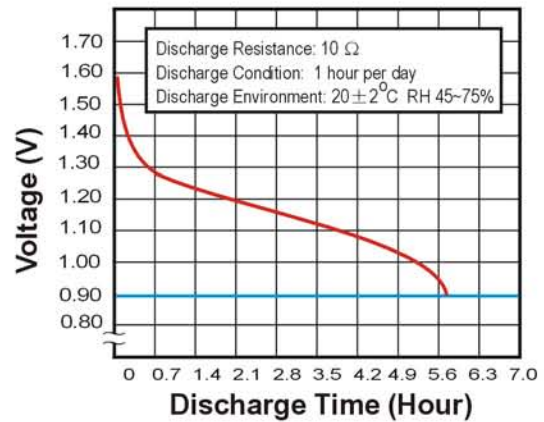
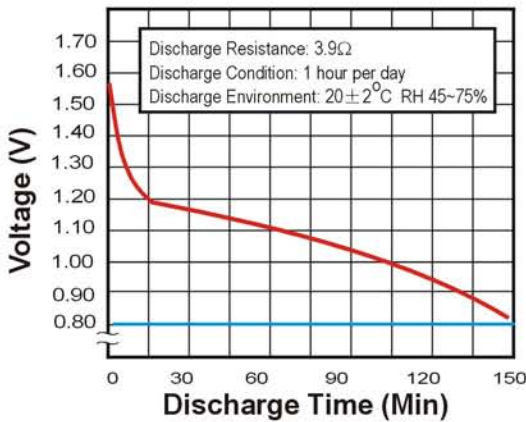

Notice:

Environmental elements comply with RoHS requirements. This information is subject to change without prior notice and for reference only. It should not be used as a basis for a product guarantee or warranty. For additional information, please consult your nearest CONRAD Sales Office or Distributor or visit our website