

THIS DOCUMENT IS THE PROPERTY OF KEYSTONE ELECTRONICS CORP. AND SHALL NOT BE REPRODUCED, DISTRIBUTED OR USED AS A BASIS FOR MANUFACTURE WITHOUT PRIOR WRITTEN PERMISSION FROM KEYSTONE ELECTRONICS CORP.

ACTUAL SIZE

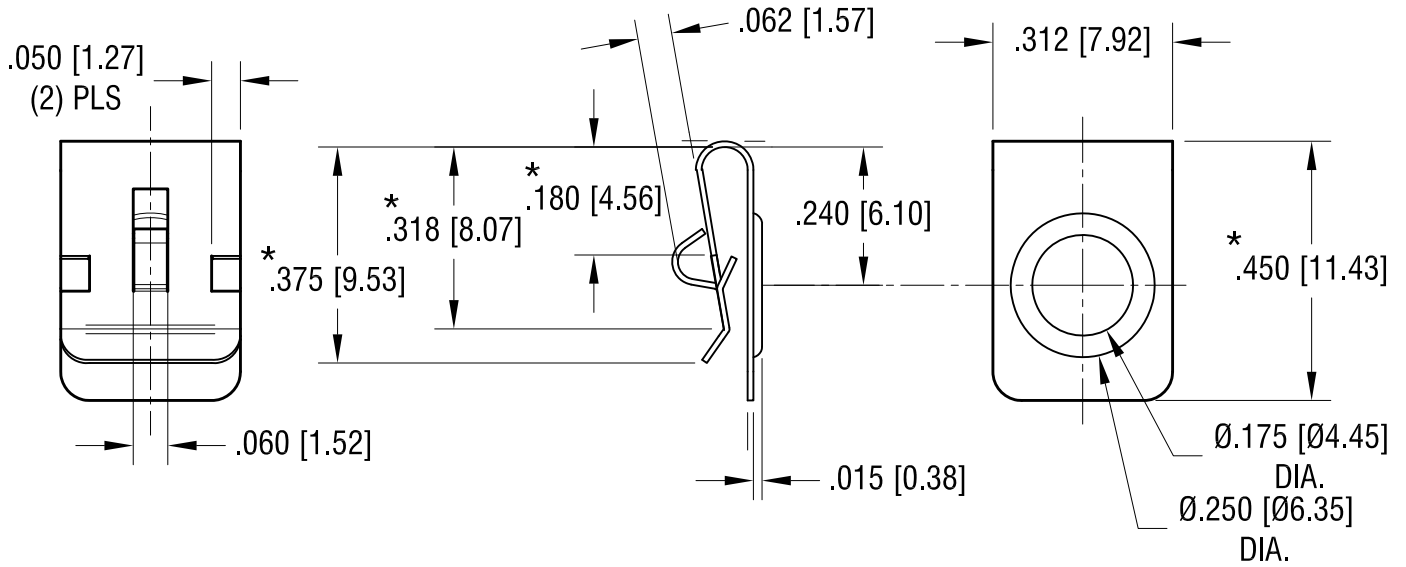
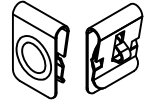

NOTE:

1. HEAT TREAT TO SPRING TEMPER.
2. DESIGNED TO CLIP OVER PANEL FROM .060 [1.52] THRU .070 [1.78] TH'K
3. * DENOTES $\pm .015$ [± 0.38] TOLERANCE

3.19.13	CHANGE AS PER ECN 13-028	H
8.14.12	ECN 12-104, CHANGE LOOP	G
3.23.07	CHANGE AS PER ECN 07-015	F
DATE	DESCRIPTION	REV.

PART NAME				SINGLE 'A'-AA CONTACT			
MATERIAL				.010 [0.25] TH'K ANNEALED SPRING STEEL			
FINISH				DRN BY		DATE	
NICKEL PLATE				BOONE		2.3.98	
				APP'D		SCALE	
				LN		3X	
TOLERANCES			INCH	[MM]	CODE		
DECIMAL			$\pm .010$	[± 0.25]	DWG NO.		
ANGULAR			$\pm 1^\circ$	UNLESS OTHERWISE SPECIFIED			
			C		228		