

THIS DOCUMENT IS THE PROPERTY OF KEYSTONE ELECTRONICS CORP. AND SHALL NOT BE REPRODUCED, DISTRIBUTED OR USED AS A BASIS FOR MANUFACTURE WITHOUT PRIOR WRITTEN PERMISSION FROM KEYSTONE ELECTRONICS CORP.

REQUIRED SPACING FOR 'AA' CLIP

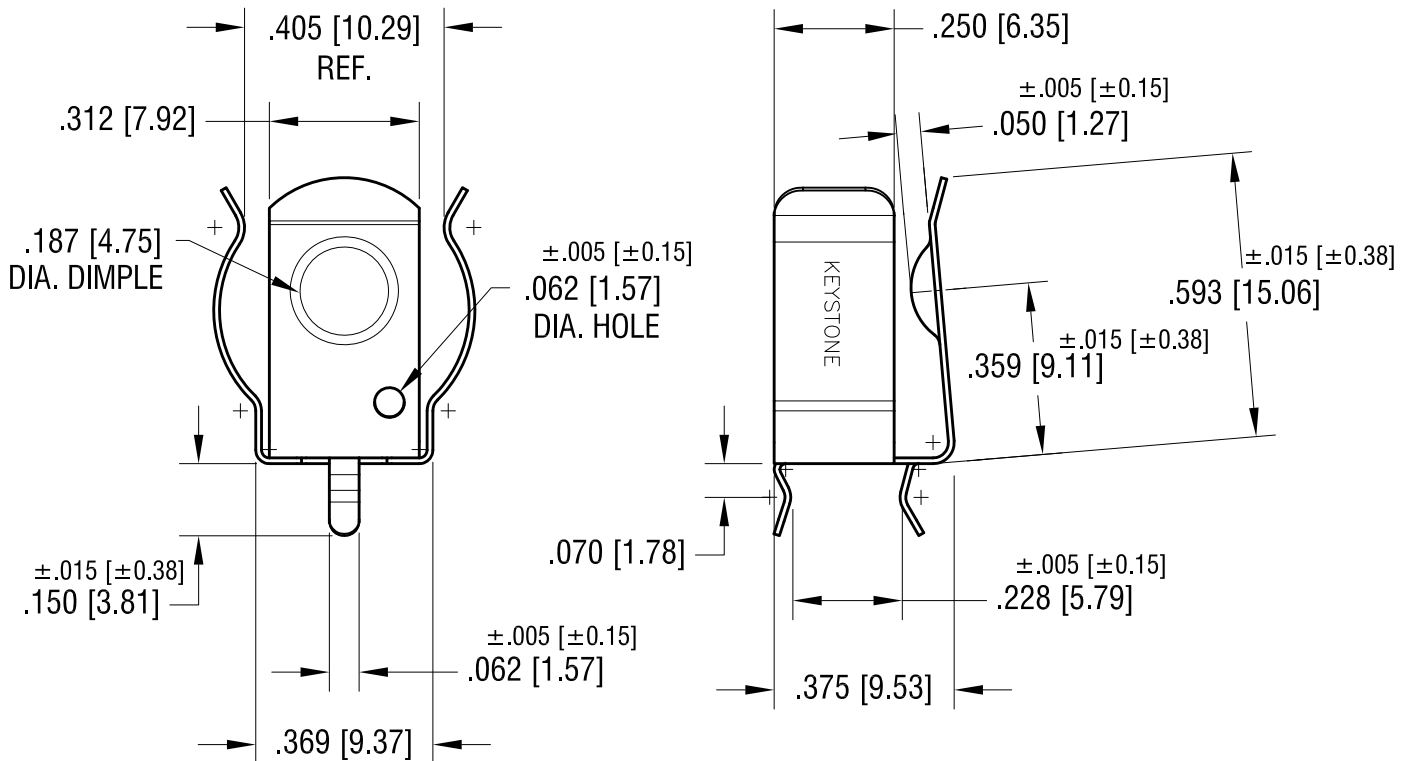
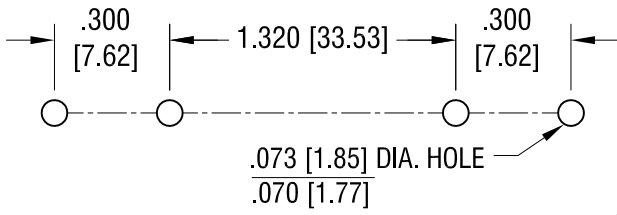

NOTE:

1. HEAT TREAT TO SPRING TEMPER.

9.06.16	CHANGE AS PER ECR 16-065	N
9.01.16	CHANGE AS PER ECN16-083	M
7.11.14	CHANGE AS PER ECN14-065	L
6.19.06	CHANGE AS PER ECN 06-038	K
DATE	DESCRIPTION	REV.

PART NAME				'A' & 'AA' PC BATTERY CLIP			
MATERIAL				.012 [.30] TH'K ANNEALED SPRING STEEL			
FINISH				DRN BY		DATE	
TIN NICKEL PLATE				BOONE		4.26.89	
				APP'D		SCALE	
				LN		2.5X	
TOLERANCES				INCH		[MM]	
DECIMAL				± .010		[± 0.25 ]	
ANGULAR				± 2°		UNLESS OTHERWISE SPECIFIED	
CODE				C			
DWG NO.				92			