

DATE	DESCRIPTION	REV.
3.11.03	CHANGE AS PER ECN 03-022	A
6.24.10	CHANGE AS PER ECN 10-046	B

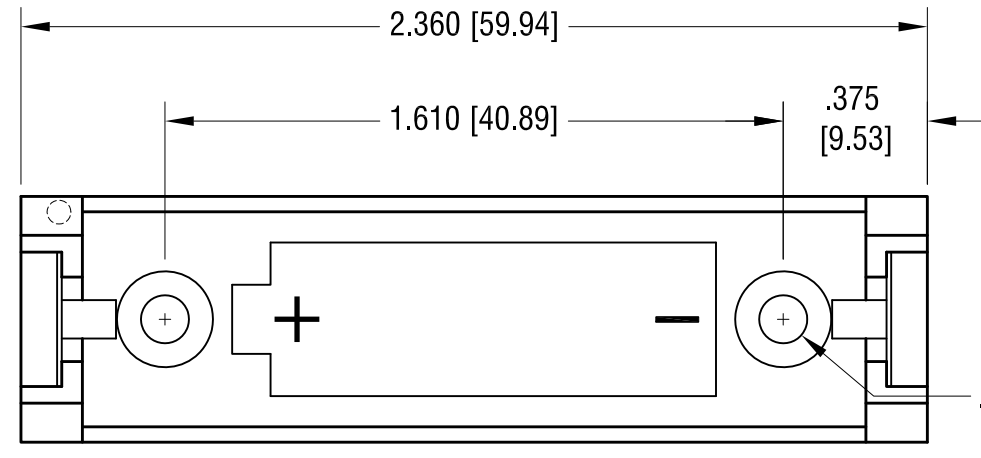

$\pm .005$ [± 0.15]
.125 [3.18] DIA.
HOLE (2) PLS

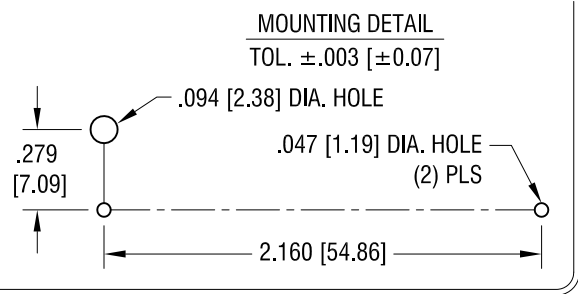
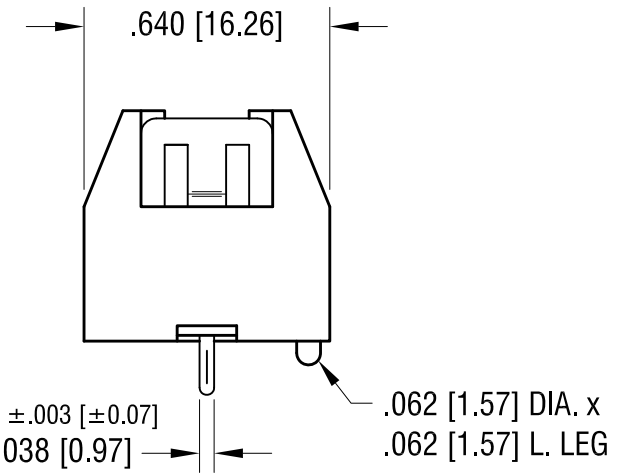
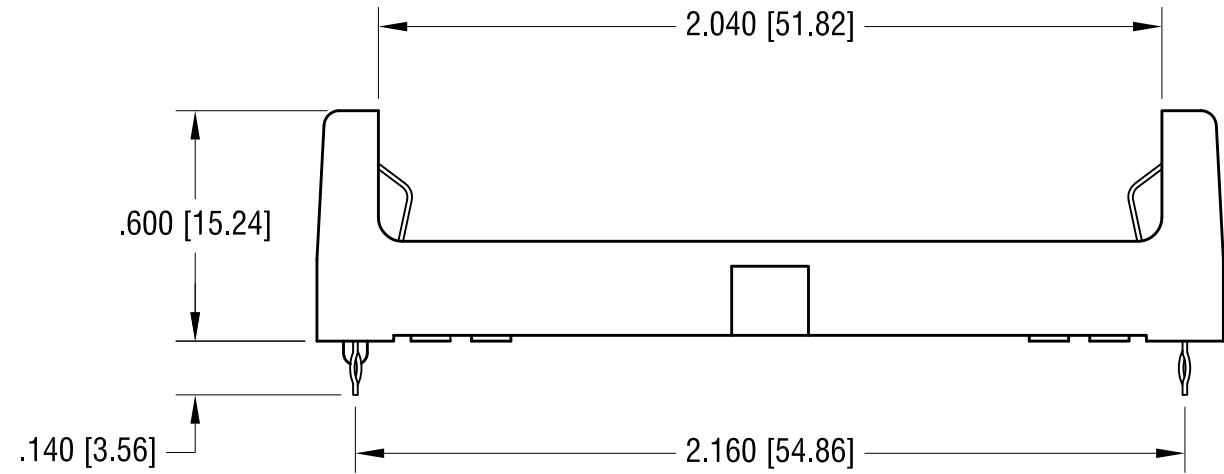

NOTE:
1. BASE:
MAT'L: PBT, BLACK UL 94V-0.
2. CONTACT:
MAT'L: .012 [0.30] THK STAINLESS STEEL.
FINISH: TIN NICKEL PLATE.

THIS DOCUMENT IS THE PROPERTY OF KEYSTONE ELECTRONICS CORP. AND SHALL NOT BE REPRODUCED, DISTRIBUTED OR USED AS A BASIS FOR MANUFACTURE WITHOUT PRIOR WRITTEN PERMISSION FROM KEYSTONE ELECTRONICS CORP.

PART NAME				PC BATTERY HOLDER, AA	
MATERIAL				AS NOTED	
FINISH		DRN BY	BOONE	DATE	9.30.96
AS NOTED		APPD	LN	SCALE	2X
TOLERANCES	INCH	[MM]	CODE	DWG NO.	
DECIMAL	$\pm .010$	[± 0.25]	C	1028	
ANGULAR	$\pm 1^\circ$				
UNLESS OTHERWISE SPECIFIED					