

Selection diagram

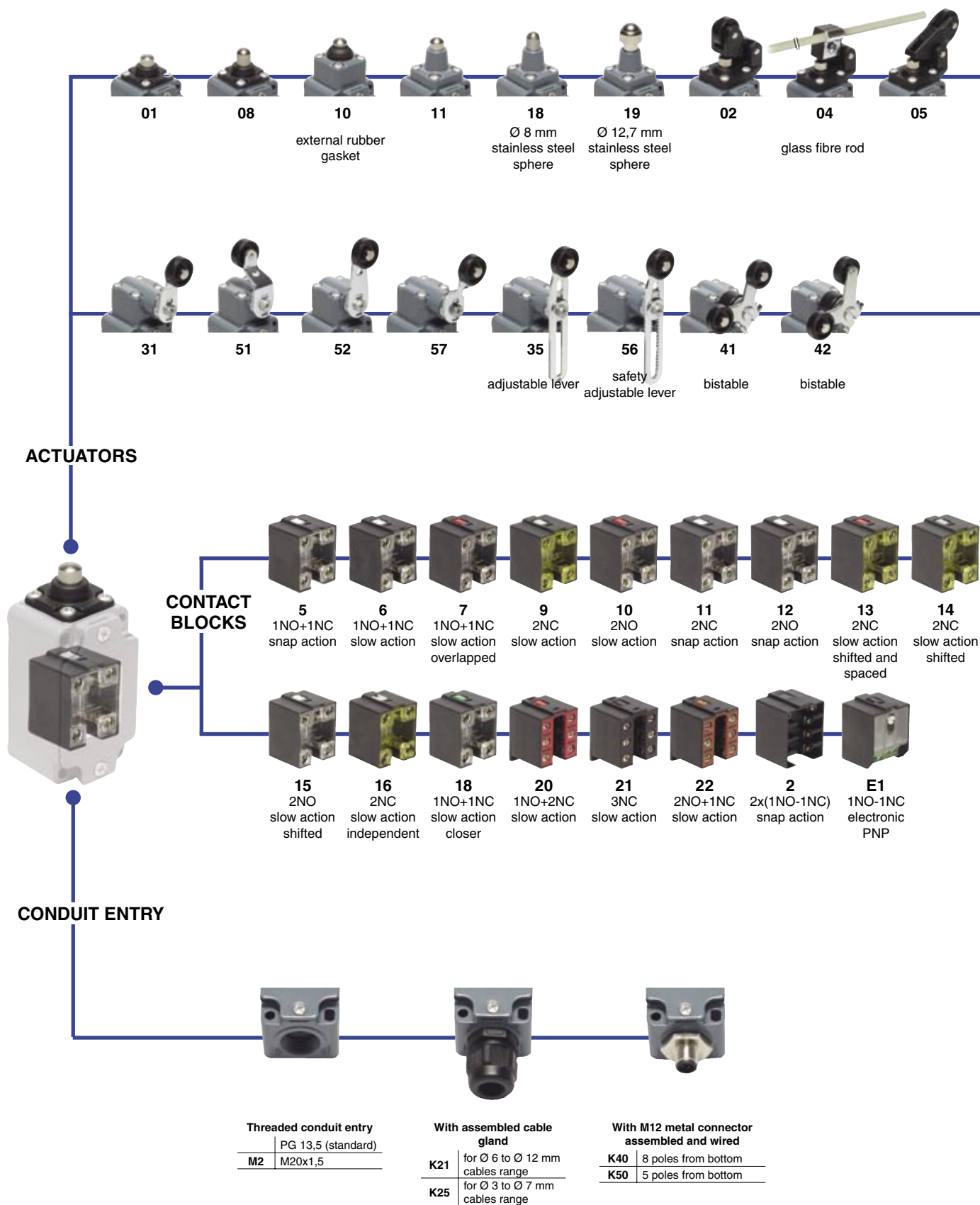

● product option
 → accessory sold separately

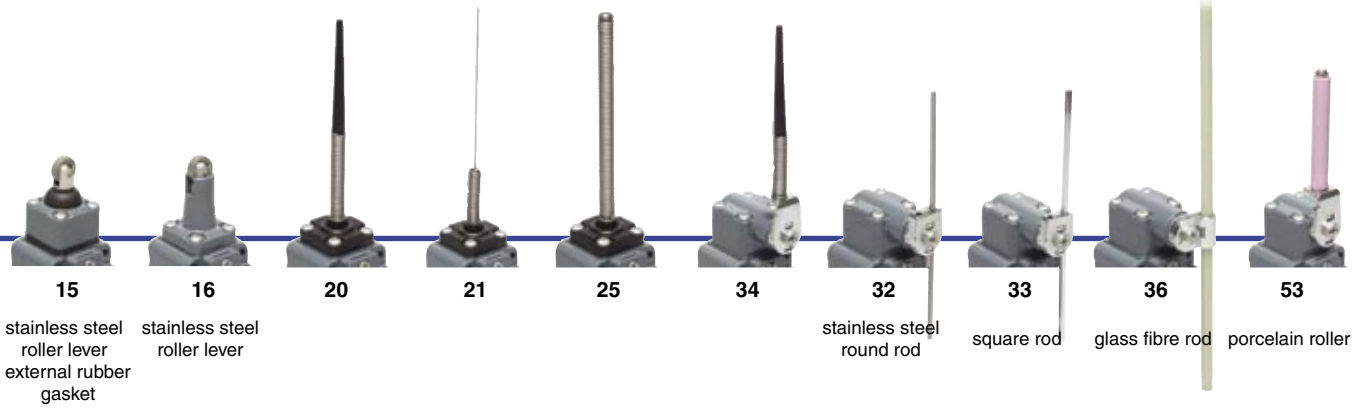

Code structure

Attention! The feasibility of a code number does not mean the effective availability of a product. Please contact our sales office.

FD 502-1GM2K50

Housing		Preinstalled cable gland or connectors	
FD	metal housing, one conduit entry		no cable gland or connector (standard)
Contact blocks		K21	with assembled cable gland suitable for Ø 6 to Ø 12 mm cables range
5	1NO+1NC, snap action	K40	with M12 metal connector assembled and wired, 8 poles (only for contact blocks 2, 20, 21, 22)
6	1NO+1NC, slow action
7	1NO+1NC, slow action overlapped	For the complete list of all combinations, please contact our technical office.	
...	Threaded conduit entry	
Actuators			PG 13,5 (standard)
01	short plunger	M2	M20x1,5
02	roller lever	Contacts type	
05	offset roller lever		silver contacts (standard)
...	G	silver contacts gold plated 1 µm (contact block 2 excluded)
Suffix			
	no suffix (standard)		
1	with Ø 20 mm stainless steel roller for actuators 02, 05, 31, 35, 51, 52, 56, 57, 41, 42		
2	with Ø 35 mm polymer roller (see special loose actuators on page 2/12)		
3	with Ø 50 mm rubber roller (see special loose actuators on page 2/12)		
4	with Ø 50 mm overhanging rubber roller (see special loose actuators on page 2/12)		



Main data

- Metal housing, one conduit entry
- Protection degree IP67
- 17 contact blocks available
- 28 actuators available
- M12 assembled connector versions
- Silver contacts gold plated versions

Markings and quality marks:

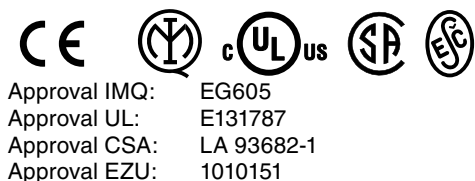

Technical data

Housing

Metal housing, coated with baked epoxy powder
 One threaded conduit entry
 Protection degree: IP67

General data

Ambient temperature: from -25°C to +80°C
 Version for operation in ambient temperature from -40°C to +80°C on request
 Max operating frequency: 3600 operations cycles/hour
 Mechanical endurance: 20 million operations cycles¹
 Assembling position: any
(1) One operation cycle means two movements, one to close and one to open contacts, as foreseen by IEC 947-5-1 standard.

Cross section of the conductors (flexible copper wire)

Contact blocks 20, 21, 22, 33, 34:	min.	1 x 0,34 mm ²	(1 x AWG 22)
	max.	2 x 1,5 mm ²	(2 x AWG 16)
Contact blocks 5, 6, 7, 9, 10, 11, 12, 13, 14, 15, 16, 18:	min.	1 x 0,5 mm ²	(1 x AWG 20)
	max.	2 x 2,5 mm ²	(2 x AWG 14)
Contact block 2:	min.	1 x 0,5 mm ²	(1 x AWG 20)
	max.	2 x 1,5 mm ²	(2 x AWG 16)

In conformity with standards:

IEC 947-5-1, IEC 337-1, EN 60947-5-1, CEI EN 60947-5-1, CEI 17-45, EN 50041, CEI 17-31, IEC 204-1, EN 60204-1, EN 44-5, EN 1088, EN ISO 12100-1, EN ISO 12100-2, IEC 529, EN 60529, CEI 70-1, NFC 63-140, VDE 0660-200, VDE 0113, CENELEC EN 50013.

Approvals:

IEC 947-5-1, UL 508, CSA C22-2 nr.14.

In conformity with requirements requested by:

Low Voltage Directive 73/23/EEC and subsequent modifications and completions.
 Machinery Directive 98/37/EEC.
 Electromagnetic Compatibility 89/336/EEC and subsequent modifications and completions.

Positive contact opening in conformity with standards:

IEC 947-5-1, EN 60947-5-1, CEI EN 60947-5-1, VDE 0660-206.

Installation for safety applications:

Use only switches marked with the symbol . The safety circuit must always be connected with the **NC contacts** (normally closed contacts: 11-12, 21-22 or 31-32) as stated in the **standard CEI EN 60947-5-1, encl. K, par. 2**. The switch must be actuated with **at least up to the positive opening travel** shown in the travels diagrams on page 6/14. The switch must be actuated **at least with the positive opening force**, shown in brackets, underneath each article, near the value of the min. force.

For the correct installation of all articles, please see "Utilization requirements" chapter, from page 6/1 to page 6/4.

Electrical data

Utilization categories

without connector	with 5 poles M12 connector	with 8 poles M12 connector
Thermal current (I _{th}):	4 A	2 A
Rated insulation voltage (U _i):	250 VAC 300 VDC	30 VAC 36 VDC
Protection against short circuits:	fuse 4 A 500 V type gG	fuse 2 A 500 V type gG
Pollution degree:	3	3
Alternate current: AC15 (50...60 Hz)	U _e (V) 24 120 250	U _e (V) 24
	I _e (A) 4 4 4	I _e (A) 2
Direct current: DC13	U _e (V) 24 125 250	U _e (V) 24
	I _e (A) 6 1,1 0,4	I _e (A) 2

Data type approved by IMQ and EZU

Rated insulation voltage (Ui): 500 VAC
 400 VAC for contact blocks 20, 21, 22, 33, 34

Thermal current (Ith): 10 A

Protection against short circuits: fuse 10 A 500 V type aM

Protection degree: IP67

MV terminals (screw clamps)

Pollution degree 3

Utilization category: AC15

Operation voltage (Ue): 400 VAC (50 Hz)

Operation current (Ie): 3 A

Forms of the contact element: Za, Zb, Za+Za, Y+Y, X+X, Y+Y+X, Y+Y+Y, Y+X+X

Positive opening of contacts on contact block 5, 6, 7, 9, 11, 12, 13, 14, 16, 18, 20, 21, 22, 33, 34

In conformity with standards: EN60947-1, EN 60947-5-1 and subsequent modifications and completions, fundamental requirements of the Low Voltage Directive 73/23 EEC and subsequent modifications and completions.

Please contact our technical service for the list of type approved products.

Data type approved by UL

Utilization categories Q300 (69 VA, 125-250 VDC)
 A600 (720 VA, 120-600 VAC)

Data of the housing type 1, 4X (indoor use only), 12, 13

In conformity with standard: UL 508

For all contact blocks except 2 and 3 use 60 or 75 °C copper (Cu) conductor and wire size No. 12-14 AWG. Terminal tightening torque of 7,1 Lb-In.

For contact blocks 2 and 3 use 60 or 75 °C copper (Cu) conductor and wire size No. 14 AWG. Terminal tightening torque of 12 Lb-In.

Please contact our technical service for the list of type approved products.

Data type approved by CSA

Utilization categories Q300 (69 VA, 125-250 VDC)
 A600 (720 VA, 120-600 VAC)

Data of the housing type 1, 4X (indoor use only), 12, 13

In conformity with standard: CSA C22-2 nr.14

Please contact our technical service for the list of type approved products.

Adjustable levers

In switches with revolving lever it is possible to adjust the lever with 10° steps for the whole 360° range. The positive movement transmission is always guaranteed thanks to the particular geometrical coupling between the lever and the revolving shaft as prescribed for safety applications by the German standard BG-GS-ET-15.

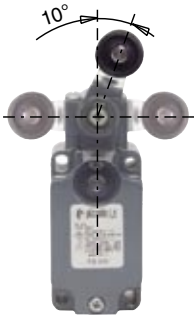

Overturning levers

It's possible to fasten the lever on switches on straight or reverse side, maintaining the positive coupling. In this way it is possible to obtain two different work plans of the lever.





Rotating heads

In all switches, it is possible to rotate the head in 90° steps.



Working operation of contact block 16 with independent contacts

The contact block 16 has two NC contacts, both with positive opening activated independently according to the lever turning direction.

<p>Lever turned to left</p>  <p>Contacts diagram</p> <pre> 11 / 12 21 \ 22 </pre>	<p>Lever not turned</p>  <p>Contacts diagram</p> <pre> 11 / 12 21 / 22 </pre>	<p>Lever turned to right</p>  <p>Contacts diagram</p> <pre> 11 \ 12 21 / 22 </pre>
--	---	---

Unidirectional heads

In the switches with revolving lever, it is possible to select the directional operation by removing the four screws of the head and revolving the internal piston (contact block 16 excluded).

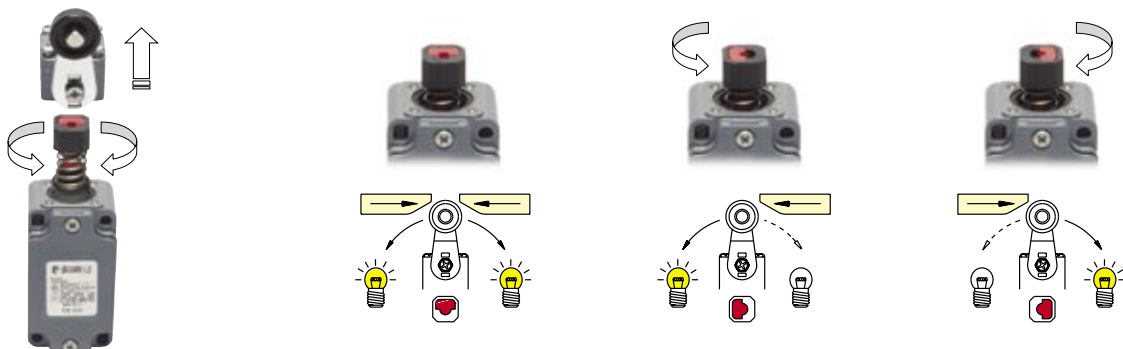

2 Position switches FD series

Contacts type:

- R** = snap action
- L** = slow action
- LO** = slow action overlapped
- LS** = slow action shifted
- LV** = slow action shifted and spaced
- LI** = slow action independent
- LA** = slow action closer
- E1** = electronic PNP

Contact blocks

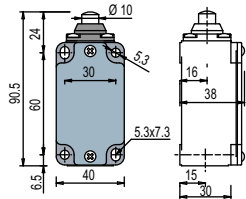

With stainless steel roller on request

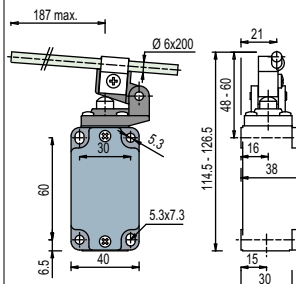
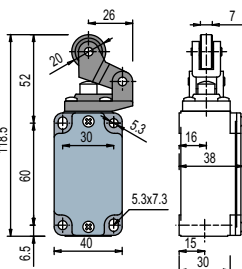

With stainless steel roller on request

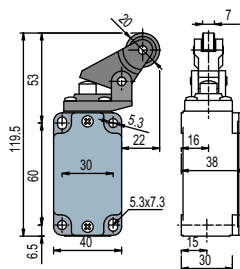

5	R	FD 501	1NO+1NC	FD 502	1NO+1NC	FD 504	1NO+1NC	FD 505	1NO+1NC
6	L	FD 601	1NO+1NC	FD 602	1NO+1NC	FD 604	1NO+1NC	FD 605	1NO+1NC
7	LO	FD 701	1NO+1NC	FD 702	1NO+1NC	FD 704	1NO+1NC	FD 705	1NO+1NC
9	L	FD 901	2NC	FD 902	2NC	FD 904	2NC	FD 905	2NC
10	L	FD 1001	2NO	FD 1002	2NO	FD 1004	2NO	FD 1005	2NO
11	R	FD 1101	2NC	FD 1102	2NC	FD 1104	2NC	FD 1105	2NC
12	R	FD 1201	2NO	FD 1202	2NO	FD 1204	2NO	FD 1205	2NO
13	LV	FD 1301	2NC	FD 1302	2NC	FD 1304	2NC	FD 1305	2NC
14	LS	FD 1401	2NC	FD 1402	2NC	FD 1404	2NC	FD 1405	2NC
15	LS	FD 1501	2NO	FD 1502	2NO	FD 1504	2NO	FD 1505	2NO
18	LA	FD 1801	1NO+1NC	FD 1802	1NO+1NC	FD 1804	1NO+1NC	FD 1805	1NO+1NC
20	L	FD 2001	1NO+2NC	FD 2002	1NO+2NC	FD 2004	1NO+2NC	FD 2005	1NO+2NC
21	L	FD 2101	3NC	FD 2102	3NC	FD 2104	3NC	FD 2105	3NC
22	L	FD 2201	2NO+1NC	FD 2202	2NO+1NC	FD 2204	2NO+1NC	FD 2205	2NO+1NC
2	R	FD 201	2x(1NO-1NC)	FD 202	2x(1NO-1NC)	FD 204	2x(1NO-1NC)	FD 205	2x(1NO-1NC)
E1	E1	FD E101	1NO-1NC	FD E102	1NO-1NC	FD E104	1NO-1NC	FD E105	1NO-1NC
Max speed		page 6/2 - type 4		page 6/2 - type 3		0,5 m/s		page 6/2 - type 3	
Min. force		8 N (25 N ⊕)		6 N (25 N ⊕)		0,17 Nm		6 N (25 N ⊕)	
Travel diagrams		page 6/14 - group 1		page 6/14 - group 2		page 6/14 - group 1		page 6/14 - group 2	

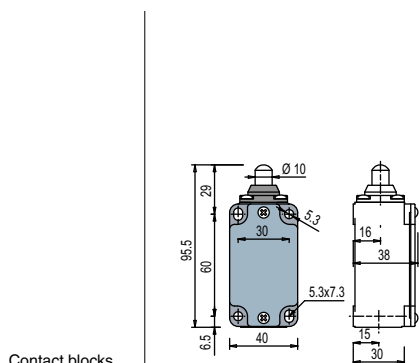

With external rubber gasket

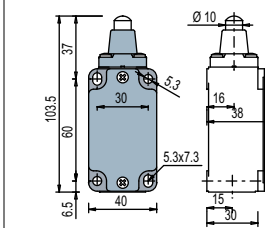
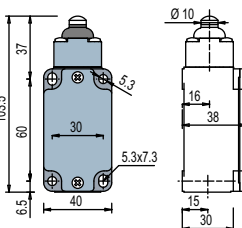

With external rubber gasket

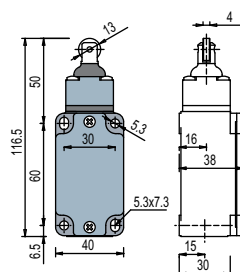

Contact blocks

5	R	FD 508	1NO+1NC	FD 510	1NO+1NC	FD 511	1NO+1NC	FD 515	1NO+1NC
6	L	FD 608	1NO+1NC	FD 610	1NO+1NC	FD 611	1NO+1NC	FD 615	1NO+1NC
7	LO	FD 708	1NO+1NC	FD 710	1NO+1NC	FD 711	1NO+1NC	FD 715	1NO+1NC
9	L	FD 908	2NC	FD 910	2NC	FD 911	2NC	FD 915	2NC
10	L	FD 1008	2NO	FD 1010	2NO	FD 1011	2NO	FD 1015	2NO
11	R	FD 1108	2NC	FD 1110	2NC	FD 1111	2NC	FD 1115	2NC
12	R	FD 1208	2NO	FD 1210	2NO	FD 1211	2NO	FD 1215	2NO
13	LV	FD 1308	2NC	FD 1310	2NC	FD 1311	2NC	FD 1315	2NC
14	LS	FD 1408	2NC	FD 1410	2NC	FD 1411	2NC	FD 1415	2NC
15	LS	FD 1508	2NO	FD 1510	2NO	FD 1511	2NO	FD 1515	2NO
18	LA	FD 1808	1NO+1NC	FD 1810	1NO+1NC	FD 1811	1NO+1NC	FD 1815	1NO+1NC
20	L	FD 2008	1NO+2NC	FD 2010	1NO+2NC	FD 2011	1NO+2NC	FD 2015	1NO+2NC
21	L	FD 2108	3NC	FD 2110	3NC	FD 2111	3NC	FD 2115	3NC
22	L	FD 2208	2NO+1NC	FD 2210	2NO+1NC	FD 2211	2NO+1NC	FD 2215	2NO+1NC
2	R	FD 208	2x(1NO-1NC)	FD 210	2x(1NO-1NC)	FD 211	2x(1NO-1NC)	FD 215	2x(1NO-1NC)
E1	E1	FD E108	1NO-1NC	FD E110	1NO-1NC	FD E111	1NO-1NC	FD E115	1NO-1NC
Max speed		page 6/2 - type 4		page 6/2 - type 4		page 6/2 - type 4		page 6/2 - type 2	
Min. force		8 N (25 N ⊕)		11 N (25 N ⊕)		8 N (25 N ⊕)		11 N (25 N ⊕)	
Travel diagrams		page 6/14 - group 1		page 6/14 - group 1		page 6/14 - group 1		page 6/14 - group 1	

Accessories
See page 5/1

Items with code on the green background are available in stock

All measures in the drawings are in mm

- Contacts type:
- R** = snap action
 - L** = slow action
 - LO** = slow action overlapped
 - LS** = slow action shifted
 - LV** = slow action shifted and spaced
 - LI** = slow action independent
 - LA** = slow action closer
 - E** = electronic PNP

Contact blocks

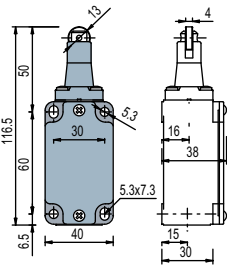

Ø 8 mm stainless steel sphere

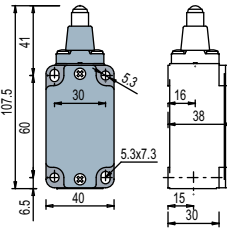

Ø 12,7 mm stainless steel sphere

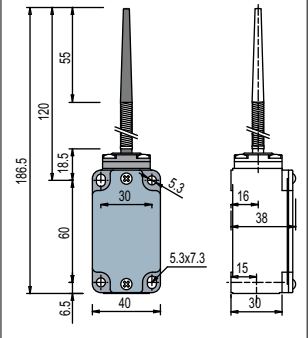
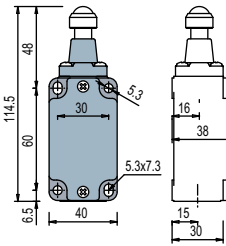

5	R	FD 516	⊕ 1NO+1NC	FD 518	⊕ 1NO+1NC	FD 519	⊕ 1NO+1NC	FD 520	1NO+1NC
6	L	FD 616	⊕ 1NO+1NC	FD 618	⊕ 1NO+1NC	FD 619	⊕ 1NO+1NC		
7	LO	FD 716	⊕ 1NO+1NC	FD 718	⊕ 1NO+1NC	FD 719	⊕ 1NO+1NC		
9	L	FD 916	⊕ 2NC	FD 918	⊕ 2NC	FD 919	⊕ 2NC		
10	L	FD 1016	2NO	FD 1018	2NO	FD 1019	2NO	FD 1020	2NO
11	R	FD 1116	⊕ 2NC	FD 1118	⊕ 2NC	FD 1119	⊕ 2NC		
12	R	FD 1216	2NO	FD 1218	2NO	FD 1219	2NO	FD 1220	2NO
13	LV	FD 1316	⊕ 2NC	FD 1318	⊕ 2NC	FD 1319	⊕ 2NC		
14	LS	FD 1416	⊕ 2NC	FD 1418	⊕ 2NC	FD 1419	⊕ 2NC		
15	LS	FD 1516	2NO	FD 1518	2NO	FD 1519	2NO		
18	LA	FD 1816	⊕ 1NO+1NC	FD 1818	⊕ 1NO+1NC	FD 1819	⊕ 1NO+1NC	FD 1820	1NO+1NC
20	L	FD 2016	⊕ 1NO+2NC	FD 2018	⊕ 1NO+2NC	FD 2019	⊕ 1NO+2NC	FD 2020	1NO+2NC
21	L	FD 2116	⊕ 3NC	FD 2118	⊕ 3NC	FD 2119	⊕ 3NC	FD 2120	3NC
22	L	FD 2216	⊕ 2NO+1NC	FD 2218	⊕ 2NO+1NC	FD 2219	⊕ 2NO+1NC	FD 2220	2NO+1NC
2	R	FD 216	2x(1NO-1NC)	FD 218	2x(1NO-1NC)	FD 219	2x(1NO-1NC)	FD 220	2x(1NO-1NC)
E1	E	FD E116	1NO-1NC	FD E118	1NO-1NC	FD E119	1NO-1NC	FD E120	1NO-1NC
Max speed		page 6/2 - type 2		page 6/2 - type 4		page 6/2 - type 4		1 m/s	
Min. force		8 N (25 N ⊕)		8 N (25 N ⊕)		8 N (25 N ⊕)		0,09 Nm	
Travel diagrams		page 6/14 - group 1		page 6/14 - group 1		page 6/14 - group 1		page 6/14 - group 3	

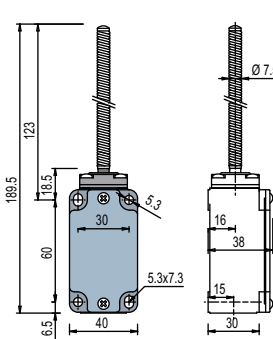
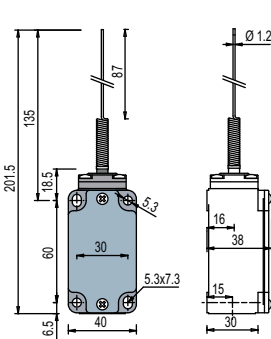

Other rollers available. See page 2/12

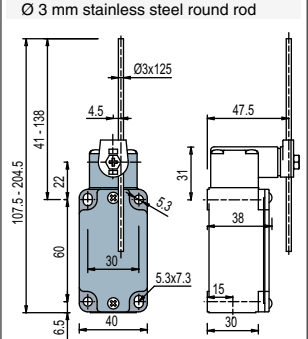
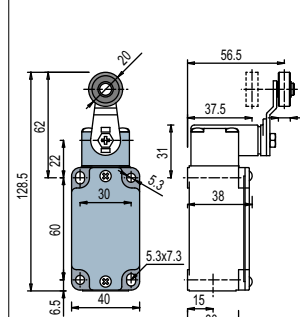

Contact blocks

5	R	FD 521	1NO+1NC	FD 525	1NO+1NC	FD 531	⊕ 1NO+1NC	FD 532	1NO+1NC
6	L					FD 631	⊕ 1NO+1NC	FD 632	1NO+1NC
7	LO					FD 731	⊕ 1NO+1NC	FD 732	1NO+1NC
9	L					FD 931	⊕ 2NC	FD 932	2NC
10	L	FD 1021	2NO	FD 1025	2NO	FD 1031	2NO	FD 1032	2NO
11	R					FD 1131	⊕ 2NC	FD 1132	2NC
12	R	FD 1221	2NO	FD 1225	2NO	FD 1231	2NO	FD 1232	2NO
13	LV					FD 1331	⊕ 2NC	FD 1332	2NC
14	LS					FD 1431	⊕ 2NC	FD 1432	2NC
15	LS					FD 1531	2NO	FD 1532	2NO
16	LI					FD 1631	⊕ 2NC	FD 1632	2NC
18	LA	FD 1821	1NO+1NC	FD 1825	1NO+1NC	FD 1831	⊕ 1NO+1NC	FD 1832	1NO+1NC
20	L	FD 2021	1NO+2NC	FD 2025	1NO+2NC	FD 2031	⊕ 1NO+2NC	FD 2032	1NO+2NC
21	L	FD 2121	3NC	FD 2125	3NC	FD 2131	⊕ 3NC	FD 2132	3NC
22	L	FD 2221	2NO+1NC	FD 2225	2NO+1NC	FD 2231	⊕ 2NO+1NC	FD 2232	2NO+1NC
2	R	FD 221	2x(1NO-1NC)	FD 225	2x(1NO-1NC)	FD 231	2x(1NO-1NC)	FD 232	2x(1NO-1NC)
E1	E	FD E121	1NO-1NC	FD E125	1NO-1NC	FD E131	1NO-1NC	FD E132	1NO-1NC
Max speed		1 m/s		1 m/s		page 6/2 - type 1		1,5 m/s	
Min. force		0,08 Nm		0,14 Nm		0,15 Nm (0,25 Nm ⊕)		0,15 Nm	
Travel diagrams		page 6/14 - group 3		page 6/14 - group 3		page 6/14 - group 4		page 6/14 - group 4	

Accessories
See page 5/1

Items with code on the green background are available in stock

- Contacts type:
- R** = snap action
 - L** = slow action
 - LO** = slow action overlapped
 - LS** = slow action shifted
 - LV** = slow action shifted and spaced
 - LI** = slow action independent
 - LA** = slow action closer
 - A** = electronic PNP

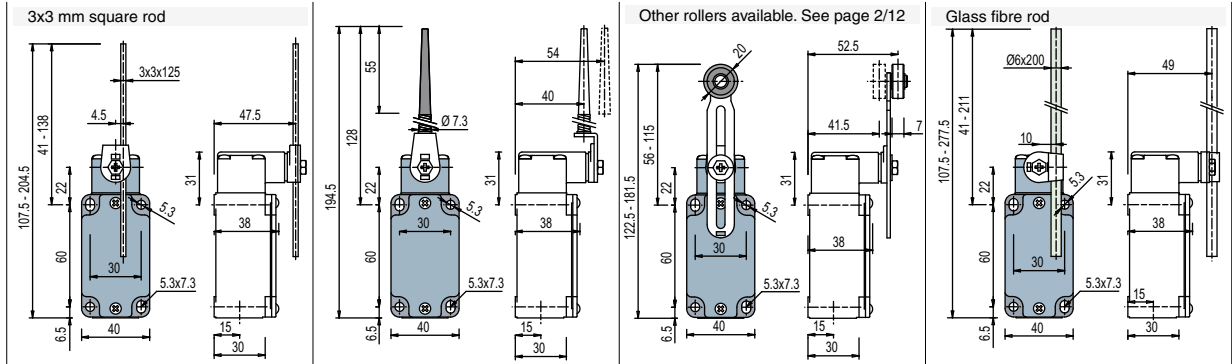

5	R	FD 533	1NO+1NC	FD 534	1NO+1NC	FD 535	(1) 1NO+1NC	FD 536	1NO+1NC
6	L	FD 633	1NO+1NC	FD 634	1NO+1NC	FD 635	(1) 1NO+1NC	FD 636	1NO+1NC
7	LO	FD 733	1NO+1NC	FD 734	1NO+1NC	FD 735	(1) 1NO+1NC	FD 736	1NO+1NC
9	L	FD 933	2NC	FD 934	2NC	FD 935	(1) 2NC	FD 936	2NC
10	L	FD 1033	2NO	FD 1034	2NO	FD 1035	2NO	FD 1036	2NO
11	R	FD 1133	2NC	FD 1134	2NC	FD 1135	(1) 2NC	FD 1136	2NC
12	R	FD 1233	2NO	FD 1234	2NO	FD 1235	2NO	FD 1236	2NO
13	LV	FD 1333	2NC	FD 1334	2NC	FD 1335	(1) 2NC	FD 1336	2NC
14	LS	FD 1433	2NC	FD 1434	2NC	FD 1435	(1) 2NC	FD 1436	2NC
15	LS	FD 1533	2NO	FD 1534	2NO	FD 1535	2NO	FD 1536	2NO
16	LI	FD 1633	2NC	FD 1634	2NC	FD 1635	(1) 2NC	FD 1636	2NC
18	LA	FD 1833	1NO+1NC	FD 1834	1NO+1NC	FD 1835	(1) 1NO+1NC	FD 1836	1NO+1NC
20	L	FD 2033	1NO+2NC	FD 2034	1NO+2NC	FD 2035	(1) 1NO+2NC	FD 2036	1NO+2NC
21	L	FD 2133	3NC	FD 2134	3NC	FD 2135	(1) 3NC	FD 2136	3NC
22	L	FD 2233	2NO+1NC	FD 2234	2NO+1NC	FD 2235	(1) 2NO+1NC	FD 2236	2NO+1NC
2	R	FD 233	2x(1NO-1NC)	FD 234	2x(1NO-1NC)	FD 235	2x(1NO-1NC)	FD 236	2x(1NO-1NC)
E1	A	FD E133	1NO-1NC	FD E134	1NO-1NC	FD E135	1NO-1NC	FD E136	1NO-1NC
Max speed	1,5 m/s		1 m/s		page 6/2 - type 1		1,5 m/s		
Min. force	0,15 Nm		0,15 Nm		0,15 Nm (0,25 Nm (1))		0,15 Nm		
Travel diagrams	page 6/14 - group 4		page 6/14 - group 4		page 6/14 - group 4		page 6/14 - group 4		

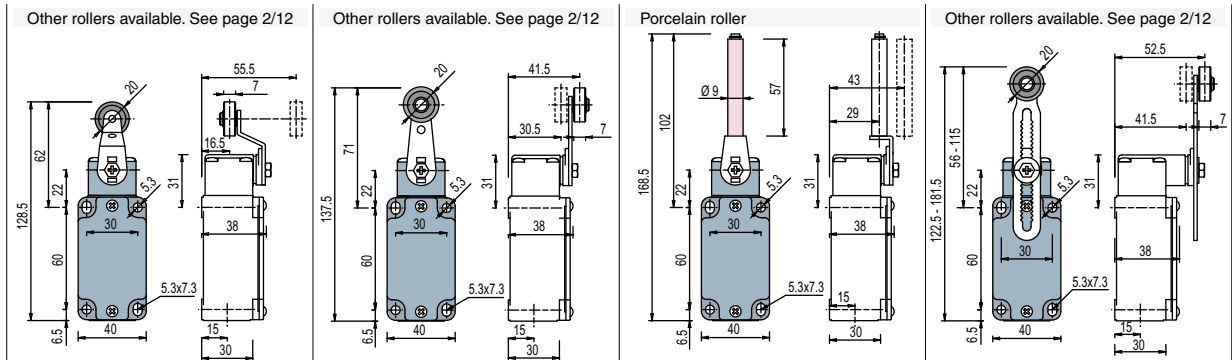

5	R	FD 551	(1) 1NO+1NC	FD 552	(1) 1NO+1NC	FD 553-E11V9	(1) 1NO+1NC	FD 556	(1) 1NO+1NC
6	L	FD 651	(1) 1NO+1NC	FD 652	(1) 1NO+1NC	FD 653-E11V9	(1) 1NO+1NC	FD 656	(1) 1NO+1NC
7	LO	FD 751	(1) 1NO+1NC	FD 752	(1) 1NO+1NC	FD 753-E11V9	(1) 1NO+1NC	FD 756	(1) 1NO+1NC
9	L	FD 951	(1) 2NC	FD 952	(1) 2NC	FD 953-E11V9	(1) 2NC	FD 956	(1) 2NC
10	L	FD 1051	2NO	FD 1052	2NO	FD 1053-E11V9	2NO	FD 1056	2NO
11	R	FD 1151	(1) 2NC	FD 1152	(1) 2NC	FD 1153-E11V9	2NO	FD 1156	(1) 2NC
12	R	FD 1251	2NO	FD 1252	2NO	FD 1253-E11V9	2NO	FD 1256	2NO
13	LV	FD 1351	(1) 2NC	FD 1352	(1) 2NC	FD 1353-E11V9	(1) 2NC	FD 1356	(1) 2NC
14	LS	FD 1451	(1) 2NC	FD 1452	(1) 2NC	FD 1453-E11V9	(1) 2NC	FD 1456	(1) 2NC
15	LS	FD 1551	2NO	FD 1552	2NO	FD 1553-E11V9	2NO	FD 1556	2NO
16	LI							FD 1656	(1) 2NC
18	LA	FD 1851	(1) 1NO+1NC	FD 1852	(1) 1NO+1NC	FD 1853-E11V9	(1) 1NO+1NC	FD 1856	(1) 1NO+1NC
20	L	FD 2051	(1) 1NO+2NC	FD 2052	(1) 1NO+2NC	FD 2053-E11V9	(1) 1NO+2NC	FD 2056	(1) 1NO+2NC
21	L	FD 2151	(1) 3NC	FD 2152	(1) 3NC	FD 2153-E11V9	(1) 3NC	FD 2156	(1) 3NC
22	L	FD 2251	(1) 2NO+1NC	FD 2252	(1) 2NO+1NC	FD 2253-E11V9	(1) 2NO+1NC	FD 2256	(1) 2NO+1NC
2	R	FD 251	2x(1NO-1NC)	FD 252	2x(1NO-1NC)	FD 253-E11	2x(1NO-1NC)	FD 256	2x(1NO-1NC)
E1	A	FD E151	1NO-1NC	FD E152	1NO-1NC	FD E153-E11V9	1NO-1NC	FD E156	1NO-1NC
Max speed	page 6/2 - type 1		page 6/2 - type 1		0,5 m/s		page 6/2 - type 1		
Min. force	0,09 Nm (0,25 Nm (1))		0,09 Nm (0,25 Nm (1))		0,06 Nm (0,25 Nm (1))		0,15 Nm (0,25 Nm (1))		
Travel diagrams	page 6/14 - group 4		page 6/14 - group 4		page 6/14 - group 5		page 6/14 - group 4		

Accessories
See page 5/1

Items with code on the green background are available in stock

(1) Positive opening only with lever adjusted on the max. See page 2/11

- Contacts type:
- R** = snap action
 - L** = slow action
 - LO** = slow action overlapped
 - LS** = slow action shifted
 - LV** = slow action shifted and spaced
 - LI** = slow action independent
 - LA** = slow action closer
 -  = electronic PNP

Contact blocks

5	R	FD 557	1NO+1NC
6	L	FD 657	1NO+1NC
7	LO	FD 757	1NO+1NC
9	L	FD 957	2NC
10	L	FD 1057	2NO
11	R	FD 1157	2NC
12	R	FD 1257	2NO
13	LV	FD 1357	2NC
14	LS	FD 1457	2NC
15	LS	FD 1557	2NO
16	LI	FD 1657	2NC
18	LA	FD 1857	1NO+1NC
20	L	FD 2057	1NO+2NC
21	L	FD 2157	3NC
22	L	FD 2257	2NO+1NC
2	R	FD 257	2x(1NO-1NC)
E1		FD E157	1NO-1NC

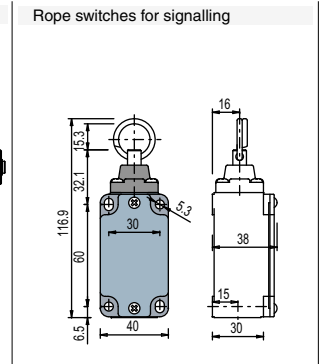
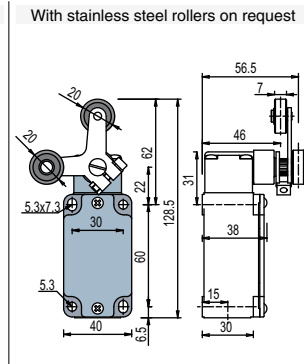
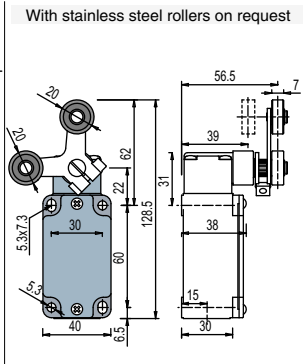
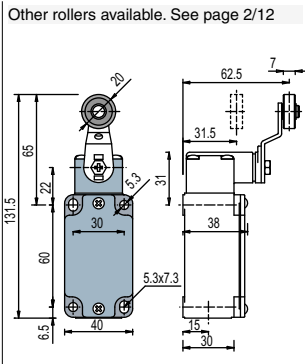

FD 541 1NO+1NC

Bistable switch with single track lyra lever

S = mechanical snap point

FD 542 1NO+1NC

Bistable switch with double tracks lyra lever

S = mechanical snap point

FD 576	1NO+1NC
FD 676	1NO+1NC
FD 776	1NO+1NC
FD 976	2NO
FD 1076	2NC
FD 1176	2NO
FD 1276	2NC
FD 1376	2NO
FD 1476	2NO
FD 1576	2NC
FD 1876	1NO+1NC
FD 2076	2NO+1NC
FD 2176	3NO
FD 2276	1NO+2NC
FD 276	2x(1NO-1NC)

Max speed	page 6/2 - type 1	0,5 m/s with 30° cam	0,5 m/s with 30° cam	0,5 m/s
Min. force	0,15 Nm (0,25 Nm ↻)	0,21 Nm	0,21 Nm	initial 20 N - final 40 N
Travel diagrams	page 6/14 - group 4			page 6/14 - group 6

Accessories
See page 5/1

Items with code on the green background are available in stock

2 Position switches FD series

Position switches with revolving lever without actuator

Contacts type:

- R** = snap action
- L** = slow action
- LO** = slow action overlapped
- LS** = slow action shifted
- LV** = slow action shifted and spaced
- LI** = slow action independent
- LA** = slow action closer
- △** = electronic PNP

Contact blocks

Regular head

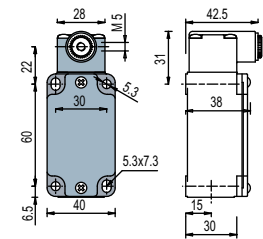

Compact head

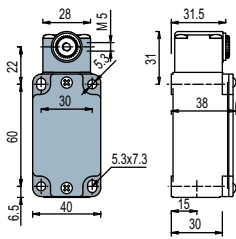

IMPORTANT

For safety applications: join only switches and actuators marked with symbol \ominus .
For more information about safety applications see page 6/1.

5	R	FD 538	\ominus 1NO+1NC	FD 558	\ominus 1NO+1NC
6	L	FD 638	\ominus 1NO+1NC	FD 658	\ominus 1NO+1NC
7	LO	FD 738	\ominus 1NO+1NC	FD 758	\ominus 1NO+1NC
9	L	FD 938	\ominus 2NC	FD 958	\ominus 2NC
10	L	FD 1038	2NO	FD 1058	2NO
11	R	FD 1138	\ominus 2NC	FD 1158	\ominus 2NC
12	R	FD 1238	2NO	FD 1258	2NO
13	LV	FD 1338	\ominus 2NC	FD 1358	\ominus 2NC
14	LS	FD 1438	\ominus 2NC	FD 1458	\ominus 2NC
15	LS	FD 1538	2NO	FD 1558	2NO
16	LI	FD 1638	\ominus 2NC		
18	LA	FD 1838	\ominus 1NO+1NC	FD 1858	\ominus 1NO+1NC
20	L	FD 2038	\ominus 1NO+2NC	FD 2058	\ominus 1NO+2NC
21	L	FD 2138	\ominus 3NC	FD 2158	\ominus 3NC
22	L	FD 2238	\ominus 2NO+1NC	FD 2258	\ominus 2NO+1NC
2	R	FD 238	2x(1NO-1NC)	FD 258	2x(1NO-1NC)
E1	△	FD E138	1NO-1NC	FD E158	1NO-1NC
Min. force		0,15 Nm (0,25 Nm \ominus)		0,09 Nm (0,25 Nm \ominus)	
Travel diagrams		page 6/14 - group 4		page 6/14 - group 4	

Items with code on the green background are available in stock

Accessories
See page 5/1

Loose actuators

IMPORTANT: These loose actuators can be used with items of series FD, FP, FL, FC only

	Polymer roller Ø 20 mm	Adjustable round rod Ø 3x125 mm	Adjustable square rod 3x3x125 mm	Flexible rod actuator	Adjustable actuator with polymer roller	Adjustable glass fibre rod
10 pcs pack						
Article	VF L31 \ominus	VF L32 ⁽³⁾	VF L33 ⁽³⁾	VF L34	VF L35 \ominus ^{(1) (3)}	VF L36 ⁽³⁾
	Polymer roller Ø 20 mm	Polymer roller Ø 20 mm	Porcelain roller	Adjustable safety actuator with polymer roller	Polymer roller Ø 20 mm	
10 pcs pack						
Article	VF L51 \ominus	VF L52 \ominus	VF L53 \ominus ⁽²⁾	VF L56 \ominus ⁽³⁾	VF L57 \ominus	

- Only orders for multiple quantities of the packs are accepted.

- ⁽¹⁾ Actuator VF L35 suits to safety applications only if adjusted to its max length, as you can see in figure beside. If you need an adjustable lever for safety applications, use the adjustable safety lever VF L56.

- ⁽²⁾ The position switch obtained by assembling the switch FD •58 (e.g. FD 558, FD 658) with the actuator VF L53 will not present the same travel diagrams and actuating forces as the position switch FD •53-E11V9 (e.g. FD 553-E11V9, FD 653-E11V9...).

- ⁽³⁾ If it is installed with switch FD •58 (e.g. FD 558, FD 658.), the actuator can mechanically interfere with the housing of the switch. The interference could happen or not according to the actuator and the head fixing position.

- ⁽⁴⁾ The actuator cannot be oriented to inside direction because it will mechanically interfere with the switch head.

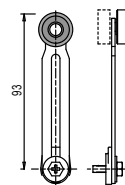

Special loose actuators

IMPORTANT: These loose actuators can be used with items of series FD, FP, FL, FC only

<p>10 pcs pack</p> <p>Ø 20 mm stainless steel rollers</p>						
						<p>Article</p> <p>VF L31-1 (1) (3)</p> <p>VF L35-1 (1) (3)</p> <p>VF L51-1 (1) (3)</p> <p>VF L52-1 (1) (3)</p> <p>VF L56-1 (1) (3)</p> <p>VF L57-1 (1) (3)</p>
<p>10 pcs pack</p> <p>Ø 35 mm polymer rollers</p>						
						<p>Article</p> <p>VF L31-2 (1) (3)</p> <p>VF L35-2 (1) (3)</p> <p>VF L51-2 (1) (3)</p> <p>VF L52-2 (1) (3)</p> <p>VF L56-2 (1) (3)</p> <p>VF L57-2 (1) (3)</p>
<p>10 pcs pack</p> <p>Ø 40 mm rubber rollers</p>						
						<p>Article</p> <p>VF L31-R5 (1) (3)</p> <p>VF L35-R5 (1) (3)</p> <p>VF L51-R5 (1) (3)</p> <p>VF L52-R5 (1) (3)</p> <p>VF L56-R5 (1) (3)</p> <p>VF L57-R5 (1) (3)</p>
<p>10 pcs pack</p> <p>Ø 50 mm rubber rollers</p>						
						<p>Article</p> <p>VF L31-3 (1) (3)</p> <p>VF L35-3 (1) (3)</p> <p>VF L51-3 (1) (3)</p> <p>VF L52-3 (1) (3)</p> <p>VF L56-3 (1) (3)</p> <p>VF L57-3 (1) (3)</p>
<p>10 pcs pack</p> <p>Ø 50 mm overhanging rubber rollers</p>						
		<p>Article</p> <p>VF L35-4 (1) (3)</p> <p>VF L56-4 (1) (3)</p>				