

* The specification subject to change without notice." "The drawing is for reference only.

R13-25

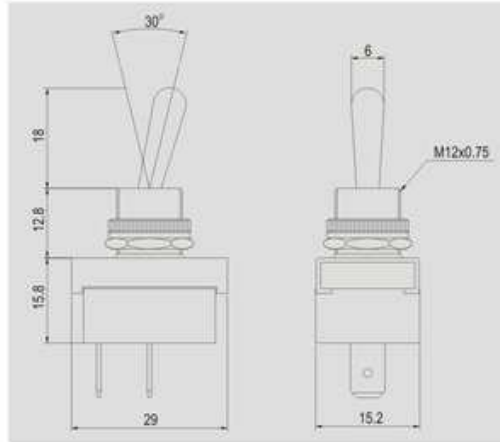

Rating	10A 125V AC 6A 250V AC
Contact resistance	50mΩ Max
Insulation resistance	DC 500V 100MΩ Min
Dielectric strength	AC 1500V 1 minute
Cut-out	 6 mm max

FEATURES

- * MATERIAL: Metal lever and bushing are nickel plated metal. Frame are metal plated. Plastic levers are ABS (UL flame: 94V-2).
- * Indicator plate is optional.
- * Waterproof boot is optional for metal lever.



R13-25

FUNCTION		LEVER	TERMINAL
A 2P SPST	E 6P DPDT	1 Plastic Lever 	0 1 .250" SQ 0 5 SO
B 6P DPDT	2 Metal Lever 		
C 3P SPDT			
D 3P SPDT			

