

Control and Signalling Units

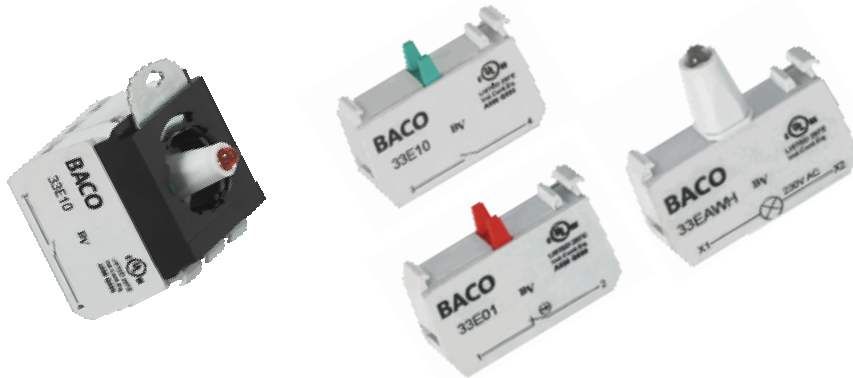

SUMMARY

PAGES

1. Description, use.....	1
2. Range	1
3. Measurement	2
4. Installation	6
5. Technical characteristics	7
6. Compliance and approvals	9
7. Equipment and Accessories	9

1. DESCRIPTION - USE

Contact Block and illuminated block to be used with control unit

2. RANGE (Alternative order code)

. References

33E01 33E10 33E11 33E10Y7 33E01Y7 33EAWL 33EARL 33EAGL
33EABL 33EAYL 33EAWL4 33EARL4 33EAGL4 33EABL4 33EAYL4
33EAWM 33EARM 33EAGM 33EABM 33EAYM 33EAWH 33EARH
33EAGH 33EABH 33EAYH 33ET 33ETT 33EFM 33EFH 33EHC 33ELC
LM11 331E10 331E01 333E01 333E10 333E02 333E20 333E11
333E21 333E12 333E03 334EAWL22 334EARL22 334EAGL22
334EABL22 334EAYL22 334EAWM22 334EARM22 334EAGM22
334EABM22 334EAYH22 334EAWH22 334EARH22 334EAGH22
334EABH22 334EAYH22 333EAWL10 333EARL10 333EAGL10
333EAWL11 333EARL11 333EAGL11 333EAWL20 333EARL20
333EAGL20 333EAWH10 333EARH10 333EAGH10 333EAWH11
333EARH11 333EAGH11 333EAWH20 333EARH20 333EAGH20 33D01
33D10 331ED01 331ED10 33R01 33R10 33EAWL 33RARL 33RAGL
33RABL 33RAYL 33EAWM 33RARM 33RAGM 33RABM 33RAYM
33EAWH 33RARH 33RAGH 33RABH 33RAYH 33RFM 33RFH 331ER01
331ER10 333ER20 333ER01 333ER11 333ER02 331ERAWL 331ERARL
331ERAGL 331ERABL 331ERAYL 331ERAWM 331ERARM 331ERAGM
331ERABM 331ERAYM 331ERAWH 331ERARH 331ERAGH 331ERABH
331ERAYH 333EP02 333EP20 33PAWL 33PARL 33PAWL 33PAYL
33P01 33P10 33P01Y7 33P10Y7 33S01 33S10 33SAWL 33SARL
33SAGL 33SABL 33SAYL 33SAWM 33SARM 33SAGM 33SABM
33SAYM 33SAWH 33SARH 33SAGH 33SABH 33SAYH 33E01C

. Type of use

- . Contact Block
- . LED Module
- . Joystick Block
- . Lamp-test Block
- . Transformer Block
- . Filter Block

. Connection

- . Screw terminals
- . Plug-In terminals
- . Faston terminals
- . Pin style terminals

2. RANGE

. Mounting

- . Front mounting with a clip
- . Base mounting (control station)

. Electrical Rating (Standard IEC 60947-5-1 – max rating , see page 6)

. For screw terminals and plug-in terminals :

- . Alternating current (AC-15): $120\text{ V} \leq U_e \leq 600\text{ V}$
 $6\text{ A} \geq I_e \geq 1,2\text{ A}$
- . Direct current (DC-13): $125\text{ V} \leq U_e \leq 600\text{ V}$
 $0,55\text{ A} \geq I_e \geq 0,1\text{ A}$

. For Pin style connection :

- . Alternating current (AC-15): $120\text{ V} \leq U_e \leq 240\text{ V}$
 $3\text{ A} \geq I_e \geq 1,5\text{ A}$
- . Direct current (DC-13): $125\text{ V} \leq U_e \leq 250\text{ V}$
 $0,22\text{ A} \geq I_e \geq 0,1\text{ A}$

. For Faston terminals :

- . Alternating current (AC-15): $120\text{ V} \leq U_e \leq 240\text{ V}$
 $6\text{ A} \geq I_e \geq 3\text{ A}$
- . Direct current (DC-13): $125\text{ V} \leq U_e \leq 250\text{ V}$
 $0,55\text{ A} \geq I_e \geq 0,27\text{ A}$

. For LED Blocks:

- . 12 to 24 V AC/DC $\pm 10\%$
- . 48 V AC/DC $\pm 10\%$
- . 130 V AC – 8% / +15%
- . 230 V AC $\pm 15\%$

. Minimum operating current :

- . Standard blocks (screws, plug-in, faston, pin style terminals)
 - . $U_e = 24\text{ V DC}$ and $I_e = 5\text{ mA}$
- . Low level contact blocks (screws, pin style)
 - . $U_e = 5\text{ V DC}$ and $I_e = 1\text{ mA}$

3. MEASUREMENT

Screw terminal block , single clip

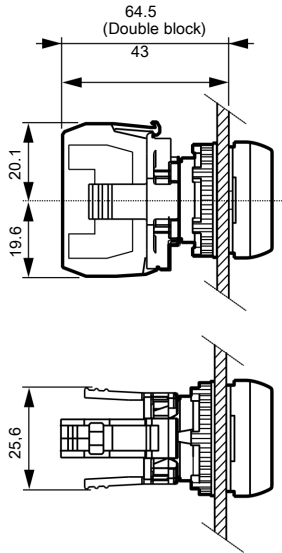

Screw terminal block , 3 position clip

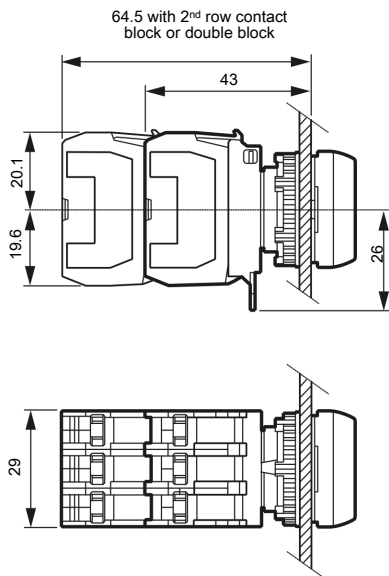

3. MEASUREMENT

Screw terminal block , 5 position clip

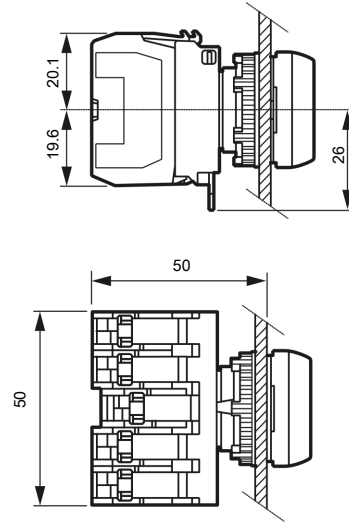

Plug-in terminal block , single clip

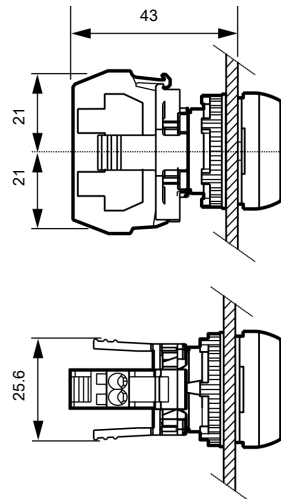

3. MEASUREMENT

Plug-in terminal block , 3 position clip

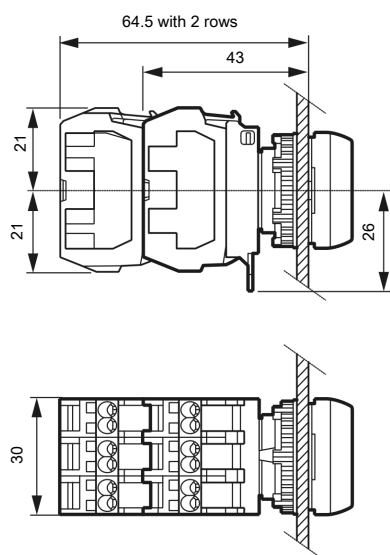

Plug-in terminal block , 5 position clip

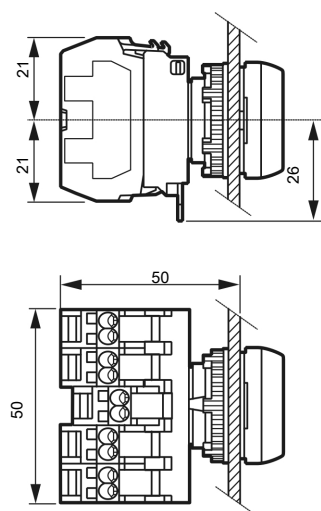

3. MEASUREMENT

Faston terminal block , single clip

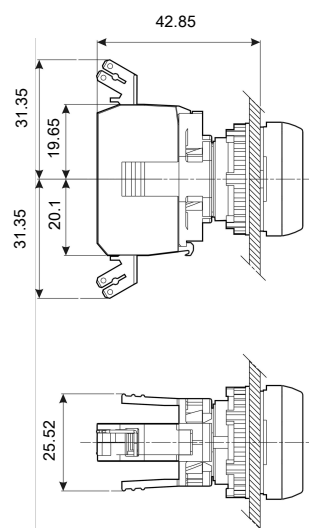

Faston terminal block , 3 position clip

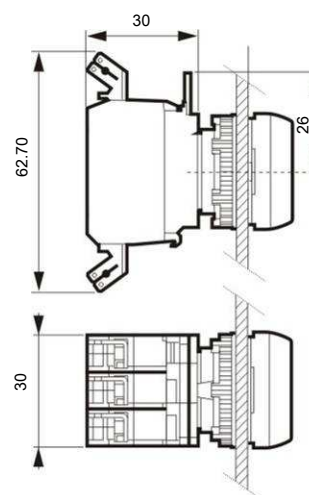

3. MEASUREMENT

Pin-Style terminal, single clip

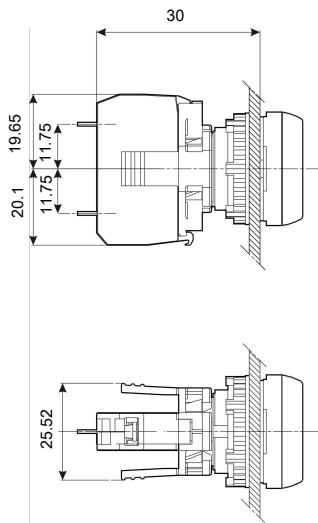

Pin-Style terminal, 3 position clip

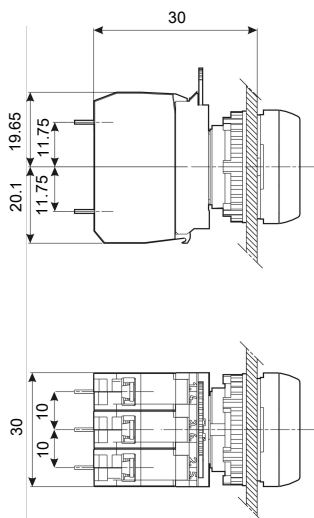

3. MEASUREMENT

Drill plan for Pin-style terminal blocks on Printed Circuit Board (PCB)

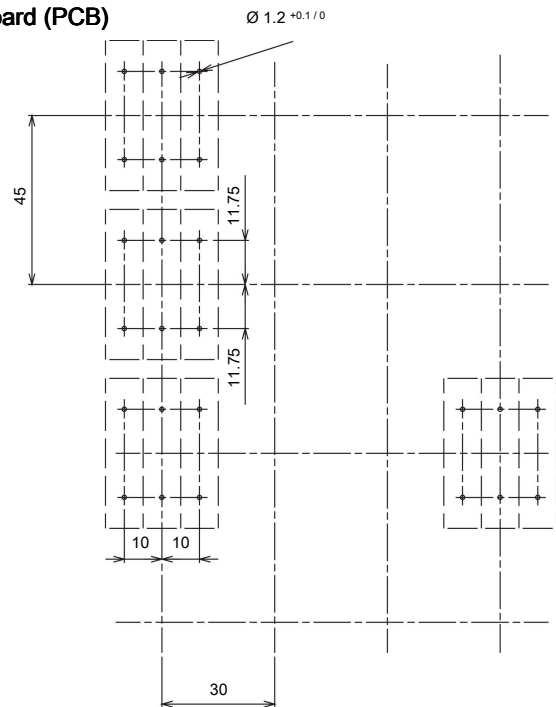

Screw terminal contact block

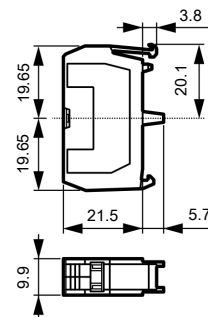

Plug-in terminal contact block

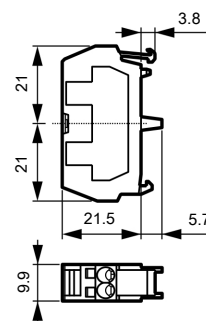

3. MEASUREMENT

Faston terminal contact block

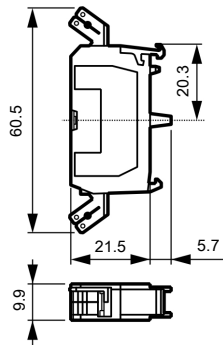

Pin-style terminal contact block

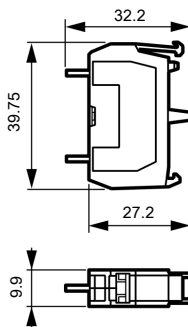

Screw terminal LED block

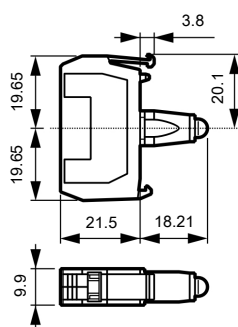

3. MEASUREMENT

Plug-in terminals LED block

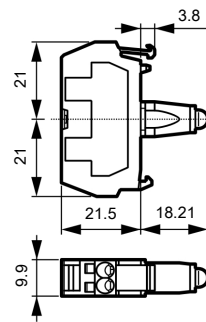

Faston terminal LED block

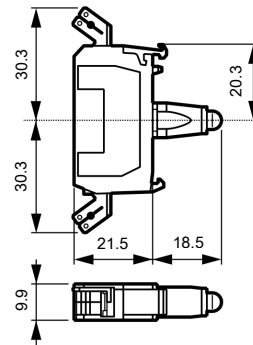

Pin-Style terminals LED block

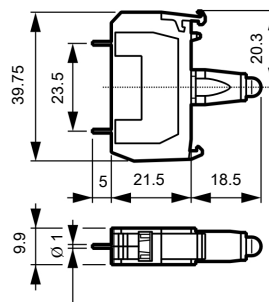

3. MEASUREMENT

Joystick block (screw terminal)

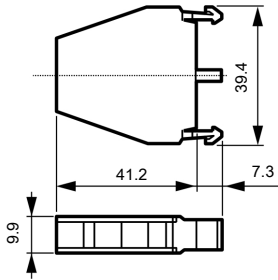

Double block (Screw terminal)

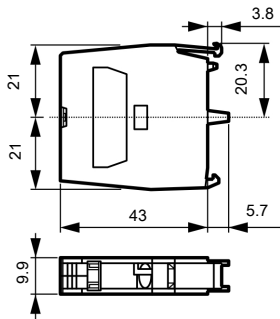

4. INSTALLATION

Front panel mounting :

- . With single clip
- . Clip and head assembly

Clip marker on the top

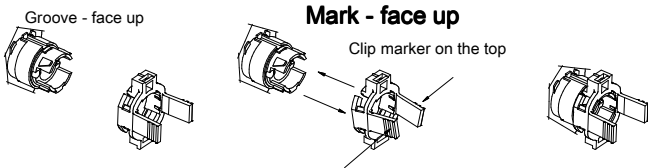

. block assembly / removal on/of clip

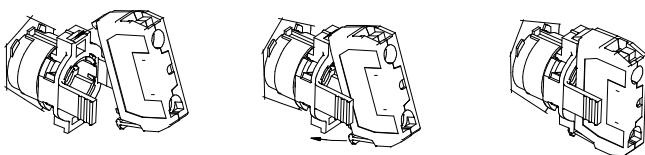

4. INSTALLATION

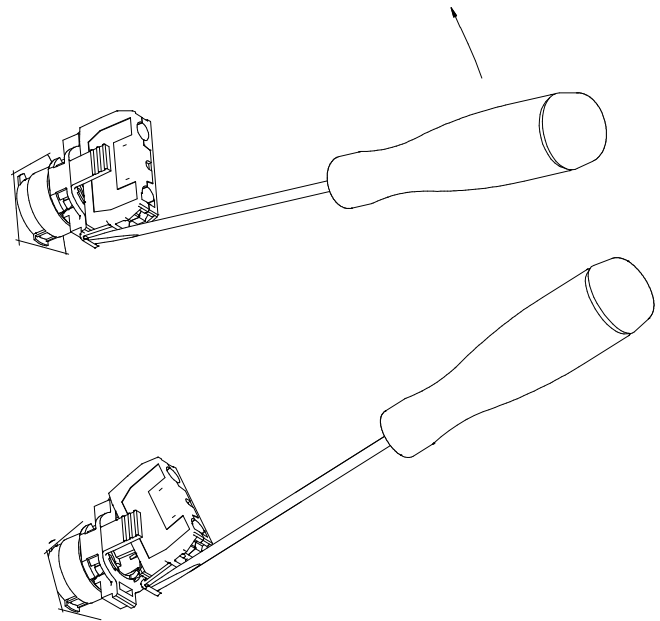

- . with 3 and 5 position clip
- . Clip and head assembly

Slot facing up

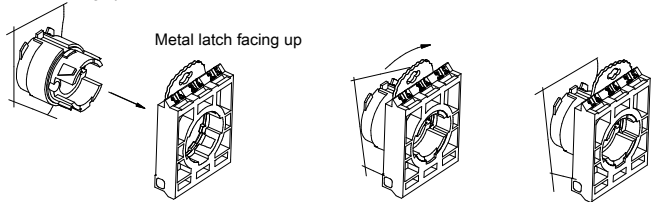

. contact block assembly / removal on/of clip

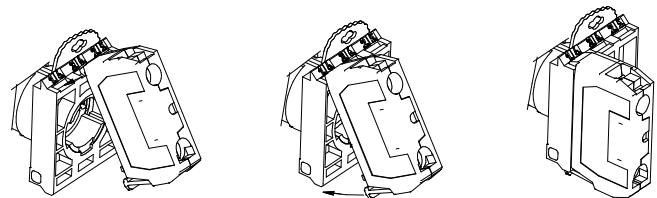

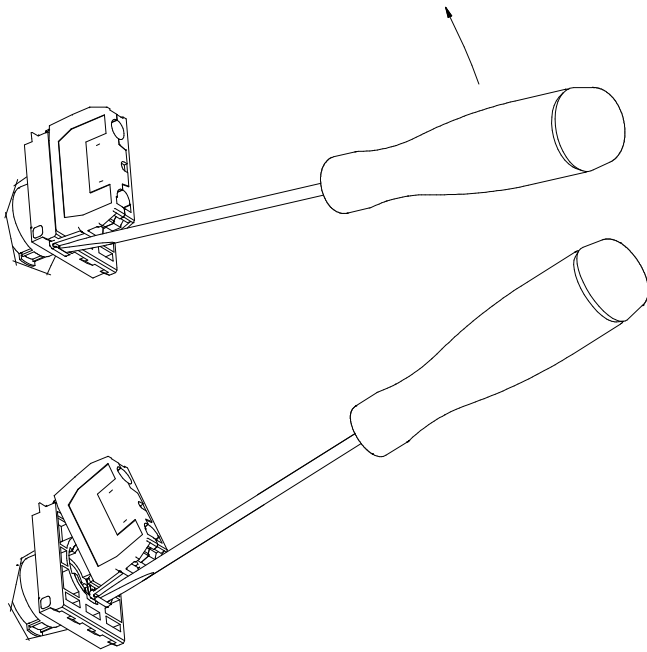
4. INSTALLATION**Control station mounting :**

- . use base mounting contact blocks

Printed circuit board mounting :

- . use Pin-style contact blocks

Current supply :

- . On the back side of the block

Visualization of the contact state:

- . Contact state is visible on the back side of the contact block, mounted block (colour plunger, visible)

Type of wire :

For screw terminal contact blocks (front mounting or base mounting):

- . Solid or stranded wire without ferrule : 2x 0,5 mm² to 2x 2,5 mm²
- . Solid or stranded wire with ferrule : 2 x 0,5 mm² to 2 x 1,5 mm²

For plug-in terminal contact blocks:

- . Solid or stranded wire without ferrule : 2x 0,5 mm² to 2x 2,5 mm²
- . Solid or stranded wire with ferrule : 2 x 0,5 mm² to 2 x 1,5 mm²

For Faston terminal contact blocks :

- . 1 faston clip 6,35 mm or 2 faston clips 2,85 mm

For pin style terminal contact blocks :

- . Ø 1 mm

Connection with screw and plug-in terminals :

- . Terminals protected against direct contact (IP2X)
- . Recommended terminal torque: 1.2 Nm

4. CONNECTION**Tools :**

- . For plug-in terminals, it is advisable to use screwdriver with Flat blade - 2.5 mm
- . For screw terminals, it is advisable to use screwdriver Phillips n°2 or screwdriver with flat blade - 5,5 mm
- . To remove the block it is advisable to use a flat blade screwdriver

Connecting blocks on clips :

		Clip		
		single	3 positions	5 positions
Blocks	1 level	X	X	X
	2 levels		X	

6 and more NO blocks on a 3 position clip are unsuitable with EN418 push and turn mushroom head.

5. TECHNICAL CHARACTERISTICS**Maximum operating current:**

- . For standards blocks (screw or Plug-in terminals)

. AC15 (Alternating current)

- Ue = 120 V Ie = 8 A
- Ue = 230 V Ie = 6 A
- Ue = 400 V Ie = 4,5 A
- Ue = 440 V Ie = 3,5 A
- Ue = 500 V Ie = 2,5 A
- Ue = 690 V Ie = 1 A

. DC13 (Direct current)

- Ue = 24 V Ie = 1,5 A
- Ue = 48 V Ie = 1 A
- Ue = 60 V Ie = 0,7 A
- Ue = 110 V Ie = 0,3 A
- Ue = 230 V Ie = 0,2 A

- . For Pin style terminals blocks

. AC15 (Alternating current)

- Ue = 120 V Ie = 8 A
- Ue = 240 V Ie = 6 A
- Ue = 400 V Ie = 4 A

. DC13 (Direct current)

- Ue = 125 V Ie = 0,22 A
- Ue = 250 V Ie = 0,1 A

- . For Faston terminal blocks

. AC15 (Alternating current)

- Ue = 120 V Ie = 6 A
- Ue = 240 V Ie = 3 A

. DC13 (Direct current)

- Ue = 125 V Ie = 0,55 A
- Ue = 250 V Ie = 0,27 A

5. TECHNICAL CHARACTERISTICS

- . For joystick blocks
- . AC15 (Alternating current)
 - Ue = 60 V Ie = 10 A
 - Ue = 110 V Ie = 6 A
 - Ue = 220 V Ie = 3 A
 - Ue = 380 V Ie = 2 A
 - Ue = 500 V Ie = 1,5 A
 - Ue = 600 V Ie = 1,2 A
- . DC13 (Direct current)
 - Ue = 24 V Ie = 2,5 A
 - Ue = 48 V Ie = 1,4 A
 - Ue = 60 V Ie = 1 A
 - Ue = 110 V Ie = 0,55 A
 - Ue = 220 V Ie = 0,27 A
 - Ue = 300 V Ie = 0,2 A

Conventional thermal current in enclosure :

- . For standards blocks (screw or Plug-in terminals)
 - . Ith = 16 A in AC
 - . Ith = 2,5 A in DC
- . For Faston terminals blocks
 - . Ith = 10 A in AC
 - . Ith = 2,5 A in DC
- . For Pin style terminal blocks
 - . Ith = 5 A in AC
 - . Ith = 1 A in DC

Rated insulation voltage :

- . For screw terminal contact blocks
 - . Ui = 690 V according to IEC 60947-5-1
 - . Ui = 600 V according to UL508
- . For faston terminal blocks
 - . Ui = 320 V according to IEC 60947-5-1
 - . Ui = 300 V according to UL 508
- . For LED blocks
 - . Ui = 300 V according to IEC 60947-5-1
- . For Pin-style terminal blocks
 - . Ui = 250 V according to IEC 60947-5-1

Pollution degree :

- . 3

Rated impulse withstanding voltage :

- . For standard contact and faston blocks
 - . Uimp = 6kV according to IEC 60947-5-1
- . For LED and Pin-style terminal blocks
 - . Uimp = 4kV according to IEC 60947-5-1

LED blocks :

- . Life time:
 - red and yellow 100 000 hours at 25°C under Un
 - others colours 50 000 hours at 25°C under Un
- . LED power consumption:
 - . For 24 V = 20 mA
 - . For 48 V = 15 mA
 - . For 130 V = 20 mA
 - . For 230 V = 16 mA

5. TECHNICAL CHARACTERISTICS

- . Operating voltage : 12, 24, 48, 130, 230 V
- . Frequency: 50 or 60 Hz
- . Electromagnetic compatibility :
 - . Electrostatic discharge immunity test according test IEC 61000-4-2 level 2
 - . Radiated, radio-frequency, electromagnetic field immunity test according to IEC 61000-4-3 level 3
 - . Electrical fast transient/burst immunity test according to IEC 61000-4-4 :
 - . Level 2 for Un = 24 to 48 V
 - . Level 3 for Un = 110 to 230 V
 - . Surge immunity test 1,2 / 50 µs according to IEC 61000-4-5 :
 - . Level 2 for Un = 24 to 48 V
 - . Level 3 for Un = 110 to 230 V
 - . Immunity to conducted disturbances, induced by radio-frequency fields according to IEC 61000-4-6
 - . Voltage dips, short interruptions and voltage variation immunity tests according to IEC 61000-4-11 only on models Un = 100 to 230V

Protection Fuse :

- . For the standards blocks
 - . 10 A gG according to IEC 60947-5-1
- . For pin-style terminals blocks
 - . 6 A gG according to IEC 60947-5-1

Mechanical life :

- . For screw, Faston and pin-style terminals blocks
 - . 5 000 000 cycles

Electrical operating life :

- . For screw, faston and pin-style terminal blocks
 - . 1 000 000 cycles:
 - AC15 – B300
 - . Ue = 120 V Ie = 3 A
 - . Ue = 240 V Ie = 1,5 A
 - DC13 – R300
 - . Ue = 125 V Ie = 0,22 A
 - . Ue = 250 V Ie = 0,1 A

Operating Temperature :

- . minimum : -25°C maximum : +70°C

5. TECHNICAL CHARACTERISTICS**Storage temperature :**

- . minimum : -40°C maximum : +70°C

Cold test :

- . according to IEC 60068-2-1

Dry heat test :

- . according to IEC 60068-2-2

Constant humidity test :

- . according to IEC 60068-2-3 / IEC 60068-2-30

Glow wire test :

- . 960°C on the blocks

Marking :

- . Front part marking NO plug-in terminal block

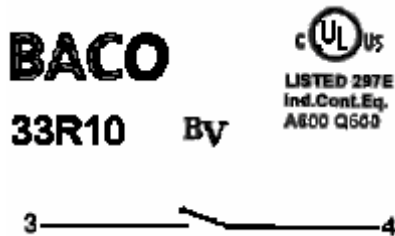

- . Back marking NO Block

IEC/EN 60947-5-1
Ith 10A
Ui 690V AC
AC15 240V 3A



- . Front marking - NC screw terminal block

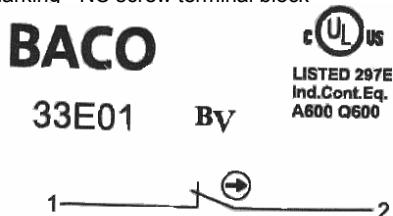

- . Rear marking - NO screw terminal block

IEC/EN 60947-5-1
Ith 10A
Ui 690V AC
AC15 240V 3A

Quantity-packaged :

- . 1, 5, 10 or 20

Protection degree against direct contacts:

- . IP2X according to IEC 60529 (screw and plug-in terminals)

6. CONFORMITY AND ACCREDITATION**Standard compliances:**

- . IEC 60947-5-1
- . IEC 60947-5-5
- . IEC 60947-5-4
- . UL 508
- . CSA 22.2

Approvals

- . cULus and Bureau Véritas (Marine rules)
- . BBJ

Environmental respect.

- . Compliant to the directive 2002/95/CE of 27/01/03 « RoHS » restricts the use of hazardous substances like lead, mercury, cadmium, hexavalent chromium, poly brominated diphenils (PBBs) and poly brominated diphenils ethers (PBDEs) since July 1st 2006
- . Compliant to the directives 91/338/CEE of 18/06/91 and decree 94-947 of 27/07/04
- . Compliant to the directive 72/23 CEE and 89/339 CEE on the CE marking
- . Compliant to the directive 73/374 CEE (98389 rule of the 15/05/98)
- . Compliant to the directive 76/769/CEE concerning hazardous substances prohibition

Plastic materials :

- . Plastic material body halogen free
- . head : polyamid
- . plunger : polyamid
- . shroud : silicone
- . enclosure : polycarbonate

Metallic materials :

- . Terminals : Steel
- . contact : Silver
- . golden contact : gold flash 2,5 µm

Packaging:

- . Packaging development and manufacturing conform to the decree 98-638 of 20/07/98 and to the directive 94/62/CE

7. EQUIPEMENT AND ACCESSORIES**. Specials blocks :**

- For joystick (screw terminals)
- Lamp test (screw terminals)
- transformer block (screw terminals)
- filter block (screw terminals or plug-in terminals)
- junction block (screw terminals)
- empty block

. Accessories

- single clip
- 3 position clip
- 5 position clip

