

THIS DRAWING IS UNPUBLISHED. RELEASED FOR PUBLICATION 30/OCT , 2003.
 © COPYRIGHT 2003 BY TYCO ELECTRONICS CORPORATION. ALL RIGHTS RESERVED.

LOC	DIST	REVISIONS			
P	LTR	DESCRIPTION	DATE	DWN	APVD
C		EBDO-0108-05	15/06/05	AM	FWK

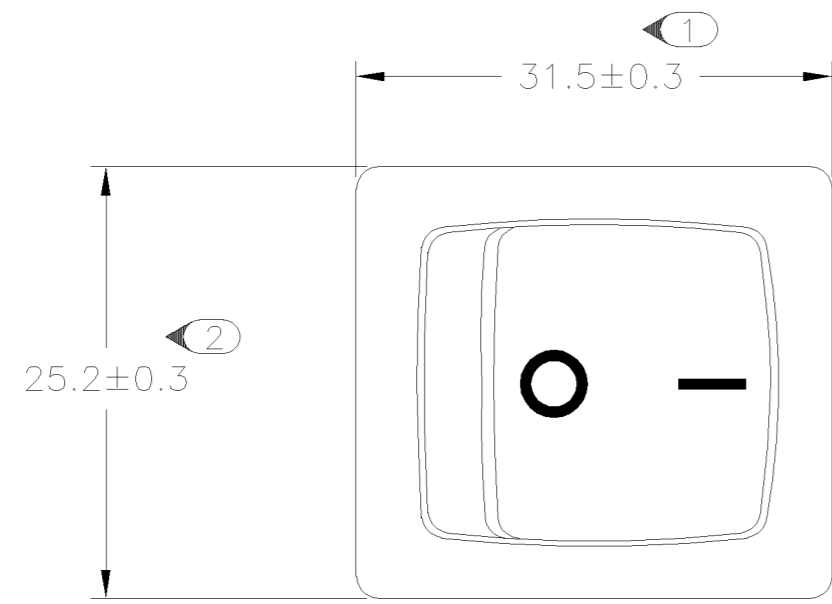

PANEL CUT OUT

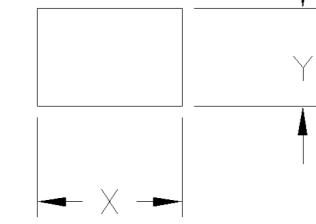



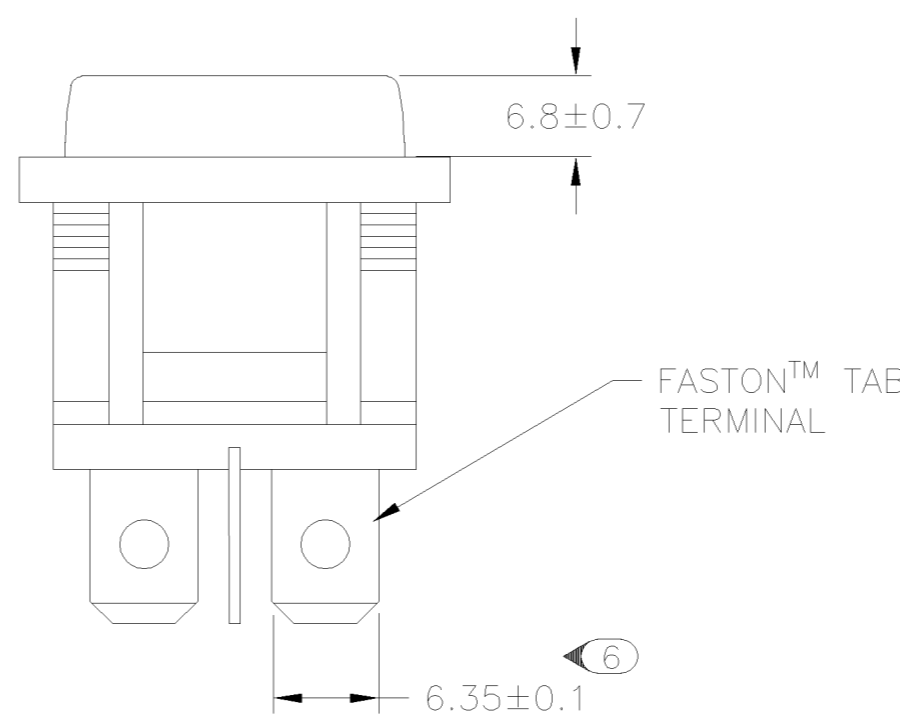
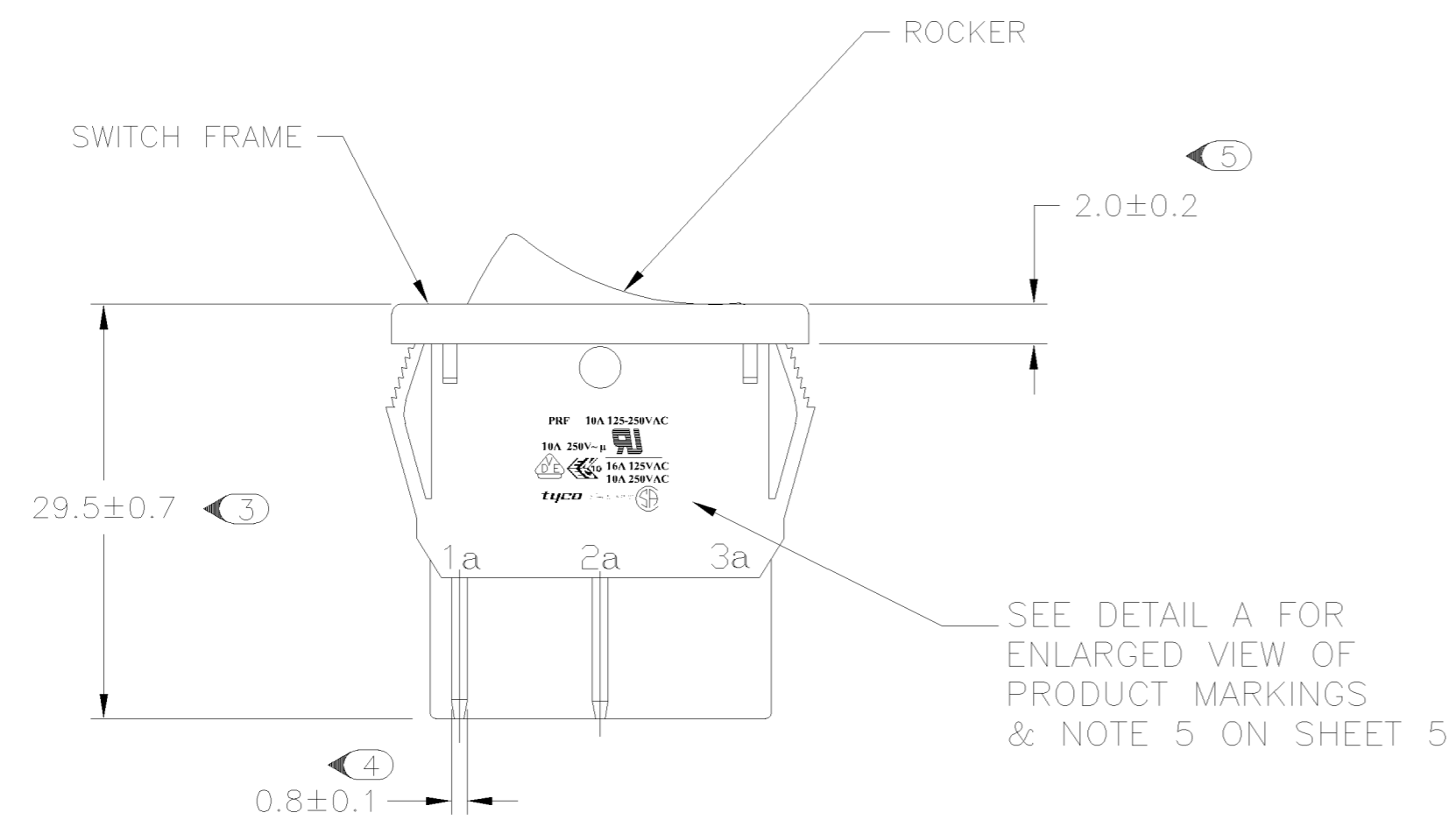

2.00-3.00	30.20	22.20
1.25-2.00	30.20	22.20
0.75-1.25	30.20	22.20
PANEL THICKNESS	X	Y

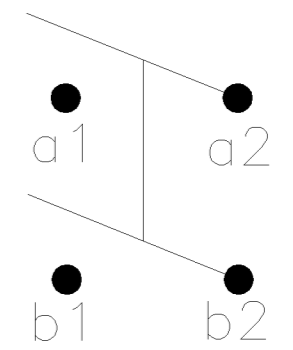

CIRCUIT DIAGRAM

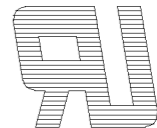

**PRODUCT MARKING
DETAIL A**

PRF 10A 125-250VAC
10A 250V~μ 
  **16A 125VAC**
10A 250VAC
tyco / *Electronics* 



1634201-2 SHOWN ON-OFF

THIS DRAWING IS A CONTROLLED DOCUMENT.		DWN S.SHACKSON 28JAN2003	tyco Tyco Electronics Corporation	
DIMENSIONS: MM		CHK H.KAUTZ 28JAN2003	Harrisburg, PA 17057	
TOLERANCES UNLESS OTHERWISE SPECIFIED:		APVD H.KAUTZ 28JAN2003	NAME POWER ROCKER SWITCH, 30.2mm X 22.2mm	
0 PLC ± -	1 PLC ± 0.5	PRODUCT SPEC	PANEL CUT-OUT SIZE, DOUBLE POLE, SINGLE THROW, NON-ILLUMINATED	
2 PLC ± -	3 PLC ± -	APPLICATION SPEC	SIZE A2	CAGE CODE 00779
4 PLC ± -	ANGLES ± -	FINISH	DRAWING NO C=1634201	RESTRICTED TO -
MATERIAL	1	2	SCALE 3:1	SHEET 1 OF 5
CUSTOMER DRAWING		WEIGHT -	REV C	

THIS DRAWING IS UNPUBLISHED. RELEASED FOR PUBLICATION 30/OCT ,2003.
 © COPYRIGHT 2003 BY TYCO ELECTRONICS CORPORATION. ALL RIGHTS RESERVED.

LOC	DIST	REVISIONS					
E	B	P	LTR	DESCRIPTION	DATE	DWN	APVD
		-		SEE SHEET 1	-	-	-

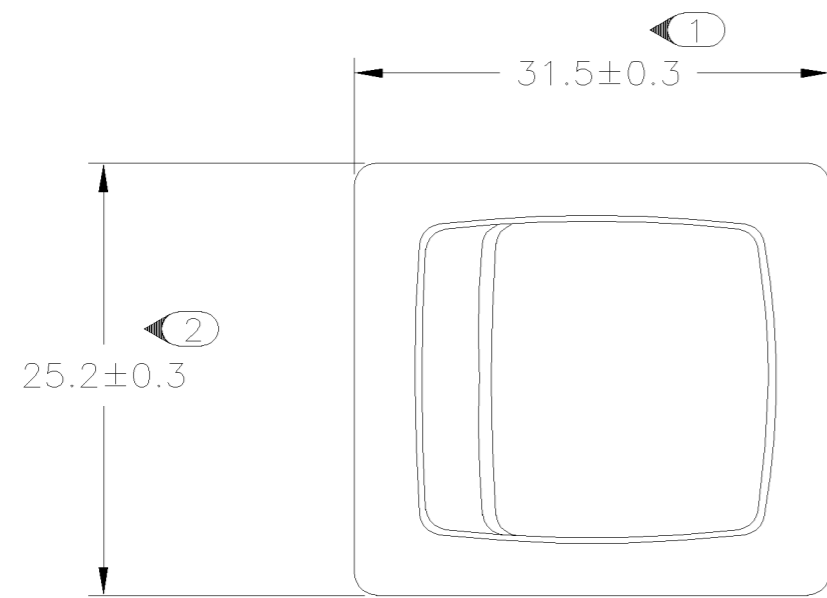

PANEL CUT OUT

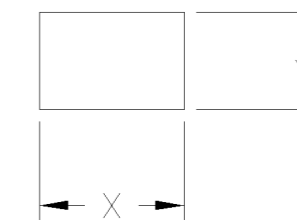

2.00-3.00	30.20	22.20
1.25-2.00	30.20	22.20
0.75-1.25	30.20	22.20
PANEL THICKNESS	X	Y

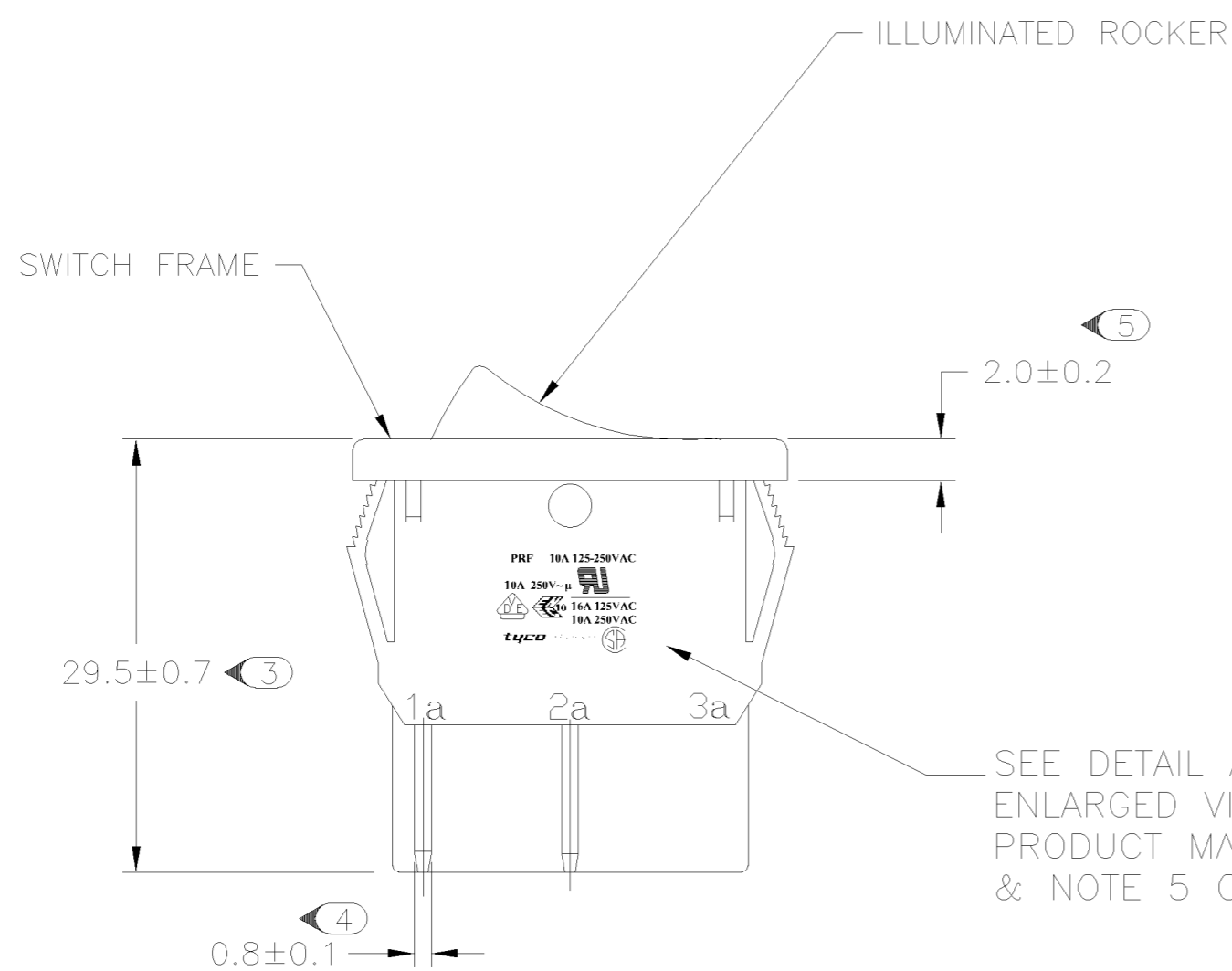

SEE DETAIL A FOR ENLARGED VIEW OF PRODUCT MARKINGS & NOTE 5 ON SHEET 5

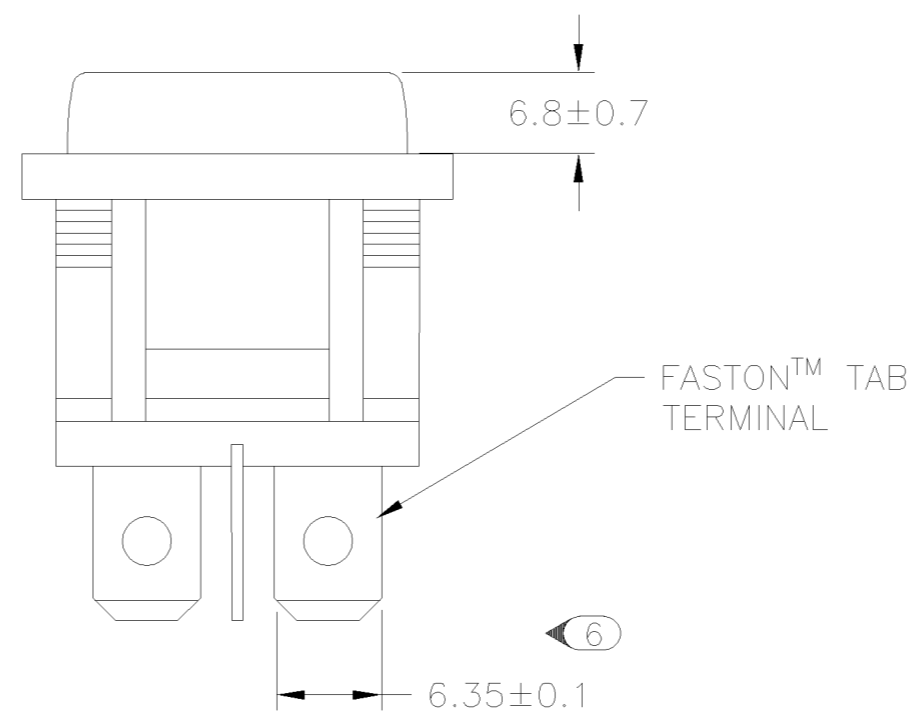

CIRCUIT DIAGRAM

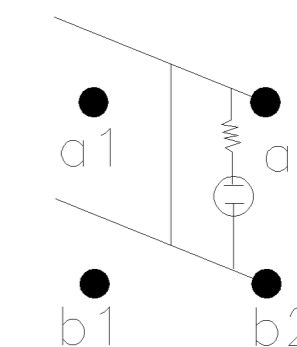

PRODUCT MARKING

DETAIL A

PRF 10A 125-250VAC

10A 250V~μ

10 16A 125VAC
10A 250VAC

tyco / *Electronics*

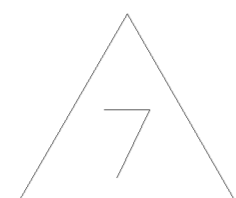

1634201-5 SHOWN ON-OFF
GREEN ILLUMINATED

THIS DRAWING IS A CONTROLLED DOCUMENT.		DWN S.SHACKSON 28JAN2003	tyco Tyco Electronics Corporation	
DIMENSIONS: MM		CHK H.KAUTZ 28JAN2003	Electronics Harrisburg, PA 17057	
TOLERANCES UNLESS OTHERWISE SPECIFIED:		APVD H.KAUTZ 28JAN2003	NAME POWER ROCKER SWITCH, 30.2mm X 22.2mm	
0 PLC ± -		PRODUCT SPEC	PANEL CUT-OUT SIZE, DOUBLE POLE, SINGLE THROW, ILLUMINATED	
1 PLC ± 0.5		APPLICATION SPEC	RESTRICTED TO	
2 PLC ± -		WEIGHT	SIZE A2	CAGE CODE 00779
3 PLC ± -		FINISH	DRAWING NO C=1634201	SCALE 3:1
4 PLC ± -			SHEET 2 OF 5	REV C
ANGLES ± -				
MATERIAL				
CUSTOMER DRAWING				

THIS DRAWING IS UNPUBLISHED. RELEASED FOR PUBLICATION 30/OCT ,2003.
 © COPYRIGHT 2003 BY TYCO ELECTRONICS CORPORATION. ALL RIGHTS RESERVED.

LOC		DIST		REVISIONS			
P	LTR	DESCRIPTION	DATE	DWN	APVD		
-	-	SEE SHEET 1	-	-	-		

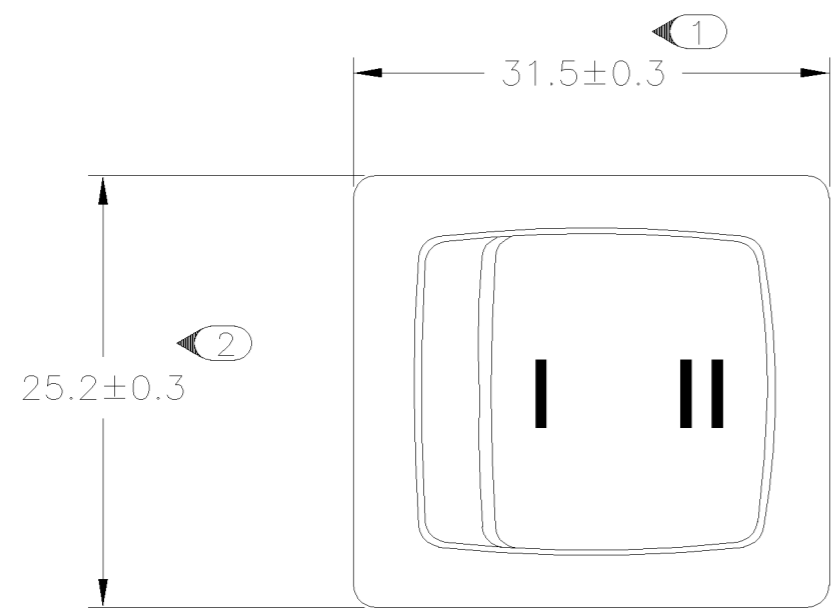

PANEL CUT OUT

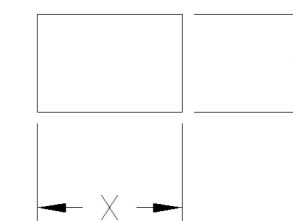

2.00-3.00	30.20	22.20
1.25-2.00	30.20	22.20
0.75-1.25	30.20	22.20
PANEL THICKNESS	X	Y

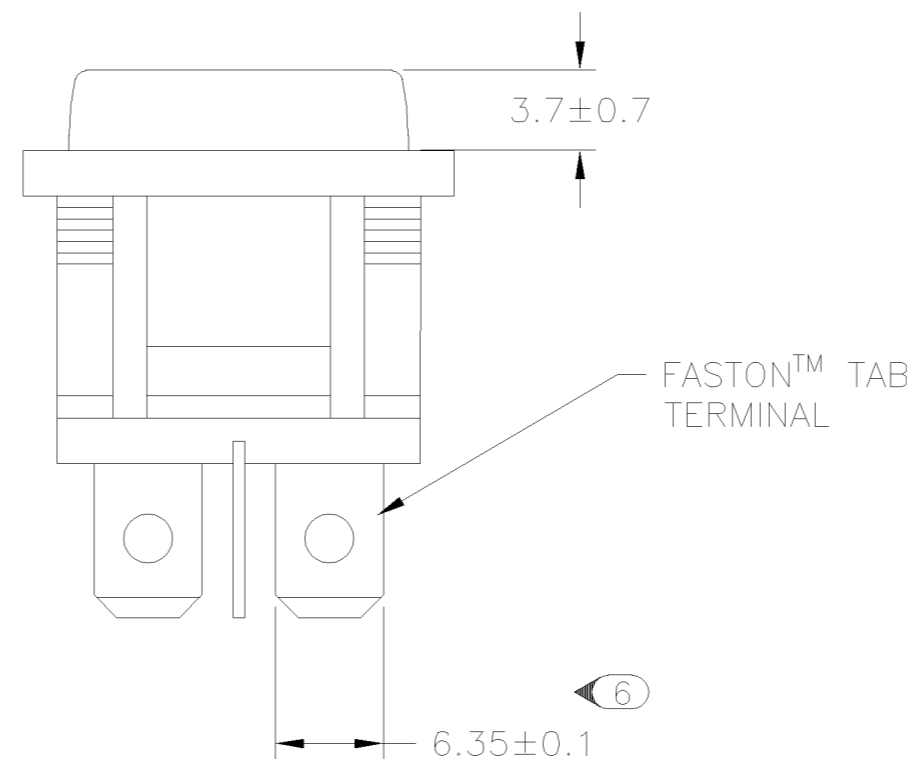
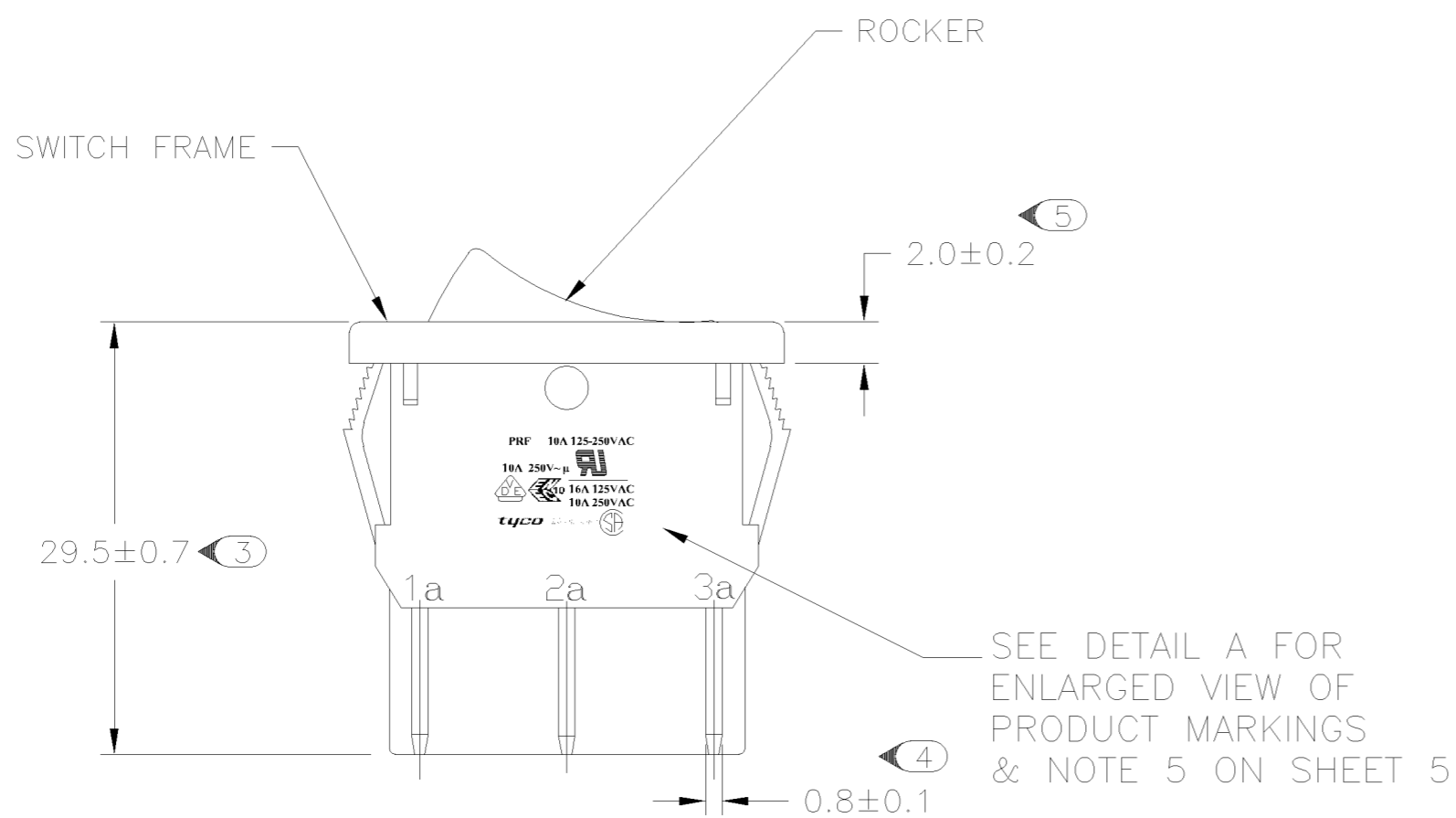

CIRCUIT DIAGRAM

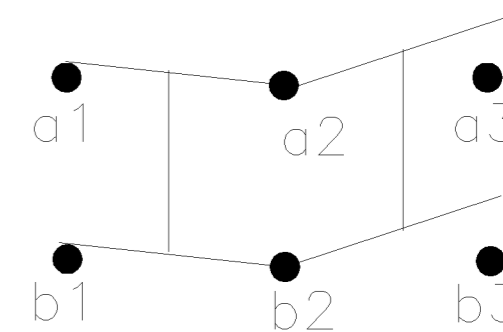

**PRODUCT MARKING
DETAIL A**

PRF 10A 125-250VAC
10A 250V~μ
16A 125VAC
10A 250VAC
tyco / *Electronics*

1634201-8 SHOWN ON-ON

THIS DRAWING IS A CONTROLLED DOCUMENT.		DWN S.SHACKSON 28JAN2003	tyco Tyco Electronics Corporation	
DIMENSIONS: MM		CHK H.KAUTZ 28JAN2003	Harrisburg, PA 17057	
TOLERANCES UNLESS OTHERWISE SPECIFIED:		APVD H.KAUTZ 28JAN2003	NAME POWER ROCKER SWITCH, 30.2mm X 22.2mm	
0 PLC ± -		PRODUCT SPEC	PANEL CUT-OUT SIZE, DOUBLE POLE, NON-ILLUMINATED	
1 PLC ± 0.5		APPLICATION SPEC	SIZE A2	RESTRICTED TO
2 PLC ±		WEIGHT -	CAGE CODE 00779	DRAWING NO C=1634201
3 PLC ±		MATERIAL 1	SCALE 3:1	
4 PLC ±		FINISH 2	SHEET 3 OF 5	REV C
ANGLES ± -				
FINISH				

THIS DRAWING IS UNPUBLISHED. RELEASED FOR PUBLICATION 30/OCT ,2003.
 © COPYRIGHT 2003 BY TYCO ELECTRONICS CORPORATION. ALL RIGHTS RESERVED.

LOC		DIST		REVISIONS			
P	LTR	DESCRIPTION	DATE	DWN	APVD		
-	-	SEE SHEET 1	-	-	-		

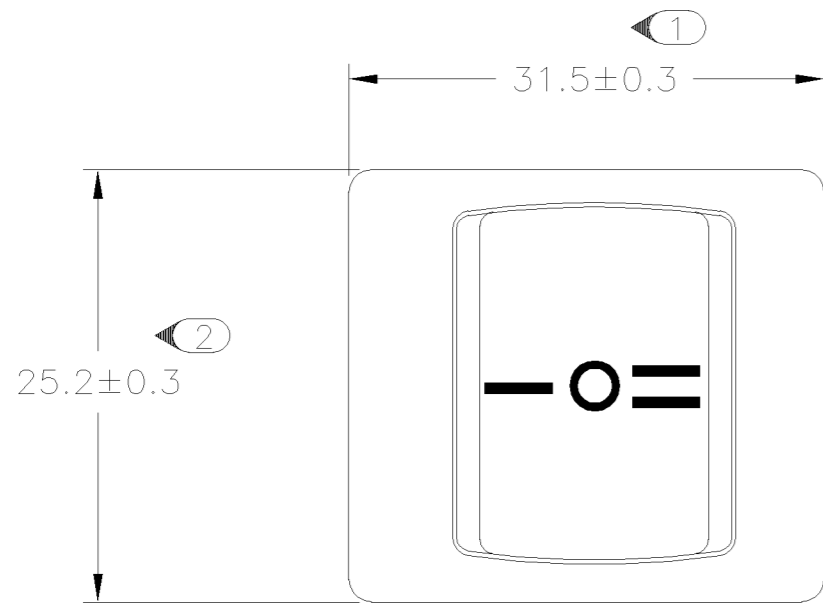

PANEL CUT OUT

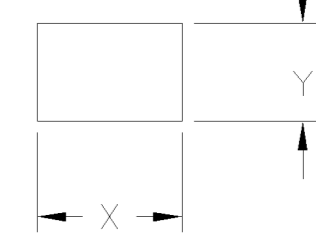

2.00-3.00	30.20	22.20
1.25-2.00	30.20	22.20
0.75-1.25	30.20	22.20
PANEL THICKNESS	X	Y

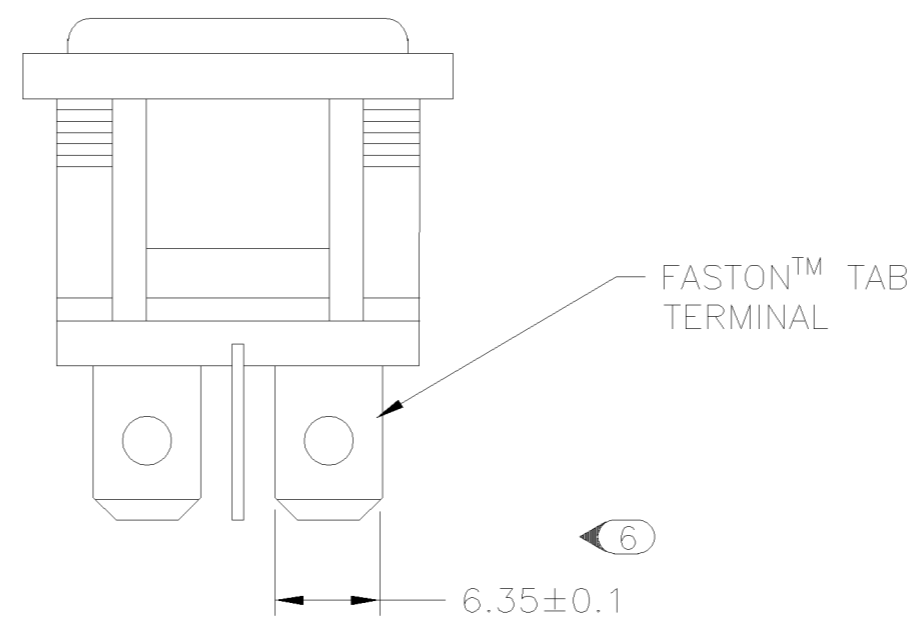
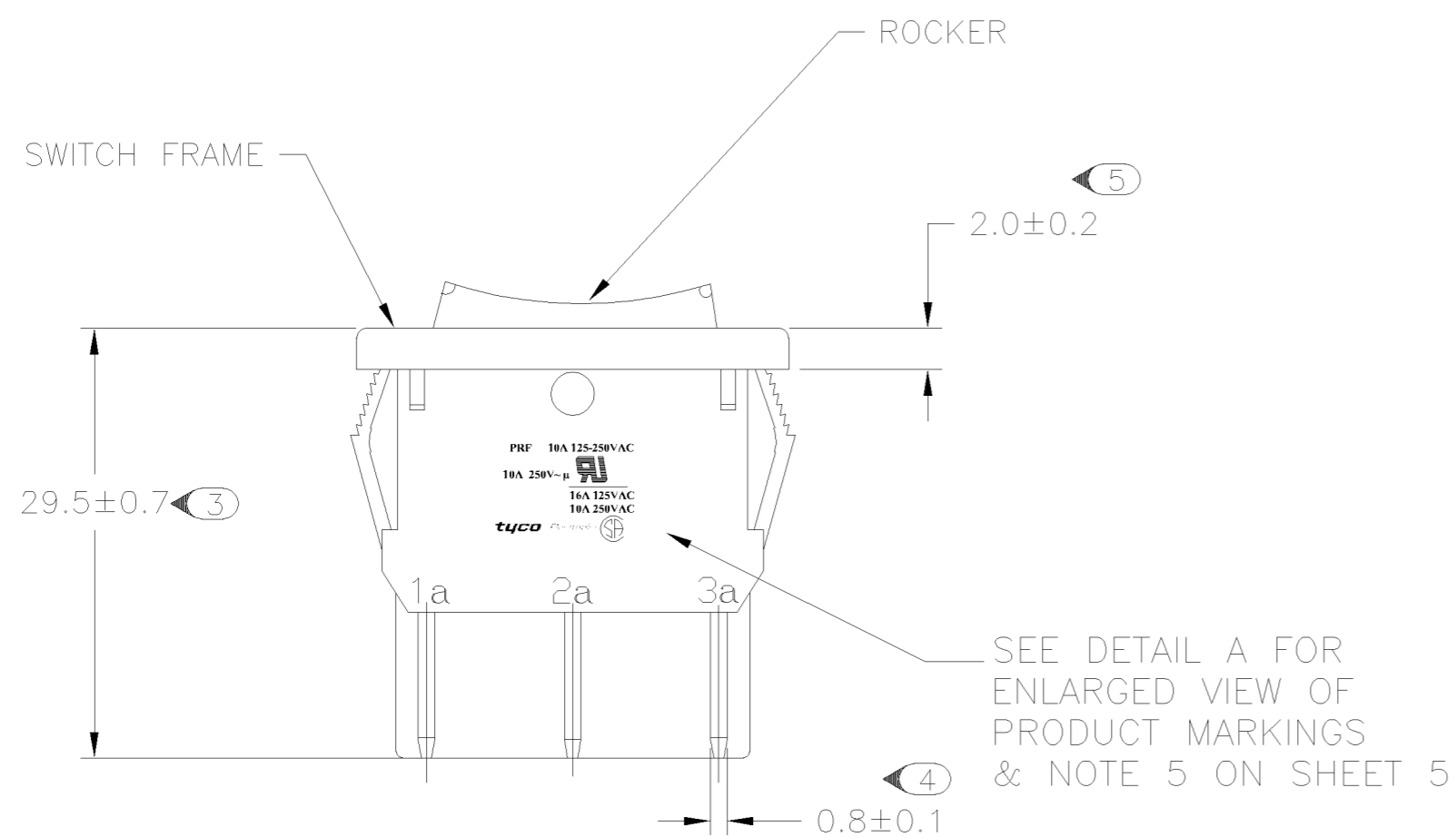

CIRCUIT DIAGRAM

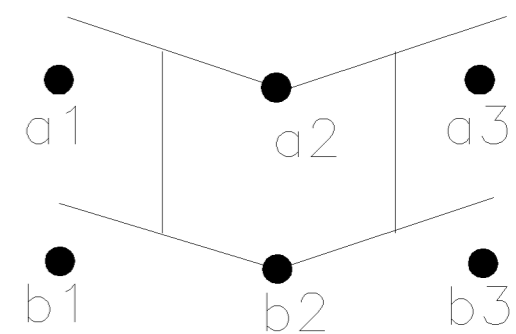

PRODUCT MARKING
DETAIL A

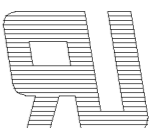
PRF 10A 125-250VAC
10A 250V~μ 
16A 125VAC
10A 250VAC

tyco / *Electronics* 

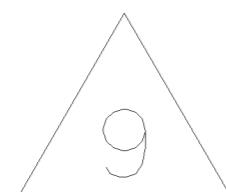

1-1634201-2 SHOWN ON-OFF-ON

THIS DRAWING IS A CONTROLLED DOCUMENT.		DWN S.SHACKSON 28JAN2003	tyco Tyco Electronics Corporation	
DIMENSIONS: MM		CHK H.KAUTZ 28JAN2003	Harrisburg, PA 17057	
TOLERANCES UNLESS OTHERWISE SPECIFIED:		APVD H.KAUTZ 28JAN2003	NAME POWER ROCKER SWITCH, 30.2mm X 22.2mm PANEL CUT-OUT SIZE, DOUBLE POLE, NON-ILLUMINATED	
0 PLC ± -		PRODUCT SPEC	SIZE CAGE CODE DRAWING NO RESTRICTED TO	
1 PLC ± 0.5		APPLICATION SPEC	A2 00779 C=1634201 -	
2 PLC ±		WEIGHT	SCALE SHEET OF REV	
3 PLC ±		CUSTOMER DRAWING	3:1 4 OF 5 C	
4 PLC ±				
ANGLES ± -				
FINISH				

LOC	DIST	REVISIONS			
P	LTR	DESCRIPTION	DATE	DWN	APVD
-	-	SEE SHEET 1	-	-	-

ALCOSWITCH PART NUMBER

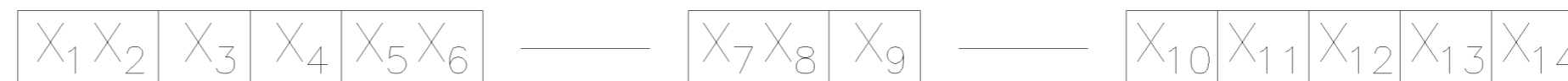

SWITCH TYPE: X1X2 = PR - POWER ROCKER

SECONDARY ROCKER COLOR: X12 = Ø - NOT APPLICABLE

NOMINAL PANEL CUT OUT SIZE: X3 = F - 30.2X22.2 [.1.189x.874]

- B - BLACK
- G - GREEN
- R - RED
- W - WHITE

NUMBER OF POLES: X4 = D - DOUBLE

SWITCH FUNCTION: X5X6 = A1 -
B1 -
D1 -
D3 -

LEGEND TEXT PATTERN: X13 =



CURRENT RATING: X7X8 = 16 -

LEGEND TEXT COLOR: X14 = Ø - NOT APPLICABLE

- G - GREEN
- R - RED
- B - BLACK
- W - WHITE

TERMINAL TYPE: X9 = F - FASTON™ TAB

FRAME COLOR: X10 = B - BLACK
W - WHITE

ROCKER COLOR: X11 = B - BLACK
G - GREEN
R - RED
Y - YELLOW

MATERIALS:
 HOUSING FRAME: NYLON 66.
 ACTUATOR: NYLON 66/ PC(ILLUMINATED)
 TERMINALS C1100R-1/2H WITH SILVER PLATED CONTACTS
 AgALLOY

FINISH:
 TERMINAL, ACTIVE CONTACTOR: 1.0µm [.000039] SILVER
 PLUNGER: 3.0µm[.000118] NICKEL

3. ELECTRICAL SPECIFICATIONS:
 CONTACT RESISTANCE : 50m ohm Max
 DIELECTRIC STRENGTH : AC 1500V, 1 MINUTE
 OPERATION TEMPERATURE: -20°C~85°C
 INSULATION R: DC 500V 100M ohm MIN

CURRENT AND VOLTAGE 16A@125VAC/10A@250VAC

5. ELECTRICAL RATINGS, APPROVED AGENCY LOGOS, TYCO ELECTRONICS LOGO AND PART NUMBER CAN APPEAR ON EITHER SIDE. (FOR FULL DETAIL SEE INDIVIDUAL DRAWING)

ON-OFF, WITH OPAQUE, SINGLE-COLOR ROCKER BUTTON.

ON-OFF, WITH TRANSPARENT, LAMP-ILLUMINATED ROCKER BUTTON.

ON-ON, WITH OPAQUE, SINGLE-COLOR ROCKER BUTTON.

ON-OFF-ON, WITH OPAQUE, SINGLE-COLOR ROCKER BUTTON.

10. PACKAGING TO CONFORM WITH TYCO SPEC. 107-115

11. REFER TO QIP DIMENSIONAL REPORT

1	PRFDA1-16F-BB000	0-1634201-1
1	PRFDA1-16F-BB0BW	0-1634201-2
1	PRFDA1-16F-BB0CW	0-1634201-3
2	PRFDB1-16F-BR000	0-1634201-4
2	PRFDB1-16F-BG000	0-1634201-5
2	PRFDB1-16F-BY000	0-1634201-6
3	PRFDD1-16F-BB000	0-1634201-7
3	PRFDD1-16F-BB0DW	0-1634201-8
3	PRFDD1-16F-BB0EW	0-1634201-9
4	PRFDD3-16F-BB000	1-1634201-0
4	PRFDD3-16F-BB0EW	1-1634201-1
4	PRFDD3-16F-BB0GW	1-1634201-2
SHEET REF	ALCOSWITCH PART NUMBER.	TYCO PART NUMBER.

THIS DRAWING IS A CONTROLLED DOCUMENT.		DWN S.SHACKSON 28JAN2003	tyco Tyco Electronics Corporation Harrisburg, PA 17057	
DIMENSIONS: MM		CHK H.KAUTZ 28JAN2003	NAME POWER ROCKER SWITCH, 30.2mm X 22.2mm	
TOLERANCES UNLESS OTHERWISE SPECIFIED:		APVD K.KAUTZ 28JAN2003	RESTRICTED TO	
0 PLC ± -		PRODUCT SPEC	SIZE	
1 PLC ± 0.30[.012]		APPLICATION SPEC	CAGE CODE	
2 PLC ± 0.05[.002]		NOT APPLICABLE	DRAWING NO	
3 PLC ± -		NOT APPLICABLE	A2 00779 C=1634201	
4 PLC ± -		WEIGHT	SCALE	
ANGLES ± -		-	3:1	
FINISH		CUSTOMER DRAWING	SHEET 5 OF 5	
			REV C	