

# APEM

## 3000 Series Contactless Joysticks



CLASS LEADING INSTALLED DEPTH <math>< 19\text{ mm}</math> - HALL EFFECT SENSING

ONE, TWO OR THREE AXES - 5V OR 3.3V OPERATION

EMC SHIELDED - ANALOGUE OR PWM OUTPUTS

NEXT GENERATION METAL MECHANISMS



# 3000 SERIES - CONTACTLESS JOYSTICKS

## PRODUCT OVERVIEW

### GENERAL DESCRIPTION

The 3000 Series is the very latest generation in high precision contactless joysticks. With a class leading installed depth of <19mm, it is available in one, two or three axes formats. Long trouble-free life is assured with the latest hall effect technology, providing a range of analogue signals or custom PWM output options. The 3000 Series also delivers a radically improved mechanism construction, that is specifically designed for increased robustness, strength and performance.

As well as all of the features you would expect from the very latest in joystick technology, the patented design of the 3000 Series introduces a number of new functions and product enhancements :

- **SHALLOW INSTALLED DEPTH** - Truly class leading depth, <19mm below panel.
- **METAL BALL-PIVOT MECHANISM** - Tested to withstand far greater forces than older generations of plastic & gimbal style mechanisms.
- **LOW VOLTAGE (3.3V) OPTIONS**
- **PWM OUTPUT OPTIONS**
- **DUAL (REDUNDANT) OUTPUT OPTIONS** - With either the same or inverted polarity.
- **CENTRE DETECT OUTPUT**
- **HALL EFFECT SENSING** - Latest technology, a reduced part count and an ease of integration.
- **HIGH EMC IMMUNITY** - Integral shielding, as standard.
- **PRE-WIRED** - Offered as standard with cables and connectors, factory fitted.
- **SIGNIFICANTLY REDUCED PART COUNT** - The vastly simplified design assures reliability over life.
- **MANY CONFIGURATION OPTIONS** - Our largest ever selection of options, as standard.
- **MORE HANDLES** - Offered as standard with a huge range of handles (please refer to separate handle guide datasheet).
- **HIGHLY FLEXIBLE** - The 3000 Series is designed to allow for further customisation. Differing shafts, heights, forces and outputs are all easily achievable with the 3000 Series. For further details of how we can make our joystick more suited to your application, please contact Apem.

# 3000 SERIES - CONTACTLESS JOYSTICKS

## CONFIGURATIONS & OUTPUTS

### FIVE CONFIGURATION OPTIONS

When considering a 3000 Series the first decision is what type of outputs are needed for your application. There are five output configurations offered as standard:

- 1. For general purpose applications** operating on a 5V supply, this configuration provides **one proportional output per axis**, a centre tap reference and a separate centre detect output. Customers may choose from a wide range of possible options including different: voltage outputs (gains), handles, bezels and limiters.
- 2. For low voltage applications** the 3000 Series may be specified to operate with a **supply of 3.3V**. This version is offered as standard with +/-50% gain, yielding a voltage span from 0V (South) to 3.3V (North). No centre tap or centre detect outputs are offered, however customers may continue to determine their preference of limiter, handle & bezel.
- 3. For safety critical applications** requiring a second set of **dual redundant signals**, the 3000 Series may be configured as two "electrical" joysticks in one mechanical package. This joystick operates on 5V and provides two outputs per axis of the same polarity for example Y, Y & X, X. The second set of outputs are accurate to the first within +/-5% of the power supply. The power supply and centre tap for the secondary outputs are also completely independent. No centre detect functionality is offered with this configuration. Customers may continue to choose their preference of voltage outputs (gains), limiter, handle or bezel.
- 4. As per option 3**, but the secondary outputs are of **inverse polarity** to the primary wipers for example X, -X & Y, -Y. The first and second outputs can be summed and compared to Centre Tap to verify that the joystick is operating correctly.
- 5. Operating on a 5V supply** the 3000 Series may be selected with a variety of **PWM output** options. For more details on the type of outputs available please refer to Apem.

Note: Configurations 3 and 4 are available as standard for one or two axes joysticks. For three axes joysticks in either configuration, please refer to Apem.

### ADDITIONAL OUTPUT INFORMATION

#### CENTRE DETECT (CD)

Where selected, (configuration 1 types) the output on this additional cable will be 0V whilst the joystick is inactive. Should either the X or Y outputs change outside of the centre tolerance, indicating that the joystick has been operated, the centre detect signal will switch to 5V. Within the joystick this output is pulled high by a 2K2 resistor and is decoupled by a 100nF capacitor to 0V. This output is designed for use in applications requiring an enable/disable signal that is separate from the main wipers. It is not recommended for use as a safety feature or a method of "person-present" detection.

#### CENTRE TAP REFERENCE (CT)

Where selected, (configurations 1, 3 and 4) the joystick also outputs a centre reference voltage that is set at 50% (+/-1%) of the supply voltage. This output can be used to check the integrity of the power supply applied to the joystick. A reading on this output, outside of the specified tolerance suggests a problem with the power supply to the joystick. The other purpose of this output is to act as a reference equal to the voltage output when the lever is at centre. Measuring the voltage outputs relative to CT rather than 0V eliminates inaccuracies created by variation in supply voltage.

#### GAIN OPTIONS

The voltage output on the wipers, at full scale deflection is determined by the gain. The gain is expressed as a percentage of the voltage supplied. Therefore (assuming a 5V supply) a joystick specified with +/- 25% gain would yield 1.25V at South, 2.5V at centre and 3.75V at North. A range of gain options are available as standard for configurations 1, 3 and 4. All joysticks are supplied pre-set and no further calibration is needed throughout the lifetime of operation.

#### OUTPUT IMPEDANCE

The voltage outputs at centre and at each end of travel are specified across an infinite load, with no current flowing. The output impedance specified in the electrical specification should be taken into account when designing a system. Load resistance of less than 10K Ohms is not recommended.

# 3000 SERIES - CONTACTLESS JOYSTICKS

## MECHANICAL INFORMATION

### MECHANISM

The omni-directional mechanism utilises an extremely robust ball-socket pivot. This construction yields an end product that is extremely resistant to vertical impact. Furthermore it constantly withstands high pull, push, rotational or horizontal forces that the product may be subject to, during life.

### SPRINGING

All 3000 Series are offered sprung to centre. The standard spring force requires 1.3N (nominally) to off-centre the joystick. The 3000 Series may be specified with a lighter spring (1N), or a stronger spring (1.6N).

### GUIDED FEEL

The 3000 Series may also be specified with guided feel. A joystick with guided feel moves more readily towards the poles (N, S, E and W) and whilst it can still move away from the poles, the force required to do so is greater. Unless specified otherwise, joysticks are supplied as standard without guiding. This standard configuration allows the user to move the joystick anywhere within the limiter with the same force and without any bias.

### CONNECTIONS

The joystick is fitted, as standard, with 150mm long, UL rated cables and an industry standard 2.5mm pitch connector(s). Further non-standard connectors and cable options are available upon request.

### CONFIGURATIONS 1 & 2

Joysticks are supplied with a seven way connector as standard. If the joystick is specified with a push button handle, the connector will be nine way.

- PIN 1:** 0V (Black)
- PIN 2:** Centre Tap Reference (Green)
- PIN 3:** Z Axis Output (Purple) - Where Specified
- PIN 4:** Y Axis Output (Yellow)
- PIN 5:** X Axis Output (Blue) - Where Specified
- PIN 6:** +V (Red)
- PIN 7:** Centre Detect (Orange)
- PIN 8:** Push Button (Orange)
- PIN 9:** Push Button (Orange)

### CONFIGURATIONS 3 & 4

Joysticks are supplied with two completely independent cable assemblies, for a truly dual system.

- PIN 1:** 0V (Black)
- PIN 2:** Centre Tap Reference (Green)
- PIN 3:** No connection
- PIN 4:** Y Axis Output (Yellow)
- PIN 5:** X Axis Output (Blue) - Where Specified
- PIN 6:** +V (Red)
- PIN 7:** No connection

For details on configuration 5 pin out, please refer to Apem.

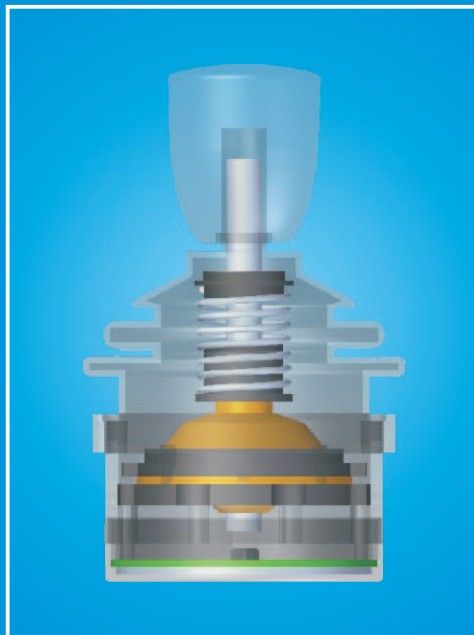
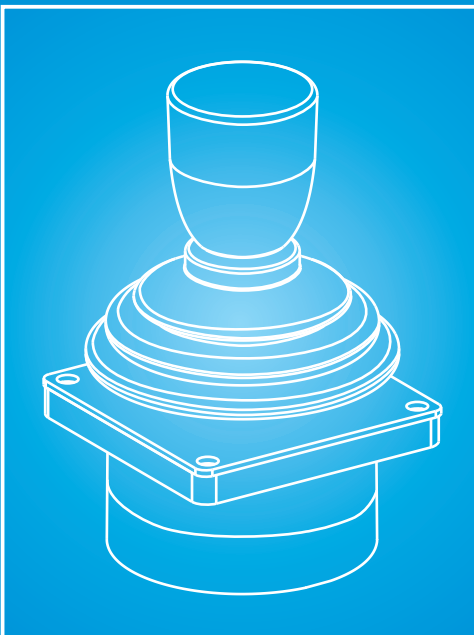



# 3000 SERIES - CONTACTLESS JOYSTICKS

## PRODUCT SPECIFICATION

### TECHNICAL SPECIFICATION

All parameters shown are based on a standard configuration and are provided for guidance only. Please refer to Apem for assistance on how to achieve the best performance from your chosen configuration.

#### ELECTRICAL

**Gain (Output Voltage Span):**  $\pm 10\% \times V$  to  $\pm 50\% \times V$

**Output at Centre:**  $V/2 \pm (5\% \times \text{Gain})$

**Power Supply:** 5V  $\pm 0.5V$  Transient free (Configs 1, 3, 4 & 5) or 3.3V  $\pm 0.1V$  (Config 2)

**Centre Tap Impedance:** 1K $\Omega$

**Centre Detect Output:** Pulled high within joystick via 2K $\Omega$  to +V, and smoothed to 0V with 100nF

**Sensor Type:** Hall effect

**Current Consumption:** <13mA (Two axes) - <20mA (Three axes)

**Loads:** Minimum 10K $\Omega$ , preferred 100K $\Omega$ +

#### ENVIRONMENTAL

**Storage :** -40C to +70C

**Operating Temperature:** -25C to +70C

**Seal Above Panel:** IP 65 - Neoprene gaiter (boot) fitted as standard

**EMC Emissions:** Complies with EN 61000-6-3:2001 CISPR 22:2005 Class B 30MHz - 1GHz

**Life Cycles:** 10,000,000 cycles (5,000,000 for 3 axes joysticks)

**ESD:** Complies with EN61000-4-2 (extended) + -8KV (20 contacts) & + -15KV (20 air discharges)

**EMC Immunity:** 100V/m, 80MHz-2.7GHz, 1KHz 80% sine wave modulation, EN 61000-4-3 (extended)

**Vibration:** 100Hz - 200Hz @ 0.13g<sup>2</sup>/Hz, total 3.6gRMS (1 Hour in each of the three mutually perpendicular axes)

#### MECHANICAL

**Materials Employed :** Shaft - Stainless Steel, Gaiter (Boot) - Neoprene, Others - Brass, Nylon, ABS

**Weight:** 100g

**Mechanical Operating Angle:** X and Y Axes  $\pm 18$  Degrees (subject to choice of limiter). Z Axis  $\pm 25$  Degrees

**Max Load to Mechanism:** 400N

# 3000 SERIES - CONTACTLESS JOYSTICKS

## PRODUCT OPTIONS

### STANDARD OPTION SELECTION

To specify your 3000 Series joystick, simply choose one option from each column. An example is shown below.

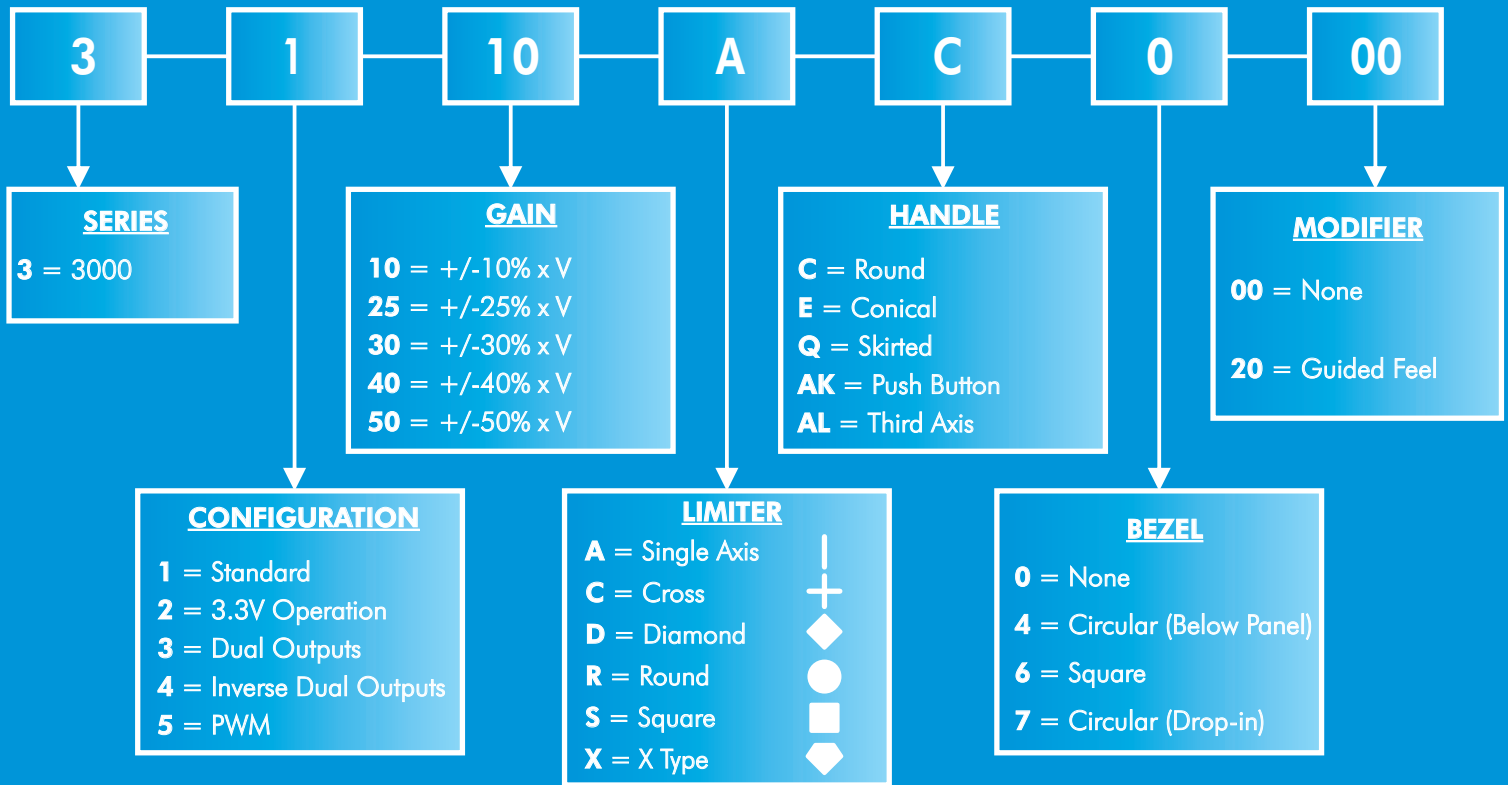

### STANDARD OPTION AVAILABILITY

The following table shows which permutations of options are possible.

Configuration	CT	CD	AXES			SUPPLY		GAIN					LIMITERS					ALL HANDLES	ALL BEZELS			
			X	Y	Z	3.3	5V	10	25	30	40	50	A	C	D	R	S			X		
1	✓	✓	✓	✓	✓	✗	✓	✓	✓	✓	✓	✗	✓	✓	✓	✓	✓	✓	✓	✓	✓	✓
2	✗	✗	✓	✓	✓	✓	✗	✗	✗	✗	✗	✓	✓	✓	✓	✓	✓	✓	✓	✓	✓	✓
3	✗	✗	✓	✓	✗	✗	✓	✓	✓	✓	✓	✗	✓	✓	✓	✓	✓	✓	✓	✓	✓	✓
4	✗	✗	✓	✓	✗	✗	✓	✓	✓	✓	✓	✗	✓	✓	✓	✓	✓	✓	✓	✓	✓	✓
5	✗	✗	✓	✓	✓	✗	✓	✗	✗	✗	✗	✗	✓	✓	✓	✓	✓	✓	✓	✓	✓	✓

### HANDLE AND BEZEL OPTIONS

For drop in mounting, please specify bezel option 6 or 7. For sub-panel mounting, no bezel is necessary, unless the gaiter is required to seal to the face of the panel in which case bezel option 4 should be specified. Further mounting information including panel cutouts are shown on the following pages. A small selection of the available handles are shown above. For the full Apem handle range please refer to our separate handle guide datasheet.

# 3000 SERIES - CONTACTLESS JOYSTICKS

## USEFUL DIMENSIONS

### GENERAL DIMENSIONS

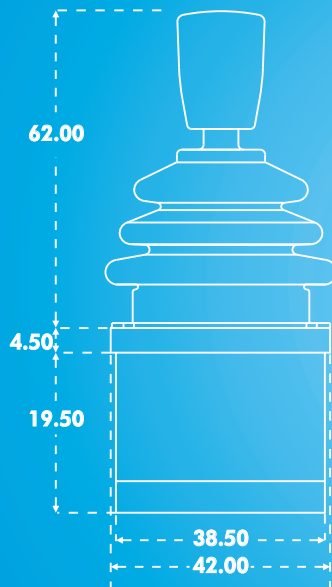

### PRIMARY OUTPUT POLARITY



LEADS EXIT TO THE EAST  
VIEWED FROM ABOVE

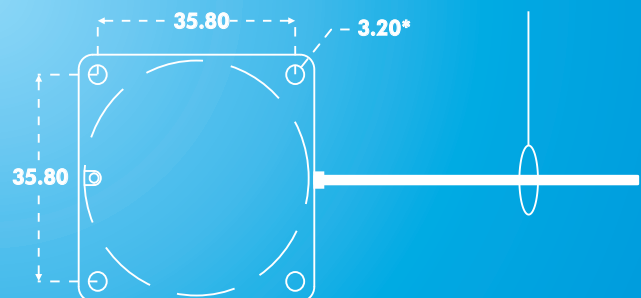

### DROP IN MOUNTING - PANEL CUT-OUT & MOUNTING INSTALLATION

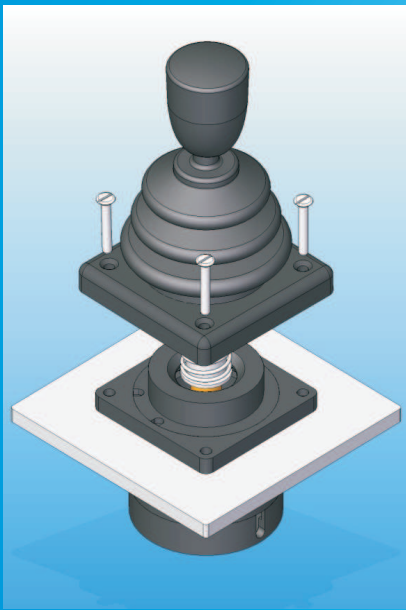

### MOUNTING CUT-OUT

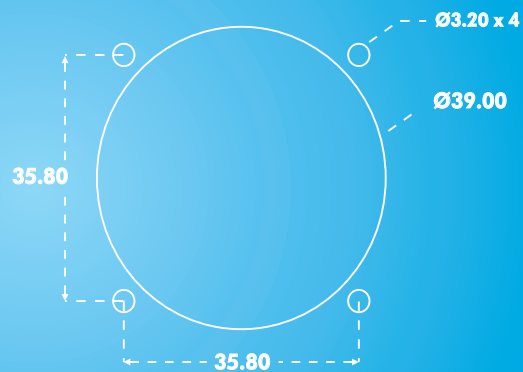

The joystick is dropped into the panel cut-out. For panel thickness of <math>< 3\text{mm}</math>, M3 x 16 countersunk machine screws are recommended. Illustration (left) shows the square bezel option, a circular bezel is also available.  
Please note: Image (left) shows a square bezel, a circular bezel is also available for this option.

Note: The dimensions shown are for a generic 3000 Series with the E type handle. For specific dimensions of this or any other configuration please refer to Apem.

\* 3000 Series has slotted mounting holes - allows compatibility with mounting pitches 32.25mm to 35.80mm

# 3000 SERIES - CONTACTLESS JOYSTICKS

## MOUNTING INSTALLATIONS

### MOUNTING OPTION A - PANEL CUT-OUT & MOUNTING INSTALLATION

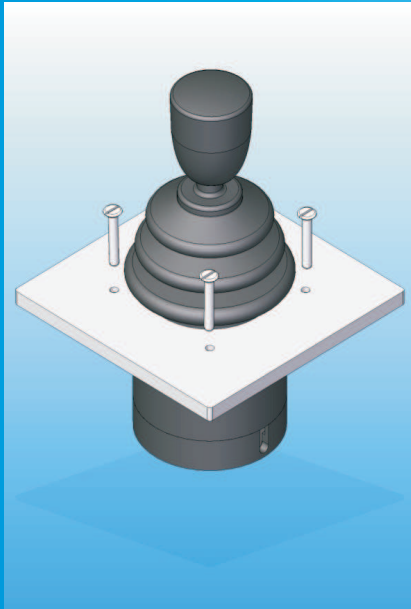

#### MOUNTING CUT-OUT

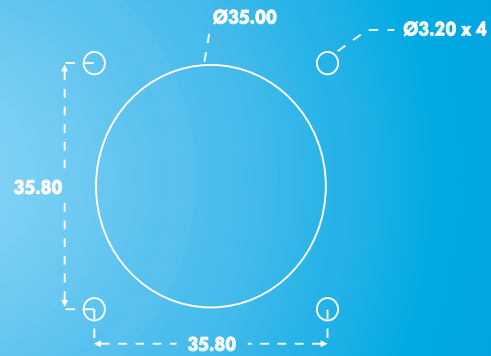

When mounted this way the panel acts as the bezel and no separate bezel is needed. M3 machine screws are recommended.

### MOUNTING OPTION B - PANEL CUT-OUT & MOUNTING INSTALLATION

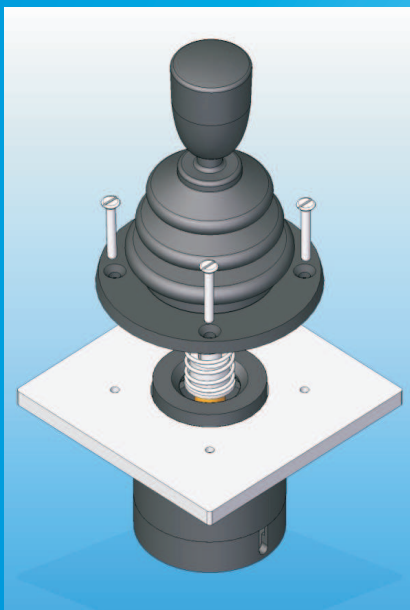

#### MOUNTING CUT-OUT

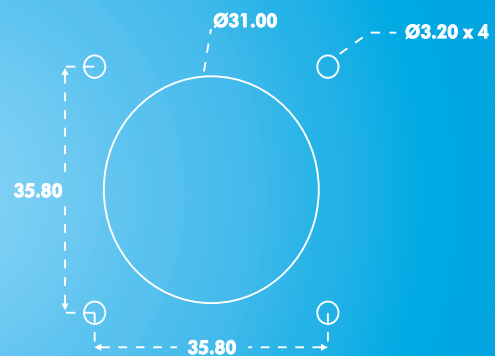

The joystick flange is mounted beneath the panel and the base of the gaiter must be brought through the panel cut-out and held in place with the circular bezel. For panel thicknesses of  $< 3\text{mm}$ , M3 x 16 countersunk machine screws are recommended.

**Note:** When sub-panel mounting, great care should be taken not to damage the gaiter, or any of the mechanism under the gaiter. All panel cut-outs should be free from sharp edges and debris that may damage the gaiter.





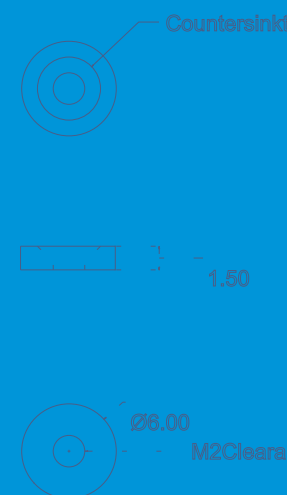
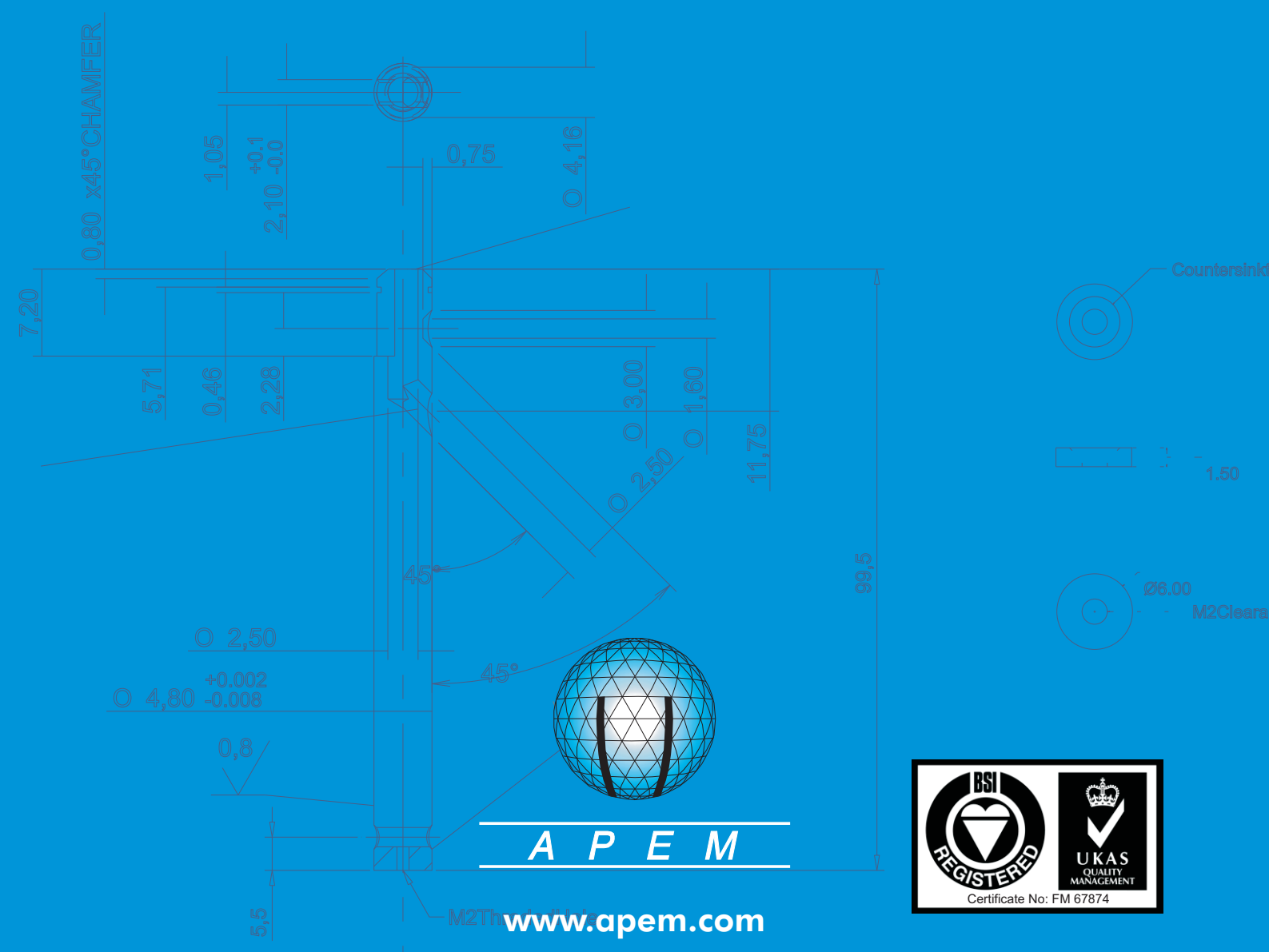
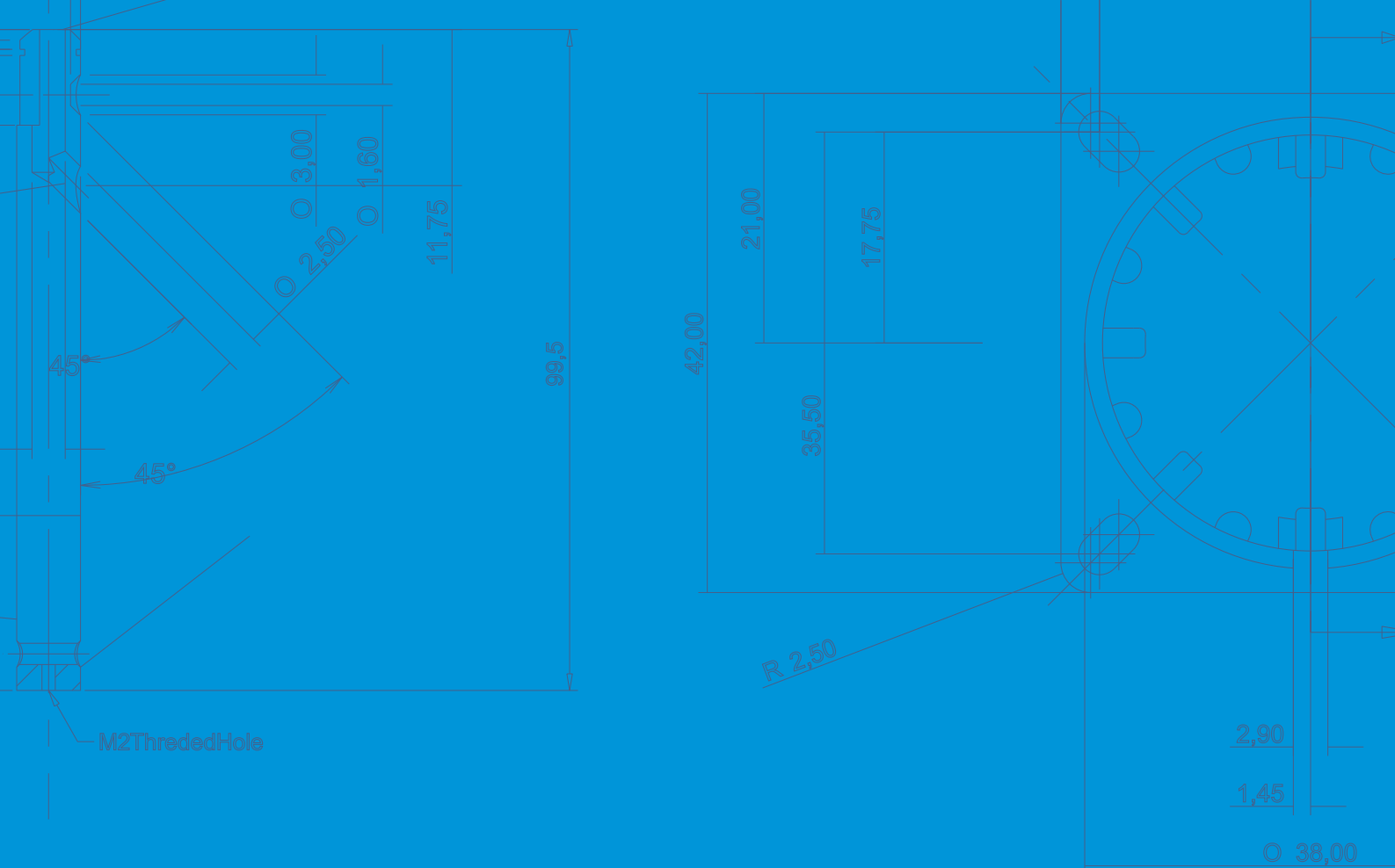

**A P E M**

[www.apem.com](http://www.apem.com)

