

Data sheet

Article Description

Foot Intermediate Serial Switch Type 8009

2 (1) A, 250 V, 1-pole, **serial switch**,
catch locking housing, screwed strain relief,
2 connecting terminals, screw terminals,
for cable 2 x 0.75 mm² + 3 x 0.75 mm²,
serial connection 0/1/1+2/2/0
dimensions: Ø 66 mm / height 35 mm (with button)

Article Picture

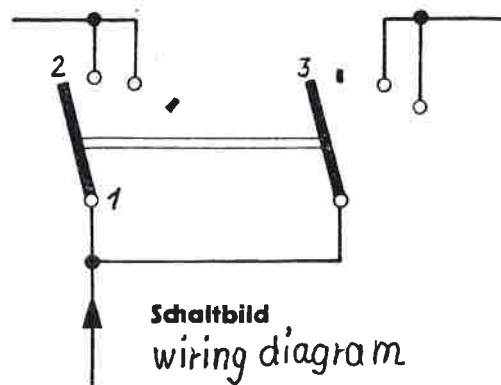
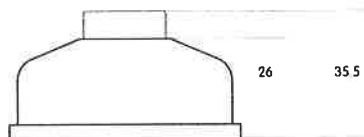
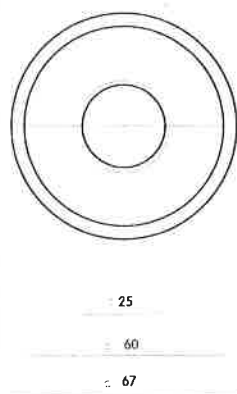

<i>inter BÄR-No.</i>	<i>colour housing/button</i>
8009-011...	white/black
8009-012..	black/black
8009-013...	gold/gold

Technical modifications reserved!
Works at 230 V-mains must only be carried out by a specialist!