

# FOOT SWITCHES

PRODUCT NUMBER 2410.0301



## TECHNICAL DATA

<b>Product number</b>	<b>2410.0301</b>
Actuator color / printing	
Product family	Foot switches
Actuation type	direct
Weight	305.842 g
ROHS conform	yes
Switching function	Normally open contact (SPNO)
Material fixed contact	Ag
Number of poles	1 - pole
connections	Socket terminal, 2 terminals, M3
Mechanical life endurance	30E4
Rating IEC	6 (2.5) A 250 V AC 5E4
Proof tracking	250 PTI
Insulation spacing	acc. to EN 61058 for reinforced or double insulation
Actuators and additional actuators	foot plate: PA, black, similar RAL 7024
Housing description	housing: PA, black, 4 rubber feet, opening for hanging up
Contact material	Ag
Contact distance	< 3 mm
Contact type	friction jump contact
Operating force	31 ±5 N
Approval marks	ENEC 10
Miscellaneous	with switch 1005.1801
Degree of pollution	3
Type of connection	1.2 Single pole, single load (single-pole disconnection)
Stock version	●

## PRODUCT IMAGE



## DRAWINGS

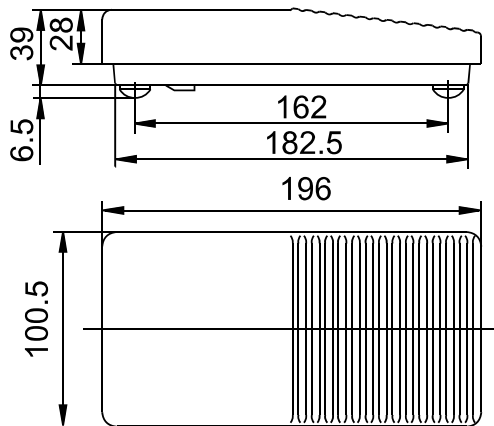

Technical changes reserved. Dimensions are not binding.  
Detailed specifications available on request.

---

Marquardt GmbH · Schloss-Straße 16 · 78604 Rietheim-Weilheim · Germany  
Phone: +49 (0) 7424 / 99-0 · Fax: +49 (0) 7424 / 99-2399 · [www.marquardt.com](http://www.marquardt.com) · [marquardt@marquardt.de](mailto:marquardt@marquardt.de)