

Reversing load relay - ELR W1/ 2-24DC - 2963598

Please be informed that the data shown in this PDF Document is generated from our Online Catalog. Please find the complete data in the user's documentation. Our General Terms of Use for Downloads are valid (<http://download.phoenixcontact.com>)



Electronic reversing load relay, for driving DC motors, with light indicator and protection circuit, output: 10-30 V DC/2 A

Illustration shows item ELR W1/ 6-24DC



Key commercial data

package_quantity	1
GTIN	4017918943592

Technical data

Note:

Utilization restriction	EMC: class A product, see manufacturer's declaration in the download area
-------------------------	---

Dimensions

Width	12.5 mm
Height	99 mm
Depth	114.5 mm

Ambient conditions

Ambient temperature (operation)	-20 °C ... 60 °C
Ambient temperature (storage/transport)	-20 °C ... 70 °C
Degree of protection	IP20

Input data

Input name	Device supply
Protective circuit	Protection against polarity reversal Polarity protection diode
Protective circuit	Surge protection
Operating voltage display	Green LED
Status display	LED yellow, forward running (R), LED yellow, reverse running (L)
Input name	Control input right/left
Nominal input voltage U_N	24 V DC
Input voltage range in reference to U_N	0.8 ... 1.2
Typical input current at U_N	3 mA

Reversing load relay - ELR W1/ 2-24DC - 2963598

Technical data

Input data

Protective circuit	Protection against polarity reversal
Protective circuit	Surge protection
Surge voltage protection	> 33 V DC
Typical response time	200 µs
Status display	LED yellow, forward running (R), LED yellow, reverse running (L)
Current consumption	3 mA
Switchover time R_L/L_L (turn-on time)	80 ms

Output data

Output name	DC output
Nominal output voltage range	10 V DC ... 30 V DC
Load current	2 A (Mounted in rows with zero spacing)
Quiescent current	approx. 7 mA (When switched off)
Type of protection	Protection against polarity reversal
Type of protection	Surge protection
Surge voltage protection	> 33 V DC
Operating voltage display	Green LED
Current limitation at short-circuits	15 A

Connection data

Connection method	Screw connection
Stripping length	8 mm
Conductor cross section solid min.	0.2 mm ²
Conductor cross section solid max.	6 mm ²
Conductor cross section stranded min.	0.2 mm ²
Conductor cross section stranded max.	4 mm ²
Conductor cross section AWG/kcmil min.	24
Conductor cross section AWG/kcmil max	10
Screw thread	M3

General

Test voltage input/output	2.5 kV AC
Mounting position	Vertical (horizontal DIN rail)
Assembly instructions	Any
Operating mode	100% operating factor
Name	Air and creepage distances between the power circuits
Standards/regulations	EN 50178
Standards/regulations	Basic insulation
Pollution degree	2
Surge voltage category	III

Reversing load relay - ELR W1/ 2-24DC - 2963598

classifications

eCl@ss

eCl@ss 4.0	27371102
eCl@ss 4.1	27371102
eCl@ss 5.0	27371601
eCl@ss 5.1	27371601
eCl@ss 6.0	27371601
eCl@ss 7.0	27371601
eCl@ss 8.0	27371601

ETIM

ETIM 2.0	EC000066
ETIM 3.0	EC000066
ETIM 4.0	EC000066
ETIM 5.0	EC002055

UNSPSC

UNSPSC 6.01	30211915
UNSPSC 7.0901	39121514
UNSPSC 11	39121514
UNSPSC 12.01	39121514
UNSPSC 13.2	39121514

approvals

UL Listed / cUL Listed / UL Listed / cUL Listed / cULus Listed /

Approval details

UL Listed

cUL Listed

Reversing load relay - ELR W1/ 2-24DC - 2963598

approvals



Drawings

Connection diagram

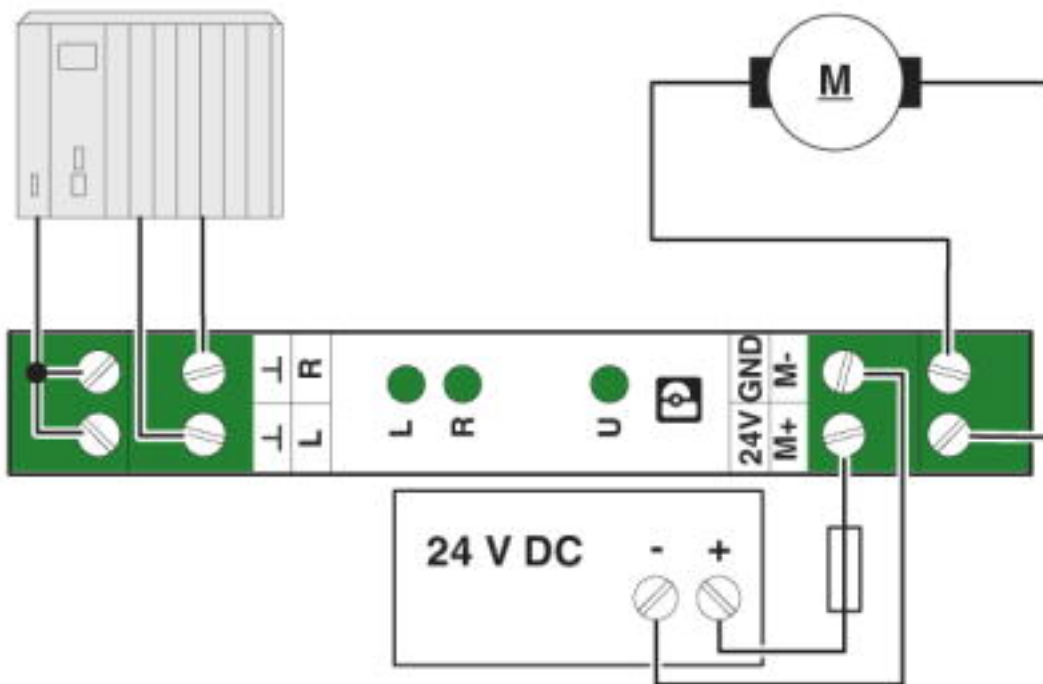

Reversing load relay - ELR W1/ 2-24DC - 2963598

Application drawing

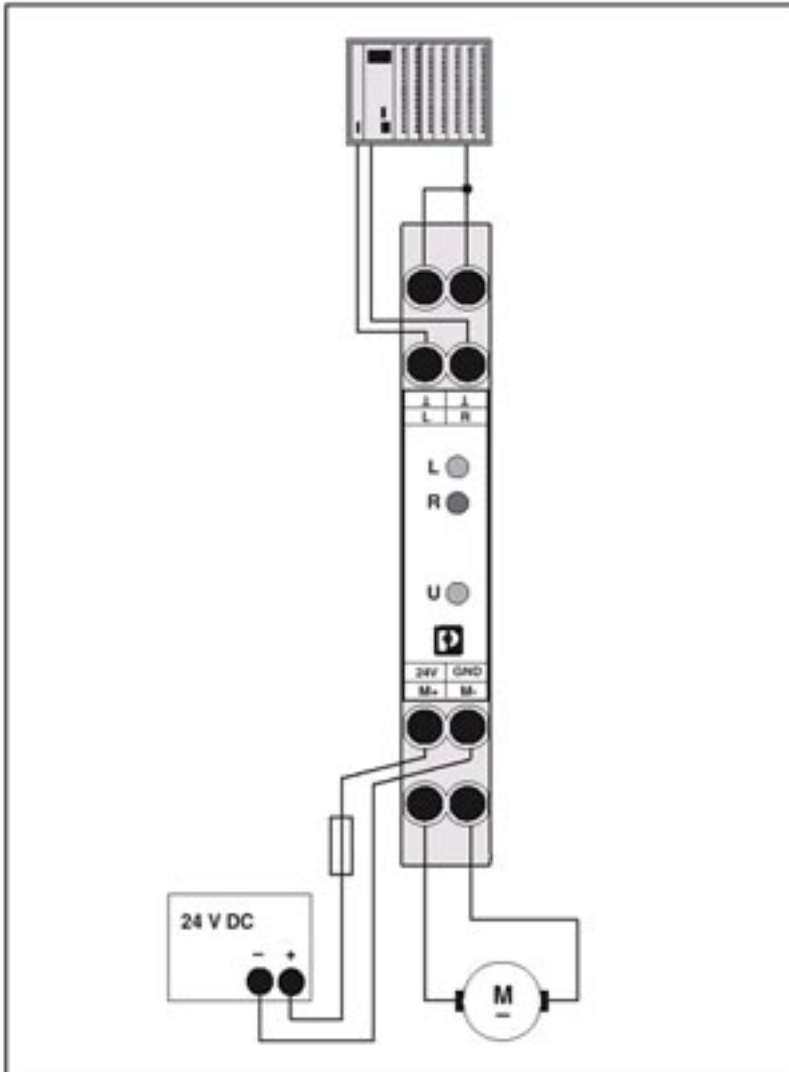

Example application

Reversing load relay - ELR W1/ 2-24DC - 2963598

Block diagram

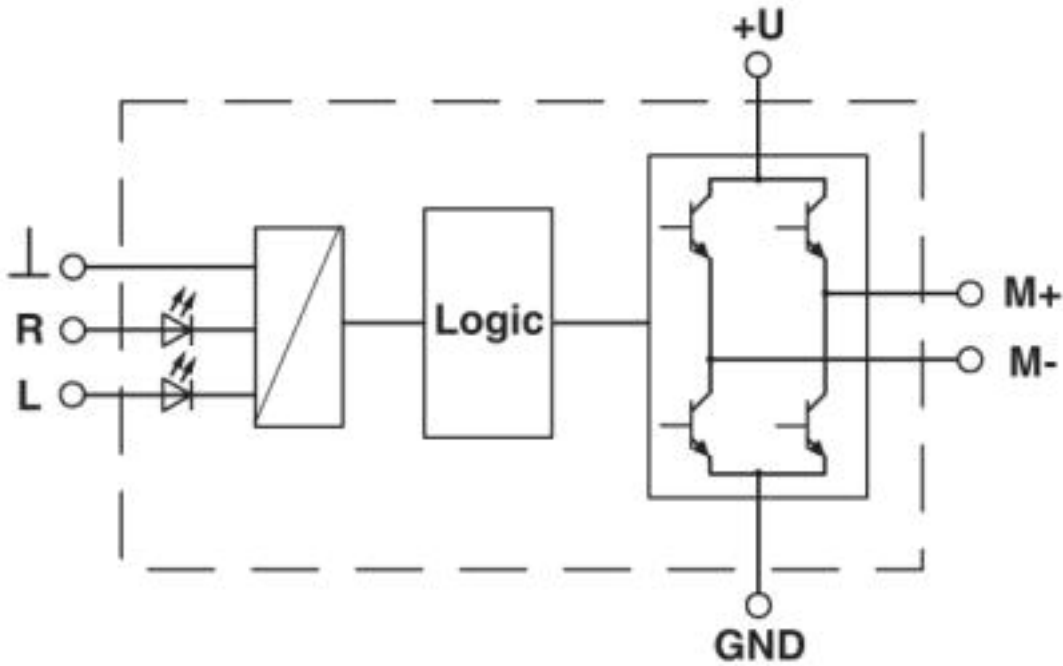

Diagram

