

FULLY OPEN

CLOSED

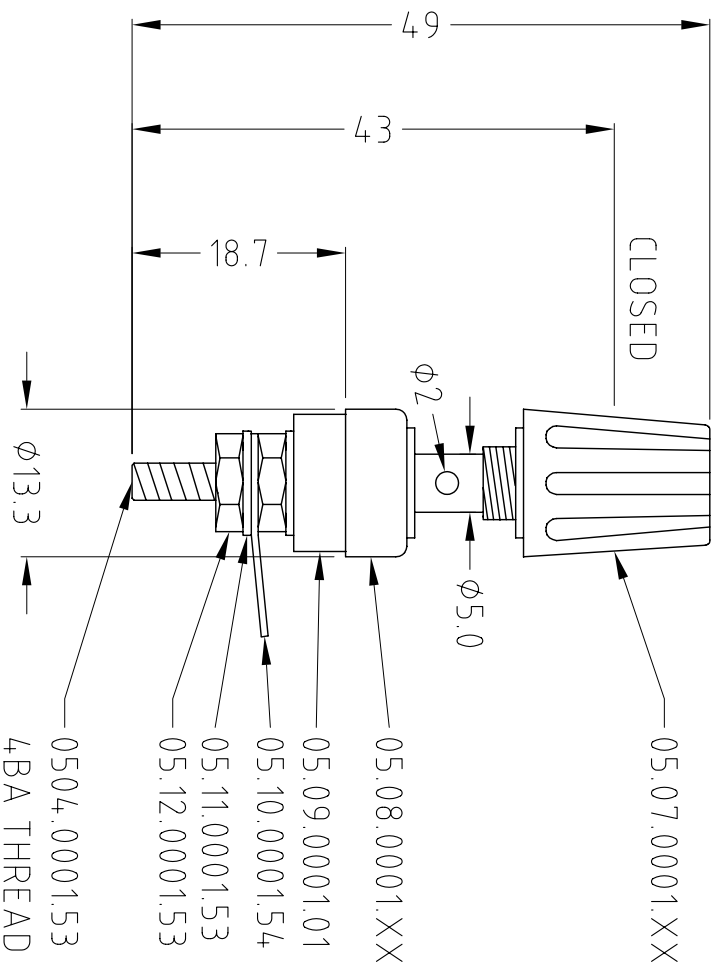

MOUNTING HOLE

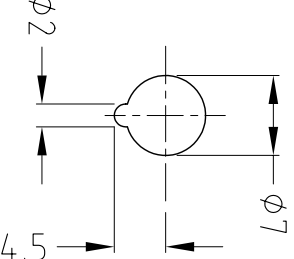

P/No.	VARIANTS		COLOURS		
	MODEL	MODEL	Knob	TOP INS	BOT INS
CL1505	TP/1 BLACK	TP/1 BLACK	BLACK	BLACK	CLEAR
CL1505U	TP/1 BLACK UNASS	TP/1 BLACK UNASS	BLACK	BLACK	CLEAR
CL1506	TP/1 RED	TP/1 RED	RED	RED	CLEAR
CL1506U	TP/1 RED UNASS	TP/1 RED UNASS	RED	RED	CLEAR
CL1507	TP/1 BLUE	TP/1 BLUE	BLUE	BLUE	CLEAR
CL1507U	TP/1 BLUE UNASS	TP/1 BLUE UNASS	BLUE	BLUE	CLEAR
CL1508	TP/1 GREEN	TP/1 GREEN	GREEN	GREEN	CLEAR
CL1508U	TP/1 GREEN UNASS	TP/1 GREEN UNASS	GREEN	GREEN	CLEAR
CL1509	TP/1 WHITE	TP/1 WHITE	WHITE	WHITE	CLEAR
CL1509U	TP/1 WHITE UNASS	TP/1 WHITE UNASS	WHITE	WHITE	CLEAR
CL1511	TP/1 BROWN	TP/1 BROWN	BROWN	BROWN	CLEAR
CL1511U	TP/1 BROWN UNASS	TP/1 BROWN UNASS	BROWN	BROWN	CLEAR
CL1512	TP/1 YELLOW	TP/1 YELLOW	YELLOW	YELLOW	CLEAR
CL1512U	TP/1 YELLOW UNASS	TP/1 YELLOW UNASS	YELLOW	YELLOW	CLEAR

ASSEMBLY NOTES:

- 1) SUPPLIED ASSEMBLED AS SHOWN IS STANDARD.
- 2) 'U' VARIANTS ARE SUPPLIED UNASSEMBLED.
TOP + BOT INSULATORS, NUTS, WASHERS, BULK PACKED.



TOLERANCE
 NO DEC. PLACE ±
 1 DEC. PLACE ±
 2 DEC. PLACE ±
 HOLE Ø ±
 ANGLES ±
 UNLESS
 OTHERWISE STATED

Cliff Electronic Components Ltd.

76 Holmechrop Avenue, Holmechrop Industrial Estate,
 Redhill, Surrey, RH1 2PF, England, UK
 Tel: 01737-771375 Fax: 01737-766012 Website: www.cliffuk.co.uk
 THE CONTENTS OF THIS DOCUMENT MUST NOT BE COPIED OR DISCLOSED
 TO A 3rd PARTY WITHOUT WRITTEN PERMISSION OF CLIFF UK. © 2009

MATERIAL:	POLYPROP / BRASS / POLYAMIDE
FINISH:	AS MOULDED / Ag / NI PLATED
DRAWN:	C.A.M.J.

TITLE:	TERMINAL POST TP/1
3rd ANGLE PROJECTION:	
DO NOT SCALE	
FORM:	ADDRWGH

ISS.	AMEND	DATE
1	1st DRAWN	23/06/09
2	UNASSEM VAR ADD	13/05/11
3	VAR UNASSEM ADD	21/09/12