



46.02mm Dia 15 Turn Dial



FEATURES

- Round Vernier Scale
- 1-13/16" Dia.
- 1/4" or 1/8" Shaft Adapter
- Satin Chrome Finish with Black Markings
- Black Chrome Finish with White Markings
- Brushed Chrome Finish with Black Markings

MECHANICAL SPECIFICATIONS	
PARAMETER	
Mounting	Direct to shaft with # 4 - 40 hex socket set screw located adjacent to No.75 on graduated dial.
Numeral Size: Counter wheel: Graduated dial:	0.90 H x 0.013 Inches W (2.29 x 0.33cm) 0.109 x 0.018 Inches (2.77 x 0.46cm)
Graduation Size: Numeral and every Fifth	0.55 Inches L (1.40cm)
Intermediate	0.035 Inches L (0.89cm)
Width	0.012 Inches (0.30cm)
Weight	3.0 maximum (85.05)

OPERATIONAL SPECIFICATIONS	
Readout and Operation	1499 turns total The number in window (0 thru 14) indicates completed number of turns of the drive sleeve. Graduated circular dial indicates the percent of the partial turn of the drive sleeve
Transfer Point	The number in center of window shall change as graduated dial rotates between 94 and 0
Rotation	Readout shall increase with clockwise and decrease with counterclockwise rotation
Accuracy	Zero backlash between graduated dial and drive sleeve

DIMENSIONS in inches (millimeters)

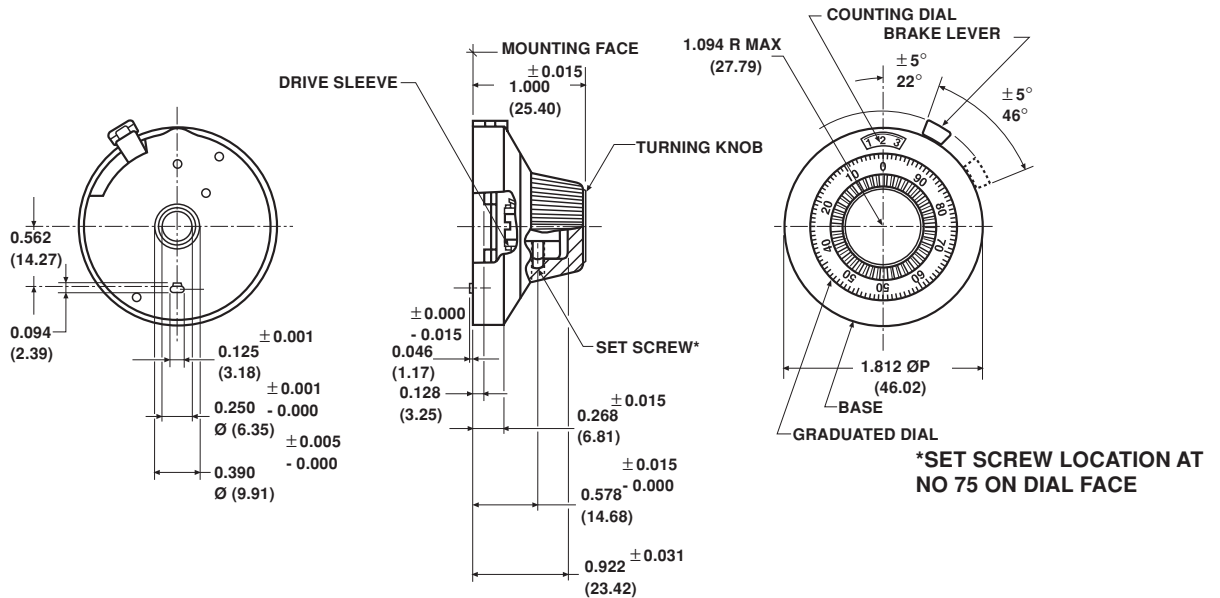

ORDERING INFORMATION		
21 MODEL	1 SHAFT DIAMETER AND ACCOMMODATION	11 FINISH AND OTHER FEATURES
Example: 21 - 1 - 11	1. 1/4" Shaft (standard) 3. 1/8" Shaft adapter	11. Satin chrome, black markings 21. Black chrome, white markings 31. Brushed chrome, black markings