

# Sonpak LX 15/25/40

96231765 SONPAK LX 150W 230V HST/E40/220 A/S

E40	 HST	150W HST	T <sub>a</sub> 25	IP65	IK06		
-----	---	----------	-------------------	------	------	---	---

A new range of easy to install performance floodlights supplied complete with lamp.

A redesigned robust and compact discharge floodlight with IP65 optical and gear compartment, SC1 class. black die-cast aluminium body with vandal resistant Flat Glass enclosure.

mild steel painted black stirrup.

Sonpak LX 15/25/40 uses aluminium - texturebrite asymmetrical reflector and is supplied complete with integral control gear and 150 W HST lamp.

Dimensions: 522 x 426 x 130 mm

Weight: 8 kg.



TLG\_SPK7\_F\_LX15.jpg

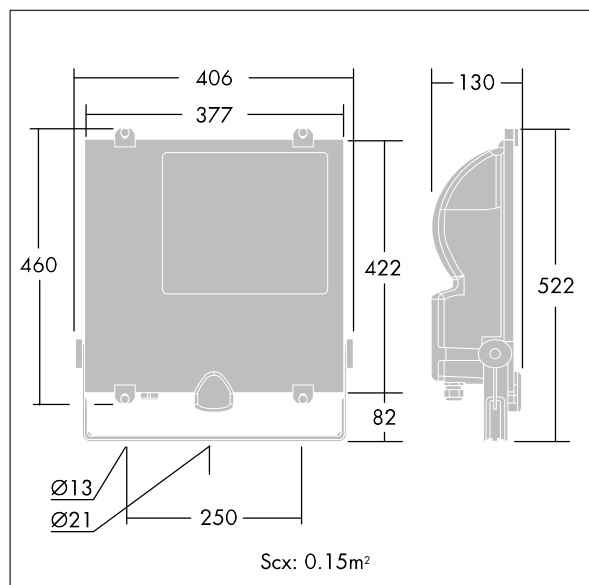

TLG\_SPK7\_M\_LXLD15.wmf

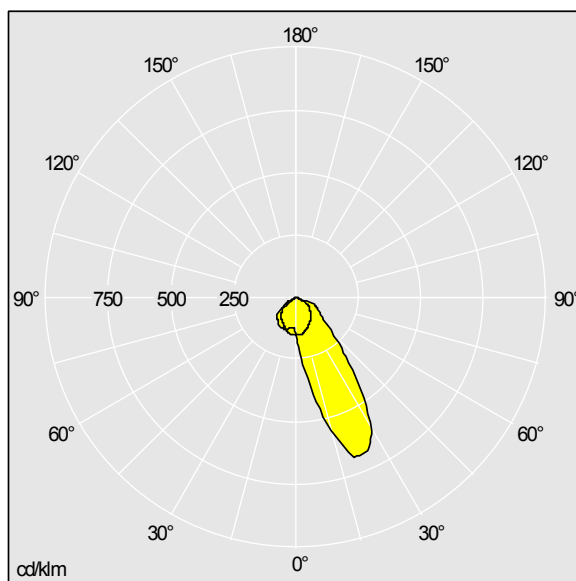

TLG\_LA\_SE00007.ltd

Lamp position:STD - standard

Lamps:1 x HST / 150W

Total luminous flux:15000 lm

Luminaire efficacy:62 lm/W

Colour Rendering Index min.:20

Ballast:MAG

Connected Load:171 W

LOR: 0,70 ULOR: 0,00 DLOR: 0,70