

Housing - HC-B 24-TMB-100/O1STM40G-STA - 1604599

Please be informed that the data shown in this PDF Document is generated from our Online Catalog. Please find the complete data in the user's documentation. Our General Terms of Use for Downloads are valid (<http://download.phoenixcontact.com>)



HEAVYCON ADVANCE standard powder-coated sleeve housing B24, with bayonet locking, height 100 mm, with 1x M40 thread, straight cable outlet

The illustration shows the version HC-B 24-TMB-100/O1STM32S-STA

Key commercial data

package_quantity	10
GTIN	4017918948276

Technical data

Dimensions

Height	100 mm
Width	57 mm
Length	152 mm
Length of the assembly cutout	112 mm
Width of the assembly cutout	35 mm

Ambient conditions

Degree of protection for housing	IP65
Degree of protection for housing	IP67
Ambient temperature (operation)	-40 °C ... 125 °C

General

Note	For contact inserts HC-B24, BB46, D64, DD108, HV10/16, M
Design	B24
Housing type	Sleeve housings
Locking type	Bayonet locking
No. of cable exits	1
Cable exit	Straight
Screw connection	None
Type of the screw connection	1x M40
Housing material	Aluminum die-cast
Housing surface material	Powder-coated, gray
Seal material	NBR
Material lock	High-grade steel

Housing - HC-B 24-TMB-100/O1STM40G-STA - 1604599

Technical data

General

Material grip body interlock	PA-GF
Assembly instructions	In order to guarantee that the ground conductor contact functions even when plugged in at an angle, the two panel mounting flanges must have sufficient electrical contact with the metal mounting panel.

classifications

eCl@ss

eCl@ss 4.0	272607xx
eCl@ss 4.1	27260701
eCl@ss 5.0	27143424
eCl@ss 5.1	27143424
eCl@ss 6.0	27371205
eCl@ss 7.0	27371205
eCl@ss 8.0	27371205

ETIM

ETIM 2.0	EC000437
ETIM 3.0	EC000437
ETIM 4.0	EC000437
ETIM 5.0	EC000437

UNSPSC

UNSPSC 6.01	31261502
UNSPSC 7.0901	31261502
UNSPSC 11	31261502
UNSPSC 12.01	31261502
UNSPSC 13.2	31261502

accessories

Panel mounting flange

HC-B-BF - 1604641



Housing - HC-B 24-TMB-100/O1STM40G-STA - 1604599

accessories

HC-B-BF-SET - 1604654



Protective cover

HC-B 24-TMB-SD-IP65 - 1690969



Full screw connection

HC-K-KV-M40(19-28) - 1690655



HC-M-KV-M40(19-27) - 1690590



HC-M-KV-M40(27-34) - 1607729



Drawings

Housing - HC-B 24-TMB-100/O1STM40G-STA - 1604599

Dimensioned drawing

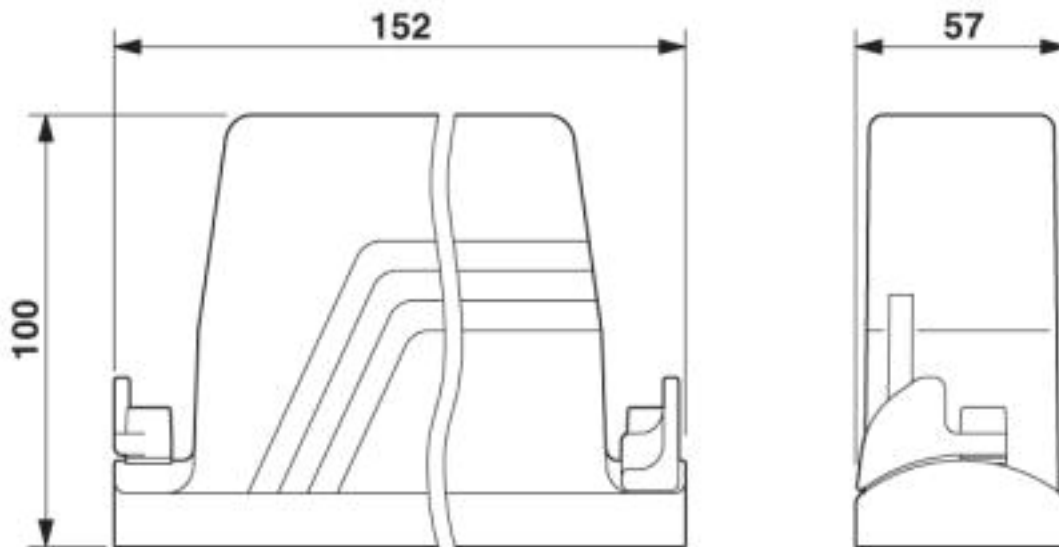

Dimensioned drawing

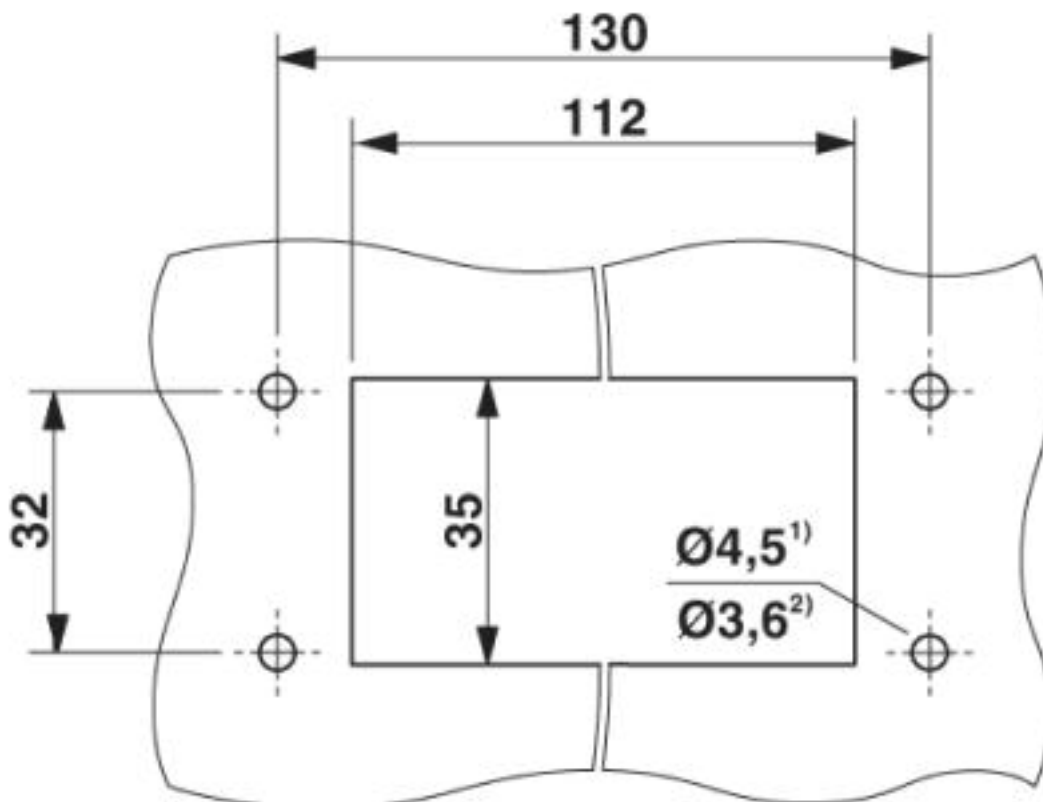

Panel cutout²⁾ When self-tapping screws are used (Torx® 20, M4)

